

APPLICATION NOTE

AN192

A complete FM radio on a chip

Authors: W.H.A. Van Dooremolen and M. Hufschmidt

1991 Dec

A complete FM radio on a chip

AN192

Authors: *W.H.A. Van Dooremolen, M. Hufschmidt*

Until now, the almost total integration of an FM radio has been prevented by the need for LC tuned circuits in the RF, IF, local oscillator and demodulator stages. An obvious way to eliminate the coils in the IF and demodulator stages is to reduce the normally used intermediate frequency of 10.7MHz to a frequency that can be tuned by active RC filters, the op amps and resistors of which can be integrated. An IF of zero deems to be ideal because it eliminates spurious signals such as repeat spots and image response, but it would not allow the IF signal to be limited prior to demodulation, resulting in poor signal-to-noise ratio and no AM suppression. With an IF of 70kHz, these problems are overcome and the image frequency occurs about halfway between the desired signal and the center of the adjacent channel. However, the IF image signal must be suppressed and, in common with conventional FM radios, there is also a need to suppress interstation noise and noise when tuned to a weak signal. Spurious responses above and below the center frequency of the desired station (side tunings), and harmonic distortion in the event of very inaccurate tuning must also be eliminated.

We have now developed a mono FM reception system which is suitable for almost total integration. It uses an active 70kHz IF filter and a unique correlation muting circuit for suppressing spurious signals such as side responses caused by the flanks of the demodulator S-curve. With such a low IF, distortion would occur with the $\pm 75\text{kHz}$ IF swing due to received signals with maximum modulation. The maximum IF swing is therefore compressed to $\pm 15\text{kHz}$ by controlling the local oscillator in a frequency-locked loop (FLL). The combined action of the muting circuit and the FLL also suppresses image response.

The new circuit is the TDA7000 which integrates a mono FM radio all the way from the aerial input to the audio output. External to the IC are only one tunable LC circuit for the local oscillator, a few inexpensive ceramic plate capacitors and one resistor. The TDA7000 dramatically reduces assembly and post-production alignment costs because only the oscillator circuit needs adjustment during manufacture to set the limits of the tuned frequency band. The complete FM radio can be made small enough to fit inside a calculator, cigarette lighter, key-ring fob or even a slim watch. The TDA7000 can also be used as receiver in equipment such as cordless telephones, CB radios, radio-controlled models, paging systems, the sound channel of a TV set or other FM demodulating systems.

Using the TDA7000 results in significant improvements for all classes of FM radio. For simpler portables, the small size, lack of IF coils, easy assembly and low power consumption are not the only attractive features. The unique correlation muting system and the FLL make it very easy to tune, even when using a tiny tuning knob. For higher-performance portables and clock radios, variable-capacitance diode tuning and station presetting facilities are often required. These are easily provided with the TDA7000 because there are no variable tuned circuits in the RF signal path. Only the local oscillator needs to be tuned, so tracking and distortion problems are eliminated.

The TDA7000 is available in either an 18-lead plastic DIP package (TDA7000), or in a 16-pin SO package (TDA7010T). Future developments will include reducing the present supply voltage (4.5V typ.), and the introduction of FM stereo and AM/FM versions.

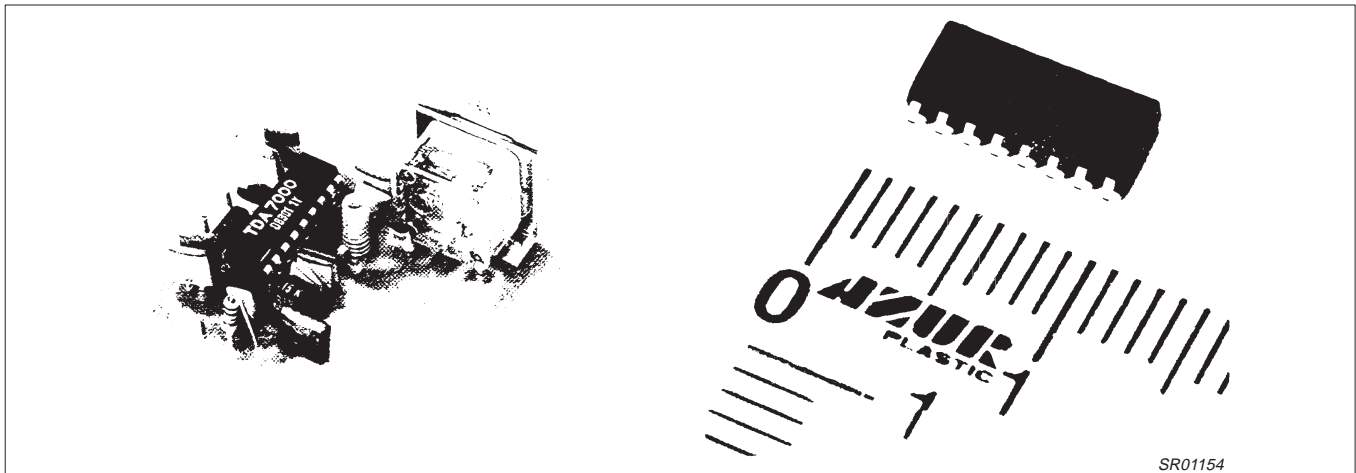

Figure 1. A Laboratory Model of the TDA7000 in a Complete FM Radio. Also Shown is the TDA7010T in the SO Package Against a CM Scale.

BRIEF DATA

SYMBOL	DESCRIPTION	MIN	TYP	MAX	UNITS
V_{CC}	Typical supply voltage		4.5		V
I_{CC}	Typical supply current		8		mA
f_{RF}	RF input frequency range	1.5		110	MHz
V_{RF-3dB}	Sensitivity for -3dB limiting EMF with $Z_S = 75\Omega$, mute disabled		1.5		μV
V_{RF}	Maximum signal input for THD < 10%, $\Delta f = \pm 75\text{kHz}$ EMF with $Z_S = 75\Omega$		200		mV
V_O	Audio output (RMS) with $R_L = 22\text{k}\Omega$, $\Delta f = \pm 22.5\text{kHz}$		75		mV

A complete FM radio on a chip

AN192

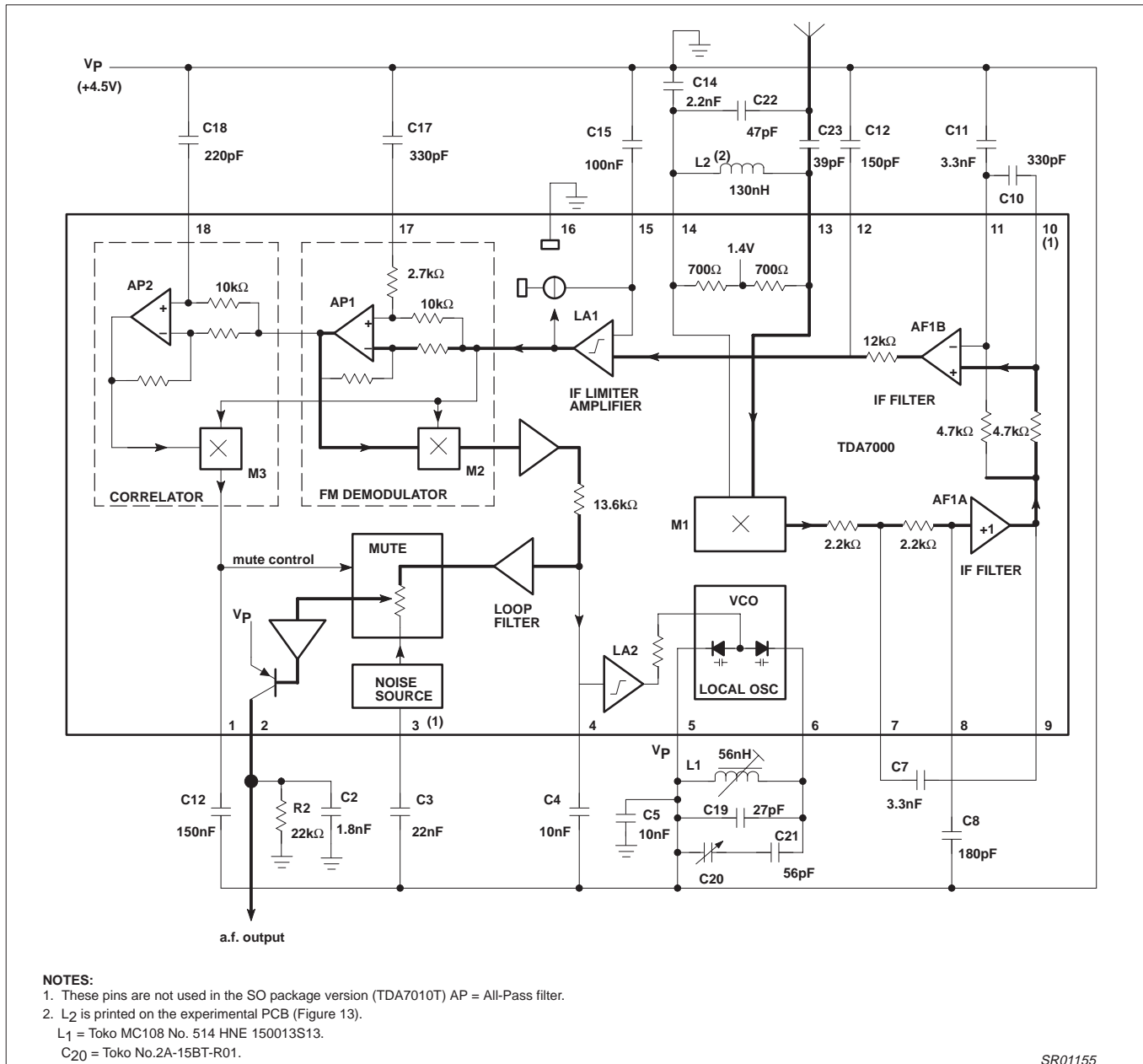

Figure 2. The TDA7000 as a Variable Capacitor-Tuned FM Broadcast Receiver

CIRCUIT DESCRIPTION

As shown in Figure 2, the TDA7000 consists of a local oscillator and a mixer, a two-stage active IF filter followed by an IF limiter/amplifier, a quadrature FM demodulator, and an audio muting circuit controlled by an IF waveform correlator. The conversion gain of the mixer, together with the high gain of the IF limiter/amplifier, provides AVC action and effective suppression of AM signals. The RF input to the TDA7000 for -3dB limiting is 1.5µV. In a conventional portable radio, limiting at such a low RF input level would cause instability because higher harmonics of the clipped IF signal would be radiated to the aerial. With the low IF used with the TDA7000, the radiation is negligible.

To prevent distortion with the low IF used with the TDA7000, it is necessary to restrict the IF deviation due to heavily modulated RF signals to ±15kHz. This is achieved with a frequency-locked loop (FLL) in which the output from the FM demodulator shifts the local oscillator frequency in inverse proportion to the IF deviation due to modulation.

Active IF Filter

The first section of the IF filter (AF1A) is a second-order low-pass Sallen-Key circuit with its cut-off frequency determined by internal 2.2kΩ resistors and external capacitors C₇ and C₈. The second section (AF1B) consists of a first-order bandpass filter with the lower

A complete FM radio on a chip

AN192

limit of the passband determined by an internal 4.7kΩ resistor and external capacitor C₁₁. The upper limit of the passband is determined by an internal 4.7kΩ resistor and external capacitor C₁₀. The final section of the IF filter consists of a first-order low-pass network comprising an internal 12kΩ resistor and external capacitor C₁₂. The overall IF filter therefore consists of a fourth-order low-pass section and a first-order high-pass section. Design equations for the filter are given in Figure 3. Figure 4 shows the measured response for the filter.

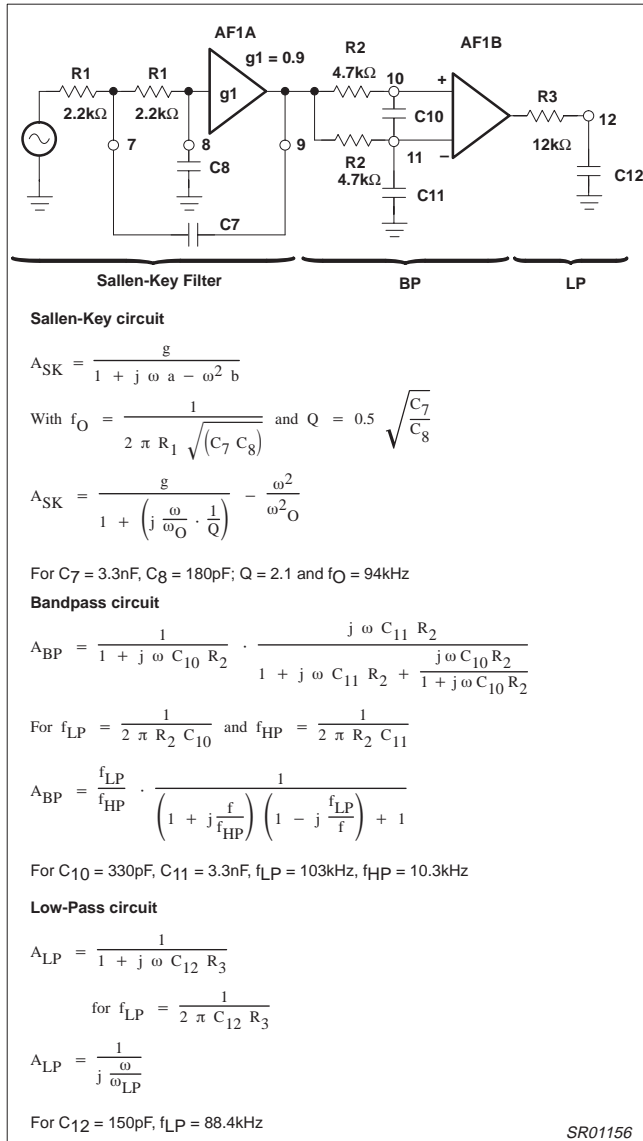

Figure 3. IF Filter of the TDA7000

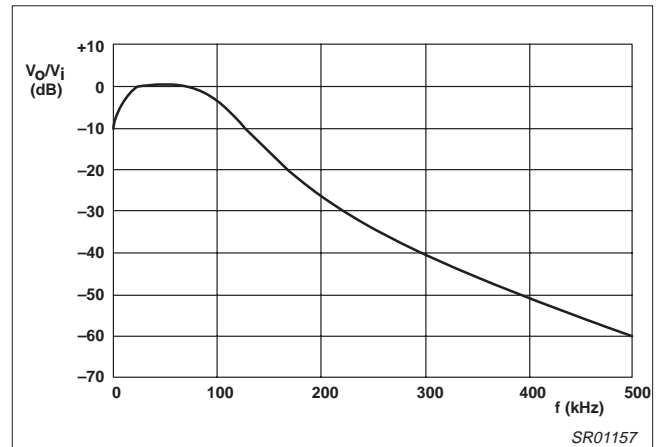

Figure 4. Measured Response of the IF Filter

FM Demodulator

The quadrature FM demodulator M2 converts the IF variations due to modulation into an audio frequency voltage. It has a conversion gain of -3.6V/MHz and requires phase quadrature inputs from the IF limiter/amplifier. As shown in Figure 5, the 90° phase shift is provided by an active all-pass filter which has about unity gain at all frequencies but can provide a variable phase shift, dependent on the value of external capacitor C₁₇.

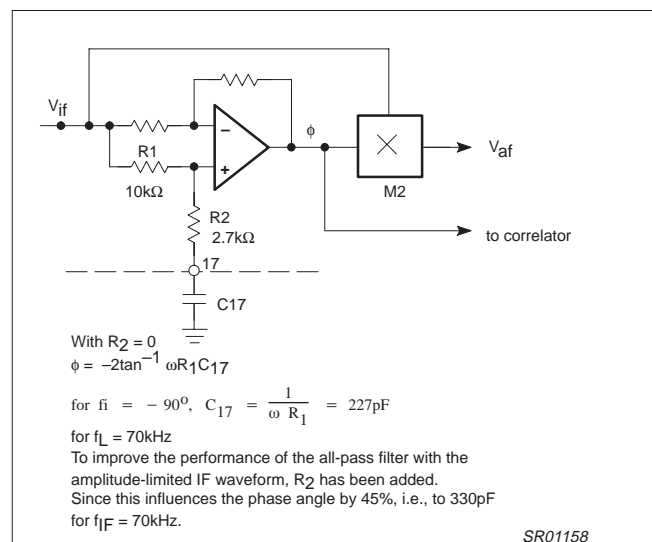

Figure 5. FM Demodulator Phase Shift Circuit (All-Pass Filter)

A complete FM radio on a chip

AN192

IF Swing Compression With the FLL

With a nominal IF as low as 70kHz, severe harmonic distortion of the audio output would occur with an IF deviation of $\pm 75\text{kHz}$ due to full modulation of a received FM broadcast signal. The FLL of the TDA7000 is therefore used to compress the IF swing by using the audio output from the FM demodulator to shift the local oscillator frequency in opposition to the IF deviation. The principle is illustrated in Figure 6, which shows how an IF deviation of 75kHz is compressed to about 15kHz. The THD is thus limited to 0.7% with $\pm 22.5\text{kHz}$ modulation, and to 2.3% with $\pm 75\text{kHz}$ modulation.

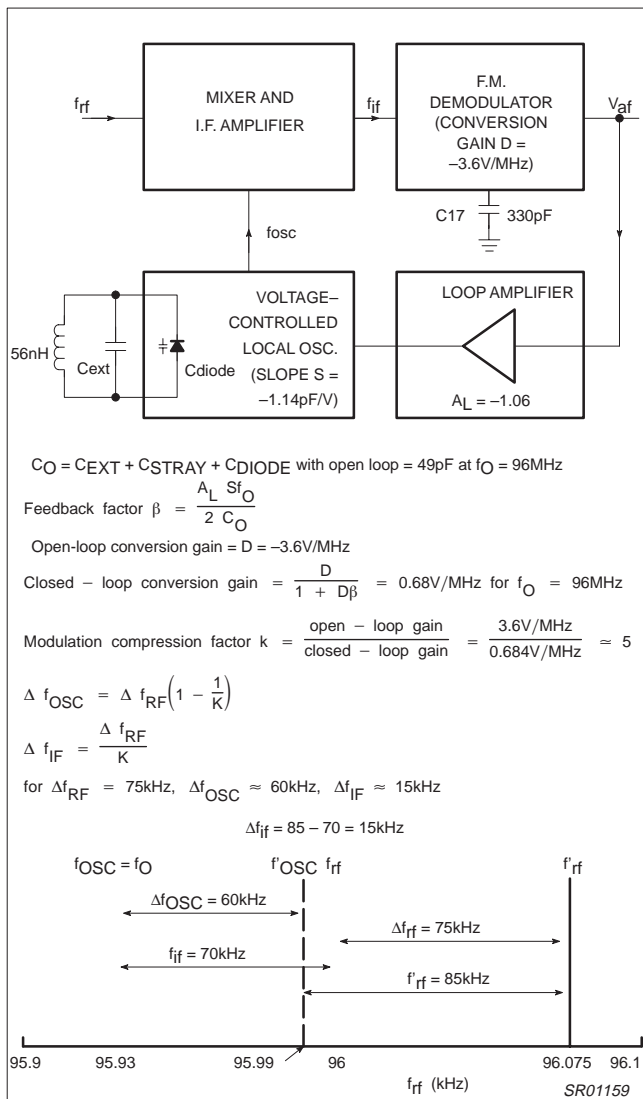

Figure 6. IF Swing Compression with the FLL

Correlation Muting System With Open FLL

A well-known difference between FM and AM is that, for FM, each station is received in at least three tuning positions. Figure 7 shows the frequency spectrum of the output from the demodulator of a typical portable FM radio receiving an RF carrier frequency-modulated with a tone of constant frequency and amplitude. In addition to the audio response at the correct tuning point in the center of Figure 7,

there are two side responses due to the flanks of the demodulator S-curve. Because the flanks of the S-curve are non-linear, the side responses have increased harmonic distortion. In Figure 7, the frequency and intensity of the side responses are functions of the signal strength, and they are separated from the correct tuning point by amplitude minima. However, in practice, the amplitude minima are not well defined because the modulation frequency and index are not constant and, moreover, the side response of adjacent channels often overlap.

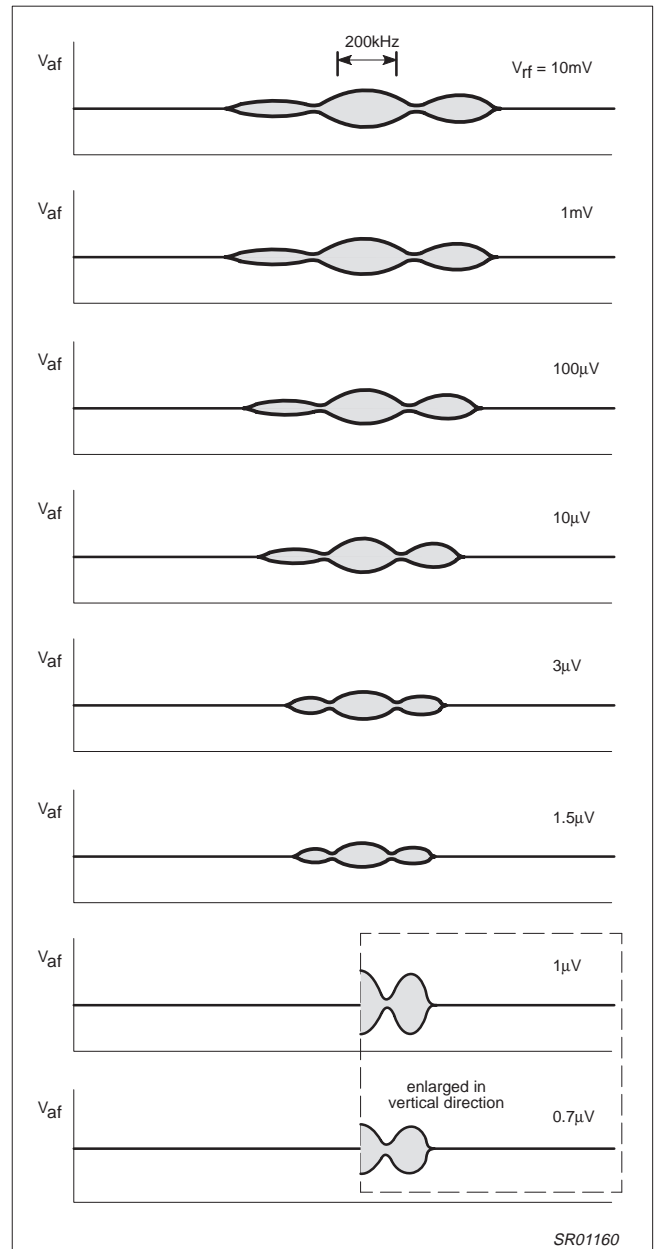

Figure 7. Audio Signal of a Typical Portable Radio as a Function of Tuned Frequency With RF Input as a Parameter. The Modulation and Amplitude are Both Constant.

A complete FM radio on a chip

AN192

High performance FM radios incorporate squelch systems such as signal strength-dependent muting and tuning deviation-dependent muting to suppress side responses. They also have a tuning meter to facilitate correct tuning. Although the TDA7000 is mainly intended for use in portables and clock radios, it incorporates a very effective new correlation muting system which suppresses interstation noise and spurious responses due to detuning to the flanks of the demodulator S-curve. The muting system is controlled by a circuit which determines the correlation between the waveform of the IF signal and an inverted version of it which is delayed (phase-shifted) by half the period of the nominal IF (180°). A noise generator works in conjunction with the muting system to give an audible indication

High performance FM radios incorporate squelch systems such as signal strength-dependent muting and tuning deviation-dependent muting to suppress side responses. They also have a tuning meter to facilitate correct tuning. Although the TDA7000 is mainly intended for use in portables and clock radios, it incorporates a very effective new correlation muting system which suppresses interstation noise and spurious responses due to detuning to the flanks of the demodulator S-curve. The muting system is controlled by a circuit which determines the correlation between the waveform of the IF signal and an inverted version of it which is delayed (phase-shifted) by half the period of the nominal IF (180°). A noise generator works in conjunction with the muting system to give an audible indication of incorrect tuning.

Figure 8 illustrates the function of the muting system. Signal IF' is derived by delaying the IF signal by half the period of the nominal IF and inverting it. With correct tuning as shown in Figure 8a, the waveforms of the two signals are identical, resulting in large correlation. In this situation, the audio signal is not muted. With detuning as shown in Figure 8b, signal IF' is phase-shifted with respect to the IF signal. The correlation between the two waveforms is therefore small and the audio output is muted. Figure 8c shows that, because of the low Q of the IF filter, noise causes considerable fluctuations of the period of the IF signal waveform. There is then small correlation between the two waveforms and the audio is muted. The correlation muting system thus suppresses noise and side responses due to detuning to the flanks of the demodulator S-curve. Since the mute threshold is much lower than that obtained with most other currently-used muting systems, this muting system is ideal for portable radios which must often receive signals with a level only slightly above the input noise.

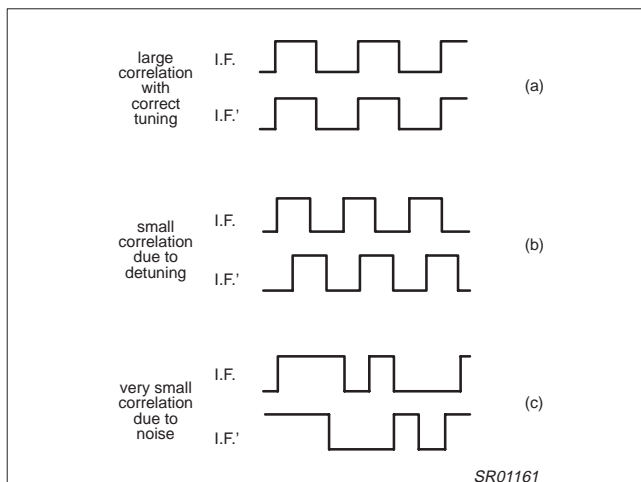

Figure 8. Function of the Correlation Muting System

As shown in Figure 9, the correlation muting circuit consists of all-pass filter AP2 connected in series with FM demodulator all-pass filter AP1 and adjusted by an external capacitor to provide a total phase shift of 180°. The output from AP2 is applied to mixer M3 which determines the correlation between the undelayed limited IF signal at one of its inputs and the delayed and inverted version of it at its other input. The output from mixer M3 controls a muting circuit which feeds the demodulated audio signal to the output when the correlation is high, or feeds the output from a noise source to the output to give an audible indication of incorrect tuning when the correlation is low. The switching of the muting circuit is progressive (soft muting) to prevent the generation of annoying audio transients. The output from mixer M3 is available externally at Pin 1 and can also be used to drive a detuning indicator.

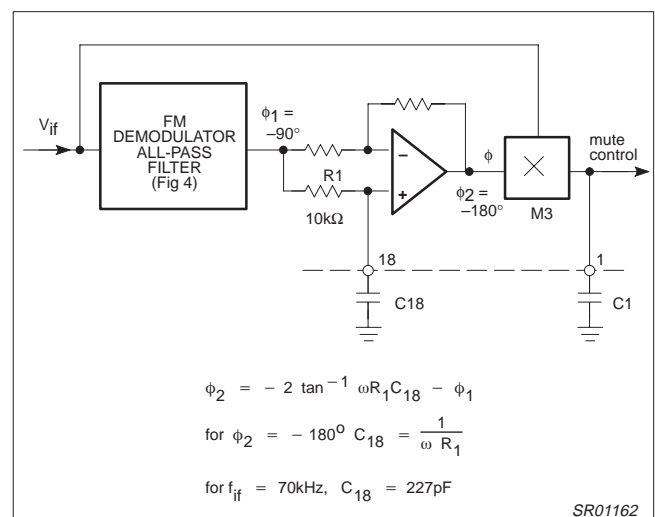

Figure 9. Correlator of the TDA7000

Figure 10 shows that there are two regions where the demodulated audio signal is fed to the output because the muting is inactive. One region is centered on the correct tuning point f_L . The other is centered on the image frequency $-f_L$. The image response is therefore not suppressed by the muting system when the frequency-locked loop is open. When the loop is closed, the time constant of the muting system, which is determined by external capacitor C_1 , prevents the image response being passed to the audio output. This is described under the next heading.

A complete FM radio on a chip

AN192

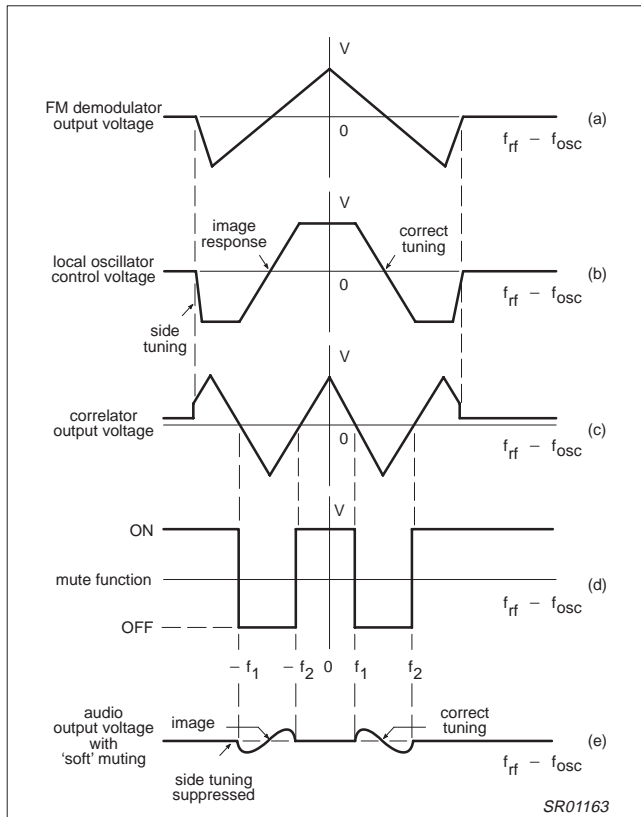

Figure 10. Operation of the Correlation Muting System with Open-Loop FLL

Correlation Muting System With Closed FLL

The closed-loop response of the FLL is shown in Figure 11, in which the point of origin is the nominal IF ($f_{RF} - f_{OSC} = f_L$). With correct tuning, the muting is inactive and the audio signal is fed to the output. Spurious responses due to the flanks of the demodulator S-curve which occur outside the IF band $-f_2$ to f_2 are suppressed because the muting is active. Fast transients of the audio signal due to locking of the loop (A and B), and to loss of lock (C and D) are suppressed in two ways.

Lock and loss of lock transients B and D occur when the IF is greater than f_2 and are therefore suppressed because the muting is active. The situation is different during loss of lock transient C because the muting is only active for the last part of the transient. To completely suppress this transient, capacitor C_1 in Figure 2 holds the muting control line positive (muting active) during the short interval while the IF traverses from $-f_1$ to $-f_2$. The same applies for

lock transient A during the short interval while the IF traverses from $-f_2$ to $-f_1$. Since the image response occurs halfway between $-f_1$ and $-f_2$, it is also suppressed.

Figure 12 shows the audio output from the TDA7000 radio as a function of tuned frequency with aerial signal level as a parameter. Compared with the similar diagram for a typical conventional portable radio (Figure 7), there are three important improvements:

1. There are no side responses due to the flanks of the demodulator S-curve. This is due to the action of the correlation muting system (soft mute) which combines the function of a detuning-dependent muting system with that of a signal strength-dependent muting system.
2. The correct tuning frequency band is wide, even with weak aerial signals. This is due to the AFC action of the FLL which reduces a large variation of aerial input frequency (equivalent to detuning) to a small variation of the IF. There is no audio distortion when the radio is slightly detuned.
3. Although the soft muting system remains operative with low level aerial signals, there is no degradation of the audio signal under these conditions. This is due to the high gain of the IF limiter/amplifier which provides -3dB limiting of the IF signal with an aerial input level of $1.5\mu\text{V}$. However, the soft muting action does reduce the audio output level with low level aerial signals.

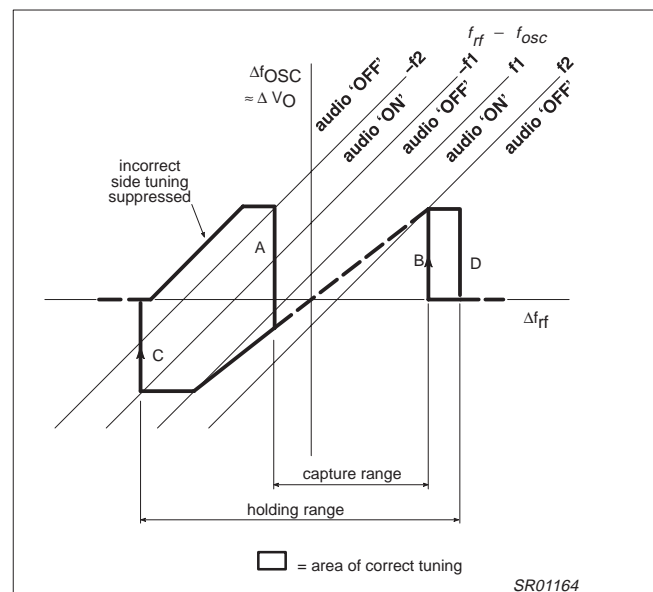

Figure 11. Closed-Loop Response of the FLL

A complete FM radio on a chip

AN192

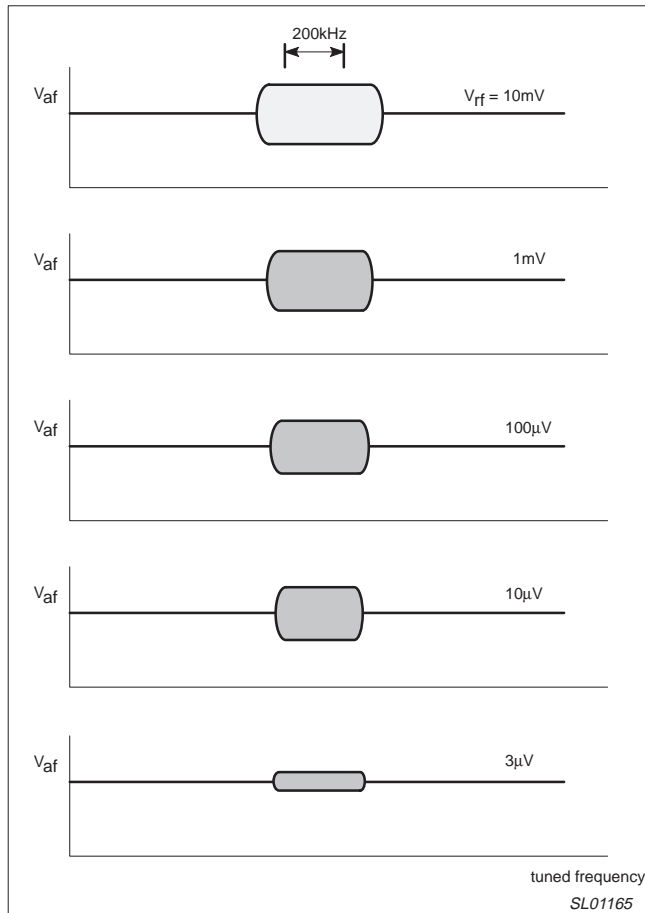

Figure 12. Audio Signal of the TDA7000 as a Function of the Tuned Frequency with RF Input as a Parameter

RECEIVER CIRCUITS

Circuits With Variable Capacitor Tuning

The circuit diagram of the complete mono FM radio is given in Figure 2. An experimental printed-wiring board layout is given in Figure 13. Special attention has been paid to supply lines and the positioning of large-signal decoupling capacitors.

The functions of the peripheral components of Figure 2 not already described are as follows:

C_1 – Determines the time constant required to ensure muting of audio transients due to the operation of the FLL.

C_2 – Together with R_2 determines the time constant for audio de-emphasis (e.g., $R_2C_2 = 40\mu\text{s}$).

C_3 – The output level from the noise generator during muting increases with increasing value of C_3 . If silent mute is required, C_3 can be omitted.

C_4 – Capacitor for the FLL filter. It eliminates IF harmonics at the output of the FM demodulator. It also determines the time constant for locking the FLL and influences the frequency response.

C_5 – Supply decoupling capacitor which must be connected as close as possible to Pin 5 of the TDA7000.

C_7 to C_{12} , C_{17} and C_{18} – Filter and demodulator capacitors. The values shown are for an IF of 70kHz. For other intermediate frequencies, the values of these capacitors must be changed in inverse proportion to the IF change.

C_{14} – Decouples the reverse RF input. It must be connected to the common return via a good quality short connection to ensure a low-impedance path. Inductive or capacitive coupling between C_{14} and the local oscillator circuit or IF output components must be avoided.

C_{15} – Decouples the DC feedback for IF limiter/amplifier LA_1 .

C_{19} and C_{21} – Local oscillator tuning capacitors. Their values depend on the required tuning range and on the value of tuning capacitor C_{20} .

C_{22} , C_{23} , L_1 , L_2 – The values given are for an RF bandpass filter with $Q = 4$ for the European and USA domestic FM broadcast band (87.5MHz to 108MHz). For reception of the Japanese FM broadcast band (76MHz to 91MHz), L_1 must be increased to 78nH and L_2 must be increased to 150nH. If stopband attenuation for high level AM or TV signals is not required, L_2 and C_{22} can be omitted and C_{23} changed to 220pF.

R_2 – The load for the audio output current source. It determines the audio output level, but its value must not exceed $22\text{k}\Omega$ for $V_{CC} = 4.5\text{V}$, or $47\text{k}\Omega$ for $V_{CC} = 9\text{V}$.

A complete FM radio on a chip

AN192

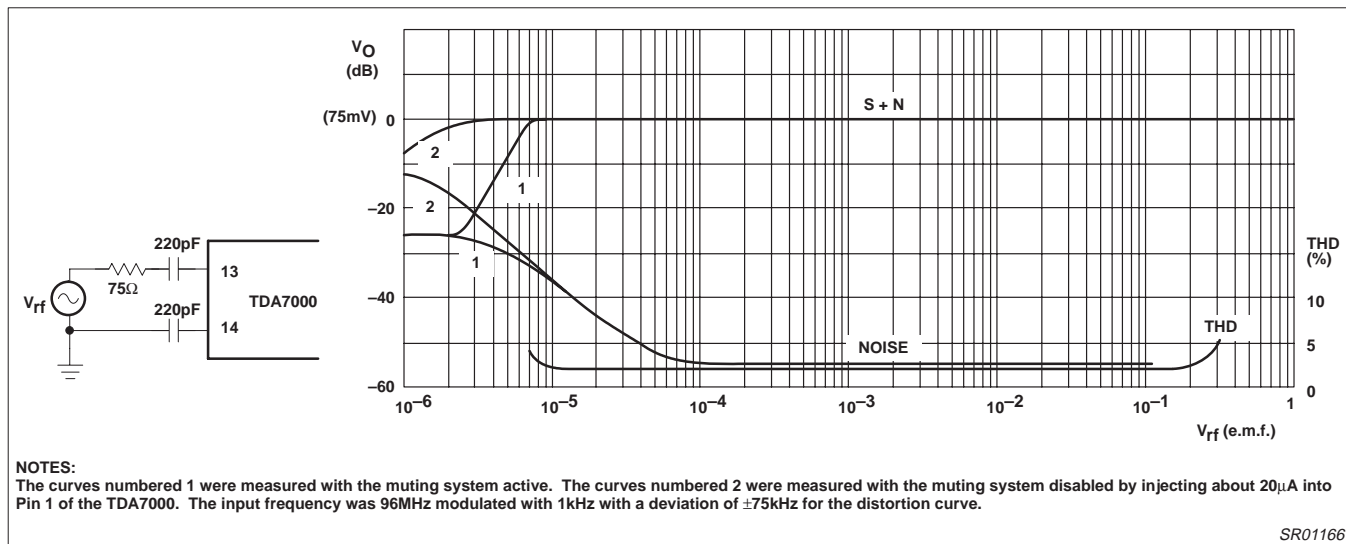

Figure 13. Audio Output as a Function of Input EMF

PERFORMANCE OF THE CIRCUIT

V_{CC}=4.5V, T_A=25°C f_{RF}=96MHz, V_{RF}=0.2mV EMF from a 75Ω source, modulated with Δf=±22.5kHz, f_M=1kHz. Noise voltage measured unweighted over the bandwidth 300Hz to 20kHz, unless otherwise specified.

SYMBOL	PARAMETER	TYP	MAX
EMF	<80>Sensitivity (EMF voltage)for -3dB limiting: muting disabled	1.5	
EMF	for -3dB muting	6	
EMF	for (S+N)/N=26dB	5.5	
EMF	<80>Signal handling (EMF voltage) for THD<10%; Δf=±75kHz	200	
(S+N)/N	Signal-to-noise ratio (see Figure 14)	60	
THD	<80>Total harmonic distortion (see Figure 14) at Δf=±22.5kHz		
THD	at Δf=±75kHz		
AMS	<80>AM suppression (ratio of the AM output signalreferred to the FM output signal) FM signal: f _m =1kHz;Δf=±75kHz AM signal: f _m =1kHz; m=80%		
RR	10		
V _{6-5 RMS}	250		
Δf _{OSC}	80Variation of oscillator frequencywith supply voltage (ΔV _{CC} =1V)	60	
S ₊₃₀₀	45		
S ₋₃₀₀	35		
Δf _{RF}	AFC range	±300	
B	80Audio bandwidth at ΔV _O =3dBmeasured with pre-emphasis (t=50μs)	10	
V _{O(RMS)}	80AF output voltage (RMS value)at R _L =22kΩ	75	
R _L		22	
R _L		47	

A complete FM radio on a chip

AN192

Circuit With Variable-Capacitance Diode Tuning

Since it is only necessary to tune the local oscillator coil, it is very simple to modify the circuit of Figure 2 for variable-capacitance diode tuning. The modifications are shown in Figure 14. A circuit board layout for the modified receiver and a photograph of a complete laboratory model are shown in Figure 15.

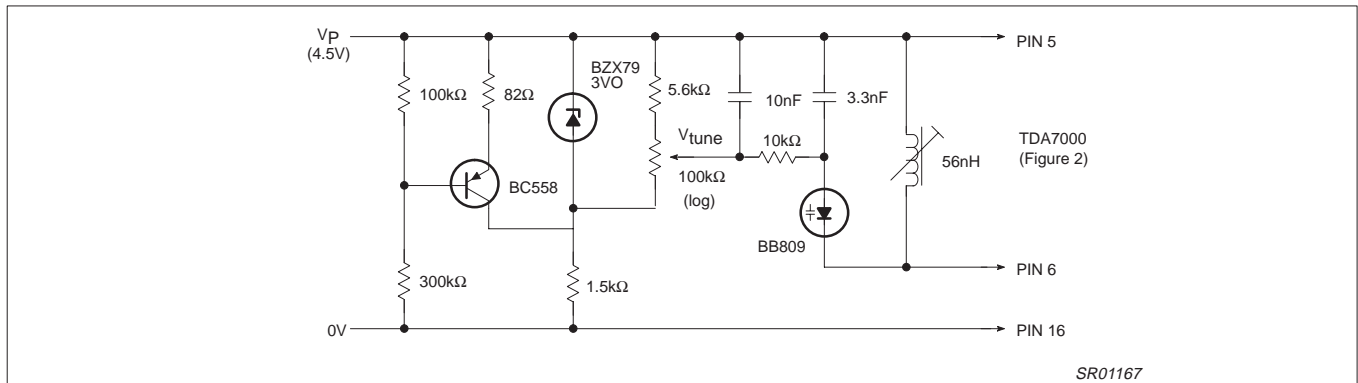

Figure 14. Variable-Capacitance Diode Tuning for the Local Oscillator. Additional Measures Must be Taken to Ensure Temperature Stability.

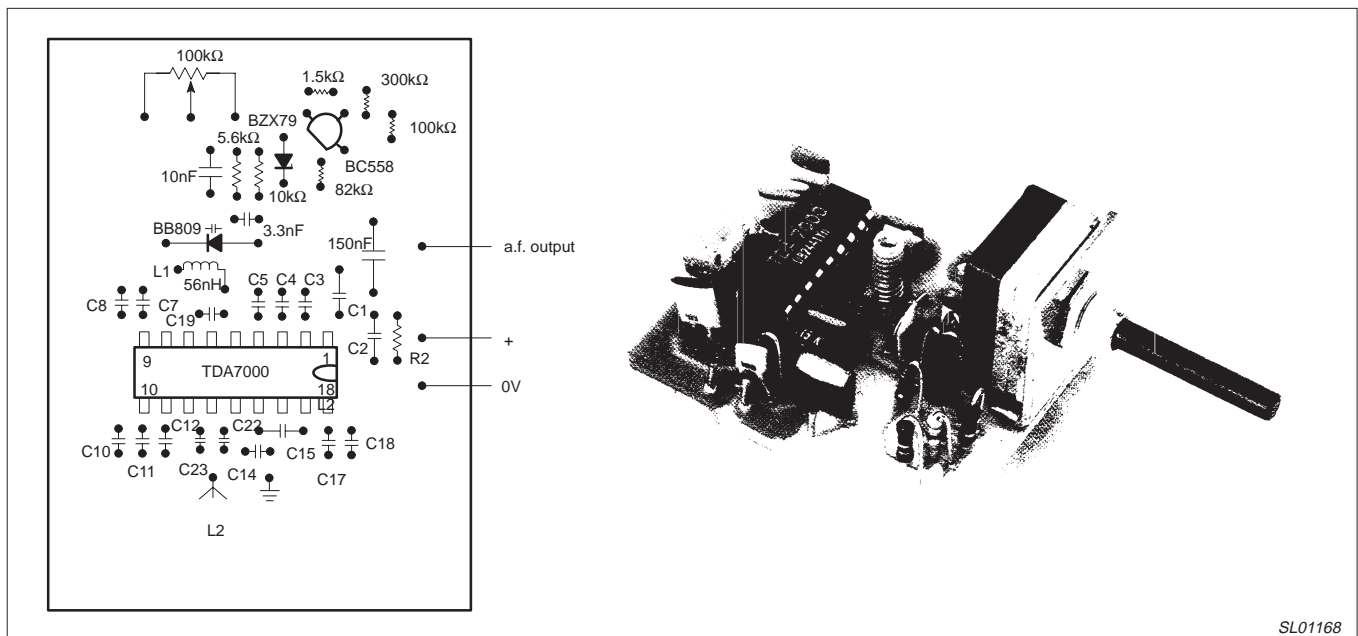

Figure 15. Circuit Board Layout and Complete Model of a TDA7000 Radio With Variable-Capacitance Diode Tuning

A complete FM radio on a chip

AN192

Narrow-Band FM Receiver

The TDA7000 can also be used for reception of narrowband FM signals. In this case, the local oscillator is crystal-controlled (as shown in Figure 16) and there is therefore hardly any compression of the IF swing by the FLL. The deviation of the transmitted carrier frequency due to modulation must therefore be limited to prevent severe distortion of the demodulated audio signal.

The component values in Figure 17 result in an IF of 4.5kHz and an IF bandwidth of 5kHz (Figure 17). If the IF is multiplied by N, the

values of capacitors C₁₇ and C₁₈ in the all-pass filters and the values of filter capacitors C₇, C₈, C₁₀, C₁₁, and C₁₂ must be multiplied by 1/N. For improved IF selectivity to achieve greater adjacent channel attenuation, second-order networks can be used in place of C₁₀ and C₁₁.

In this circuit the detuning noise generator is not used. Since the circuit is mainly for reception of audio signals, the audio output must be passed through a low-pass Chebyshev filter to suppress IF harmonics.

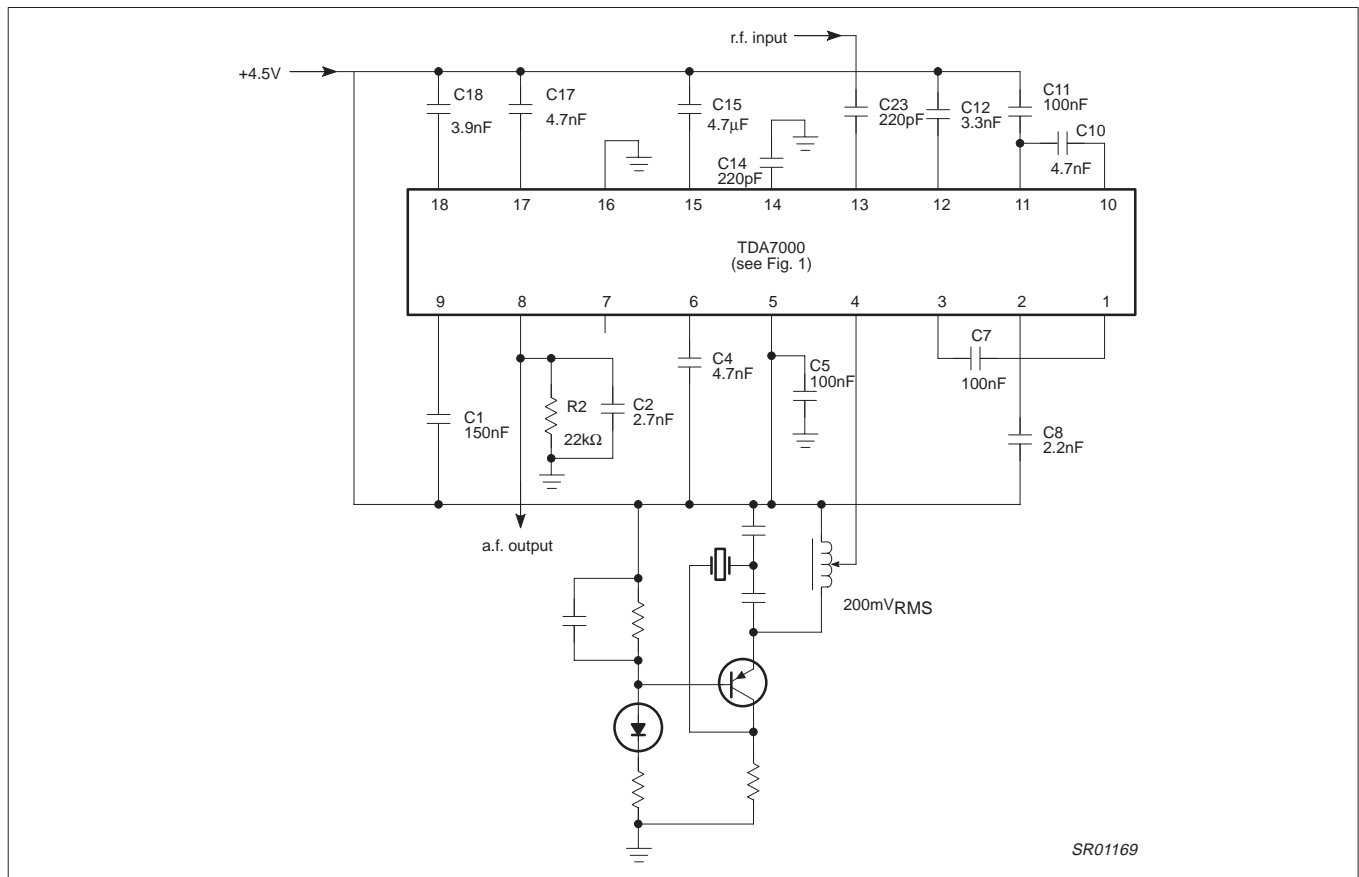

Figure 16. A Narrowband FM Receiver With a Crystal-Controlled Local Oscillator

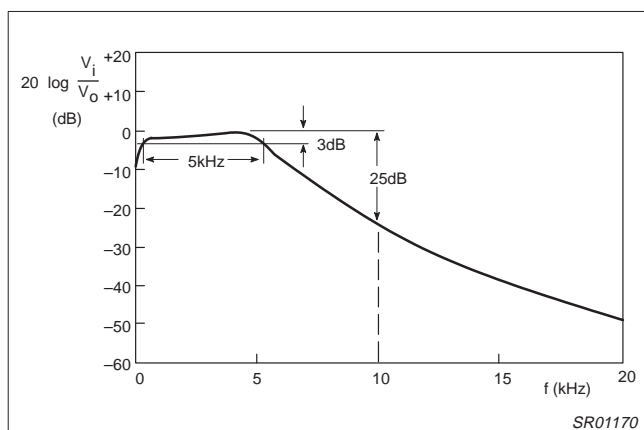

Figure 17. IF Selectivity for the Narrowband FM Receiver

A complete FM radio on a chip

AN192

AUDIO AMPLIFIER AND DETUNING INDICATOR CIRCUITS

Audio output stages suitable for use with the TDA7000 are shown in Figures 18 and 19. Figure 20 shows how the muting signal can be used to operate an LED to give an indication of detuning.

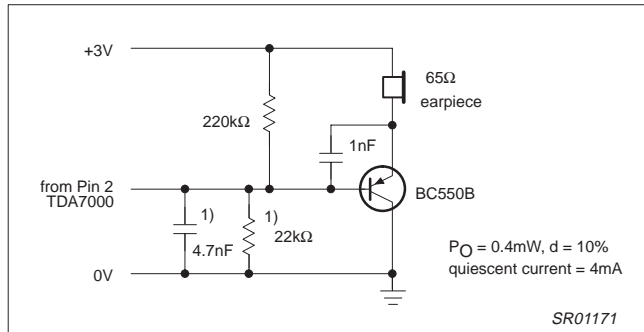

Figure 18. A 0.4mW Transistor Audio Output Stage Without Volume Control for Driving an Earpiece

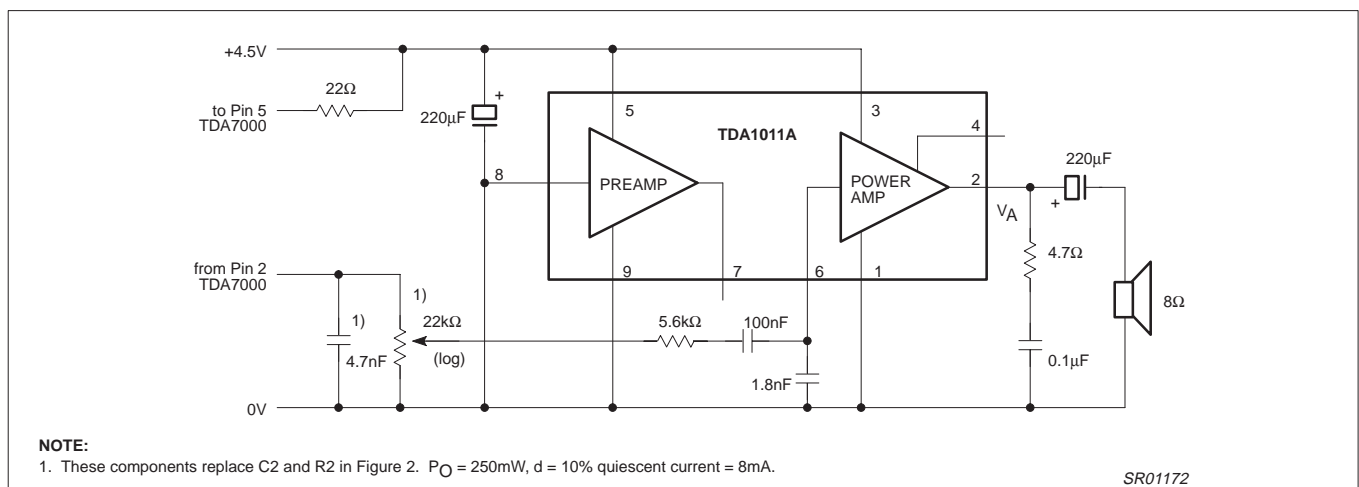

Figure 19. An Integrated 250mW Audio Output Stage

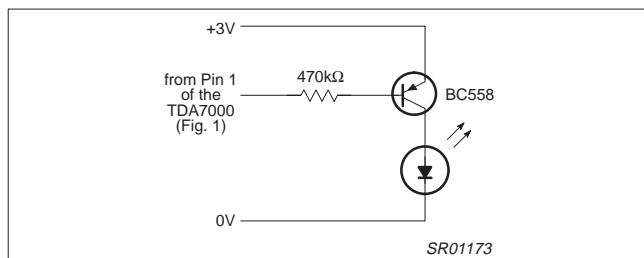

Figure 20. A Detuning Indicator Driven by the Mute Signal From the TDA7000

ACKNOWLEDGEMENTS

The authors wish to acknowledge the information provided by D. Kasperkovitz and H.v. Rump for incorporation in this article.

REFERENCE

NOW, W. and SIEWERT, I., "Integrated circuits for hi-fi radios and tuners", Electronic Components and Applications, Vol. 4, No. 1, November 1981, pp. 11 to 27.

A complete FM radio on a chip

AN192

NOTES

A complete FM radio on a chip

AN192

Philips Semiconductors and Philips Electronics North America Corporation reserve the right to make changes, without notice, in the products, including circuits, standard cells, and/or software, described or contained herein in order to improve design and/or performance. Philips Semiconductors assumes no responsibility or liability for the use of any of these products, conveys no license or title under any patent, copyright, or mask work right to these products, and makes no representations or warranties that these products are free from patent, copyright, or mask work right infringement, unless otherwise specified. Applications that are described herein for any of these products are for illustrative purposes only. Philips Semiconductors makes no representation or warranty that such applications will be suitable for the specified use without further testing or modification.

LIFE SUPPORT APPLICATIONS

Philips Semiconductors and Philips Electronics North America Corporation Products are not designed for use in life support appliances, devices, or systems where malfunction of a Philips Semiconductors and Philips Electronics North America Corporation Product can reasonably be expected to result in a personal injury. Philips Semiconductors and Philips Electronics North America Corporation customers using or selling Philips Semiconductors and Philips Electronics North America Corporation Products for use in such applications do so at their own risk and agree to fully indemnify Philips Semiconductors and Philips Electronics North America Corporation for any damages resulting from such improper use or sale.

Philips Semiconductors
811 East Arques Avenue
P.O. Box 3409
Sunnyvale, California 94088-3409
Telephone 800-234-7381

© Copyright Philips Electronics North America Corporation 1991
All rights reserved. Printed in U.S.A.