

# HA13481S

## Three Phase Motor Driver with Speed Discriminator

### Description

The HA13481S is hall sensorless three-phase brushless DC motor driver for HDD and, have following functions and features.

### Functions

- Back-EMF detector
- Start up circuit
- Running commutation
- Output amp. (Driving capability; 2.0 A/phase)
- Zerocross detector
- Programmable frequency divider
- OSC
- Speed discriminator
- Charge pump
- Control amp.
- Current limiter
- Start up monitor
- Ready signal
- Chip enable
- Motor on/off control
- Internal protector (OTSD, LVI)

### Features

- Hall sensorless
- Low saturation voltage; 2.0 V max. (@ $I_O = 1.0$  A)
- Applicable for both 4 MHz and 5 MHz clock
- Small surface mount package ( $\theta_j - c \leq 7^\circ\text{C/W}$ )

### Ordering Information

Type No.	Package
HA13481S	MP-26DT

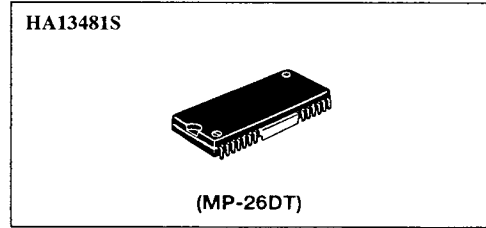

### Pin Arrangement

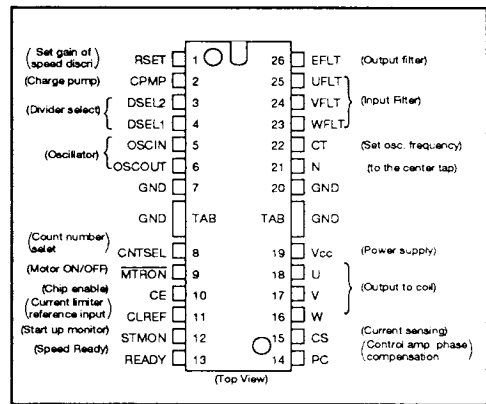

Block Diagram

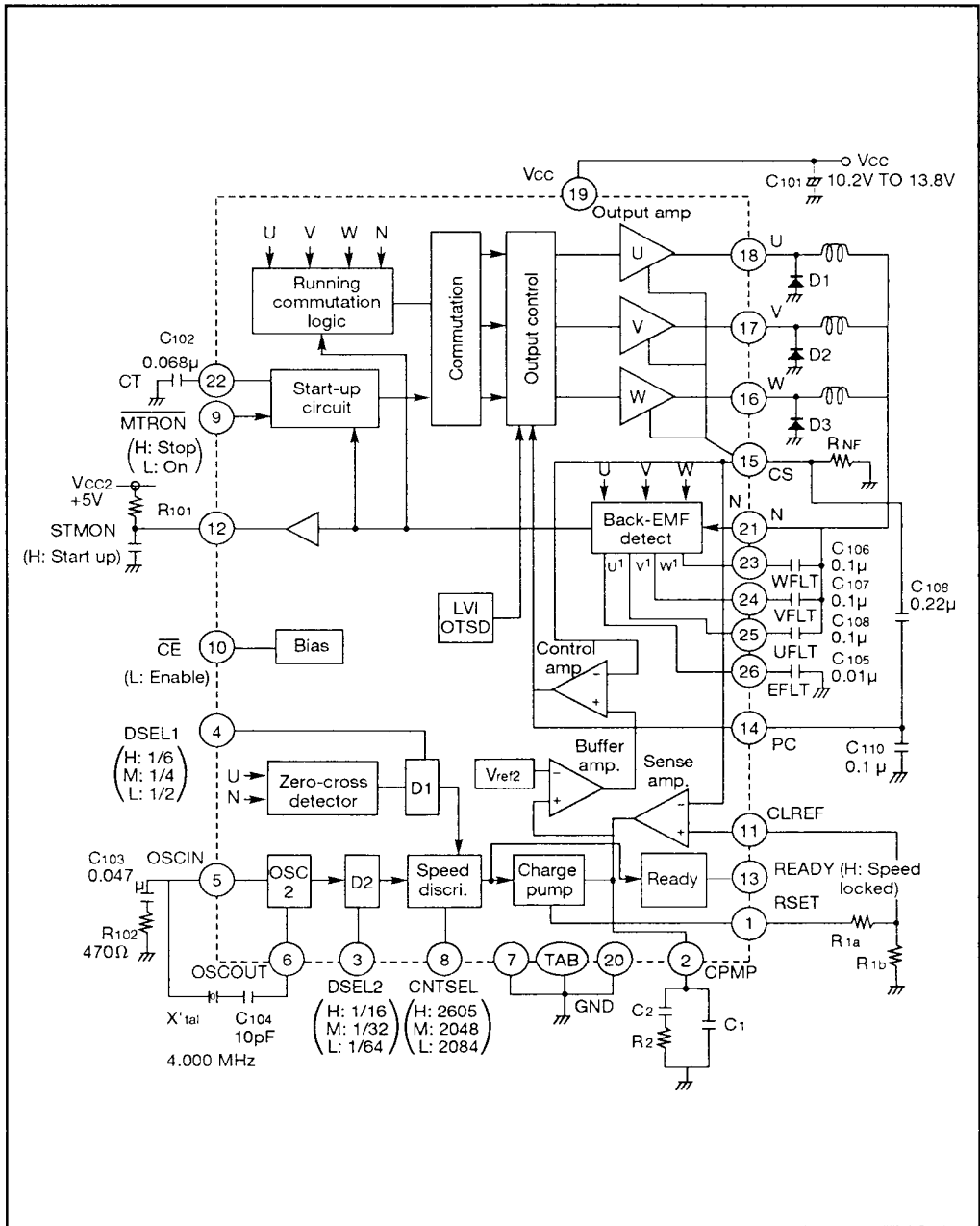

External Components

Parts No.	Recommended Value	Purpose	Notes
R <sub>101</sub>	47 kΩ ≤ R <sub>101</sub> ≤ 1 MΩ	Pull up	1
R <sub>102</sub>	470 kΩ	Oscillation stability	2
R <sub>1a</sub>	3.9 kΩ	V/I converter	3
R <sub>1b</sub>	1.3 kΩ	V/I converter	
R <sub>2</sub>	560 kΩ	Integral constant	
C <sub>101</sub>	10 μF and 0.1 μF	Power supply by-passing	
C <sub>102</sub>	0.068 μF	Oscillation	1
C <sub>103</sub>	0.047 μF	Oscillation stability	2
C <sub>104</sub>	10 μF ± 1%	AC-coupling	
C <sub>105</sub>	0.01 μF	Output filter	4
C <sub>106, C<sub>107, C<sub>108</sub></sub></sub>	0.1 μF	Input filter	5
C <sub>109</sub>	0.22 μF	Control amp phase compensation	
C <sub>110</sub>	0.1 μF		
C <sub>111</sub>	—	Time constant	1
C <sub>1</sub>	0.022 μF	Integral constants	3
C <sub>2</sub>	0.22 μF		
D <sub>1, D<sub>2, D<sub>3</sub></sub></sub>	—	Output clamp	6
Xtal	—	Oscillation	7
R <sub>NF</sub>	—	Current sensing	8

Notes: 1. By adding the C<sub>111</sub> on pin 12, the excitation frequency of the motor transit from high frequency to low frequency. By this operation, the back motion of the motor at starting condition can be minimized. The oscillation frequency f<sub>osc1</sub>, the C<sub>102</sub> and the time constant C<sub>111</sub> • R<sub>101</sub> are determined by following equations.

$$2 \times 10^{-3} \times \frac{N_o \cdot P}{V_E} < f_{osc1} < 0.25 \sqrt{\frac{I_o \cdot K_T \cdot P}{J}} \quad [\text{Hz}] \dots\dots\dots(1)$$

$$C_{102} = \frac{1}{f_{osc1} \cdot (V_{th1} - V_{th2})} \cdot \frac{I_{ts} \cdot I_{tf}}{I_{ts} + I_{tf}} = 0.52 / f_{osc1} \quad [\mu\text{F}] \dots\dots\dots(2)$$

$$C_{111} \cdot R_{101} > \frac{1}{I_n [V_{CC2} / (V_{CC2} - 2.5)] \cdot f_{osc1}} \quad [\text{S}] \dots\dots\dots(3)$$

- Where,  
 N<sub>o</sub> : Standard rotation speed (rpm)  
 P : Number of pole  
 V<sub>i</sub> : Back EMF at running (Vp-p)  
 I<sub>o</sub> : Starting up current (A)  
 K<sub>T</sub> : Torque constant (kg • cm/A)  
 J : Morment of inertia (kg • cm • S<sup>2</sup>)

2. Unnecessary below 4 MHz oscillation frequency.  
 3. The integral constant can be designed as

$$\omega_o \leq \frac{2\pi}{10 \cdot m} \times \frac{N_o}{60} \times \frac{P}{2} \dots\dots\dots(4)$$

$$\frac{R_2}{R_{1a} + R_{1b}} = \frac{4}{9.55} \times \frac{R_{NF} \cdot J \cdot \omega_o \cdot N_o}{V_{ref2} \cdot K_T \cdot G_{CTL}} \dots\dots\dots(5)$$

$$R_{1a} + R_{1b} \leq 25 \text{ k}\Omega \dots\dots\dots(6)$$

$$C_1 = 1 / (\sqrt{10} \cdot \omega_o \cdot R_2) \quad [\text{F}] \dots\dots\dots(7)$$

$$C_2 = 10 \cdot C_1 \quad [\text{F}] \dots\dots\dots(8)$$



where

$V_{re2}$  : output voltage at pin 1 (= 1.0 V) [V]

$K_T$  : torque constant [kg • cm/A]

$G_{CTL}$  : gain from pin 2 to pin 15 (= 0.5)

4. When the  $C_{102}$  is less than 0.047  $\mu$ F, the capacitor  $C_{105}$  is necessary.

5. Select the value of  $C_{106}$ ,  $C_{107}$  and  $C_{108}$  as follows.

4 pole motor  $\rightarrow$  0.22 ( $\mu$ F)

8 pole motor  $\rightarrow$  0.1 ( $\mu$ F)

12 pole motor  $\rightarrow$  0.068 ( $\mu$ F)

6. Some motors require these components.

7. Osc. frequency  $f_{osc2}$  is determined by the following equation:

$$f_{osc2} = \frac{N_o}{60} \times \frac{P}{2} \times \frac{n}{m} \times (1 - 0.5) \dots\dots\dots(9)$$

where,

$N_o$  : Standard rotation speed (rpm)

$P$  : Number of pole

$l$  : Count number

$l = 2084$  (@ Pin 8 = Low)

$= 2048$  (@ Pin 8 = Open)

$= 2605$  (@ Pin 8 = High)

$m$  : Dividing ratio on divider 1

$m = 2$  (@ Pin 4 = Low)

$= 4$  (@ Pin 4 = Open)

$= 6$  (@ Pin 4 = High)

$n$  : Dividing ratio on divider 2

$n = 64$  (@ Pin 3 = Low)

$= 32$  (@ Pin 3 = Open)

$= 16$  (@ Pin 3 = High)

In order to minimize the error of rotation speed, select the dividing ratio  $m$  as follows:

at 4 pole motor  $\rightarrow m = 2$

at 8 pole motor  $\rightarrow m = 4$

at 12 pole motor  $\rightarrow m = 6$

**example** (for  $N_o = 3,600$  rmp)

Pin 8	Pin 3	$f_{osc}$ [MHz]		
		Pin 4 = Low (for 4 pole)	Pin 4 = Open (for 8 pole)	Pin 4 = High (for 12 pole)
Low	Low	8.000	8.000	8.000
Low	Open	4.000	4.000	4.000
Low	High	2.000	2.000	2.000
Open	Low	7.862	7.862	7.862
Open	Open	3.931	3.931	3.931
Open	High	1.966	1.966	1.966
High	Low	—	—	—
High	Open	5.000	5.000	5.000
High	High	2.500	2.500	2.500

8. Output maximum current is determined by the following equation:  $I_{omax} = V_{CLREF}/R_{NF} \dots\dots\dots(10)$

9. Fig. 1 shows the snubber circuit to reduce the spike noise at phase commutation.

10. Fig. 2 shows the application to use external clock with TTL level.

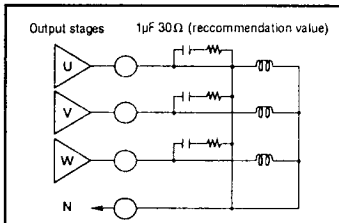

Figure 1 Snubber circuit

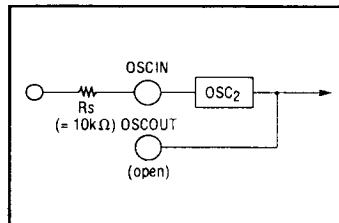
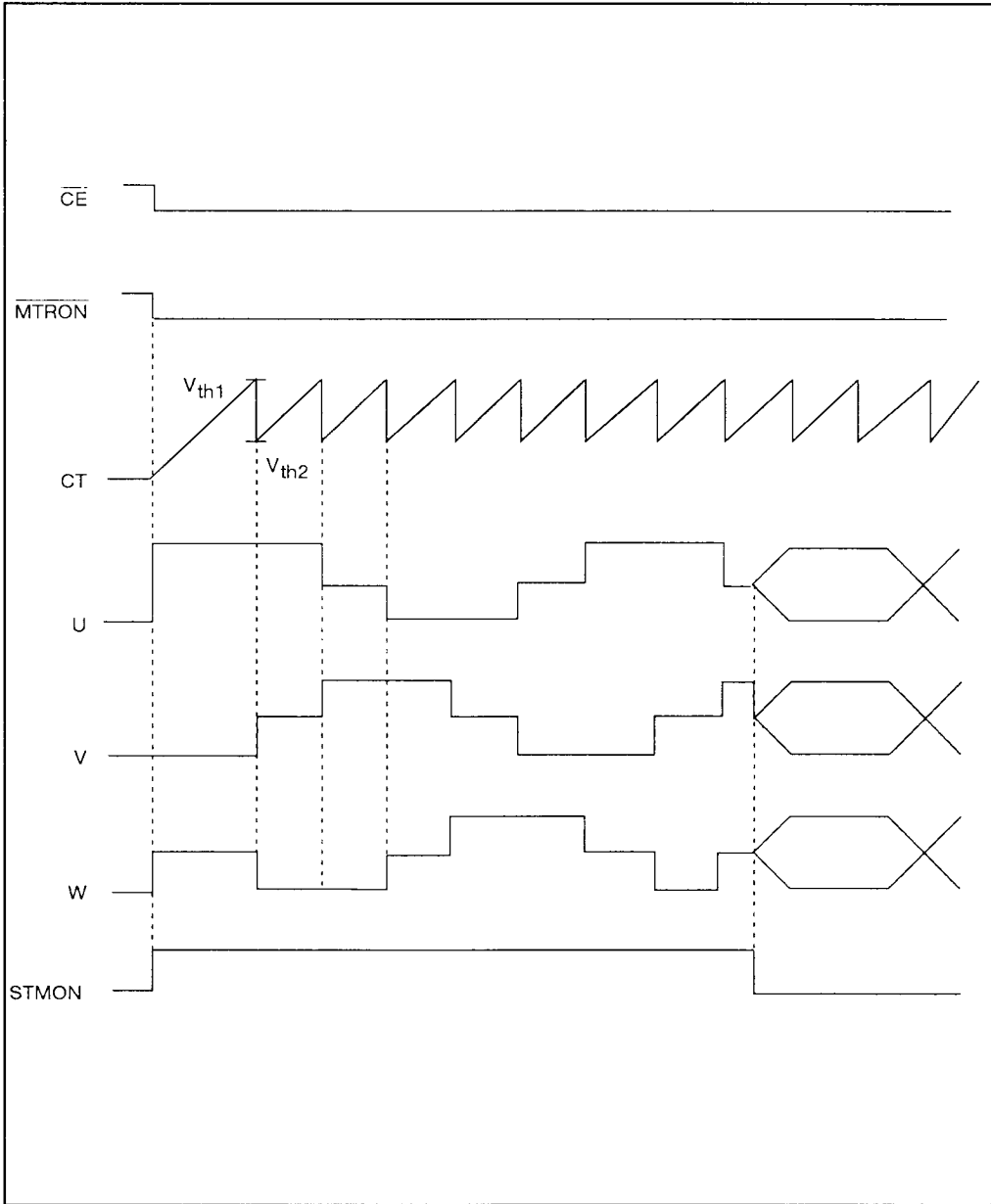

Figure 2 Application for external CLK



Timing Chart

Start-up



Running

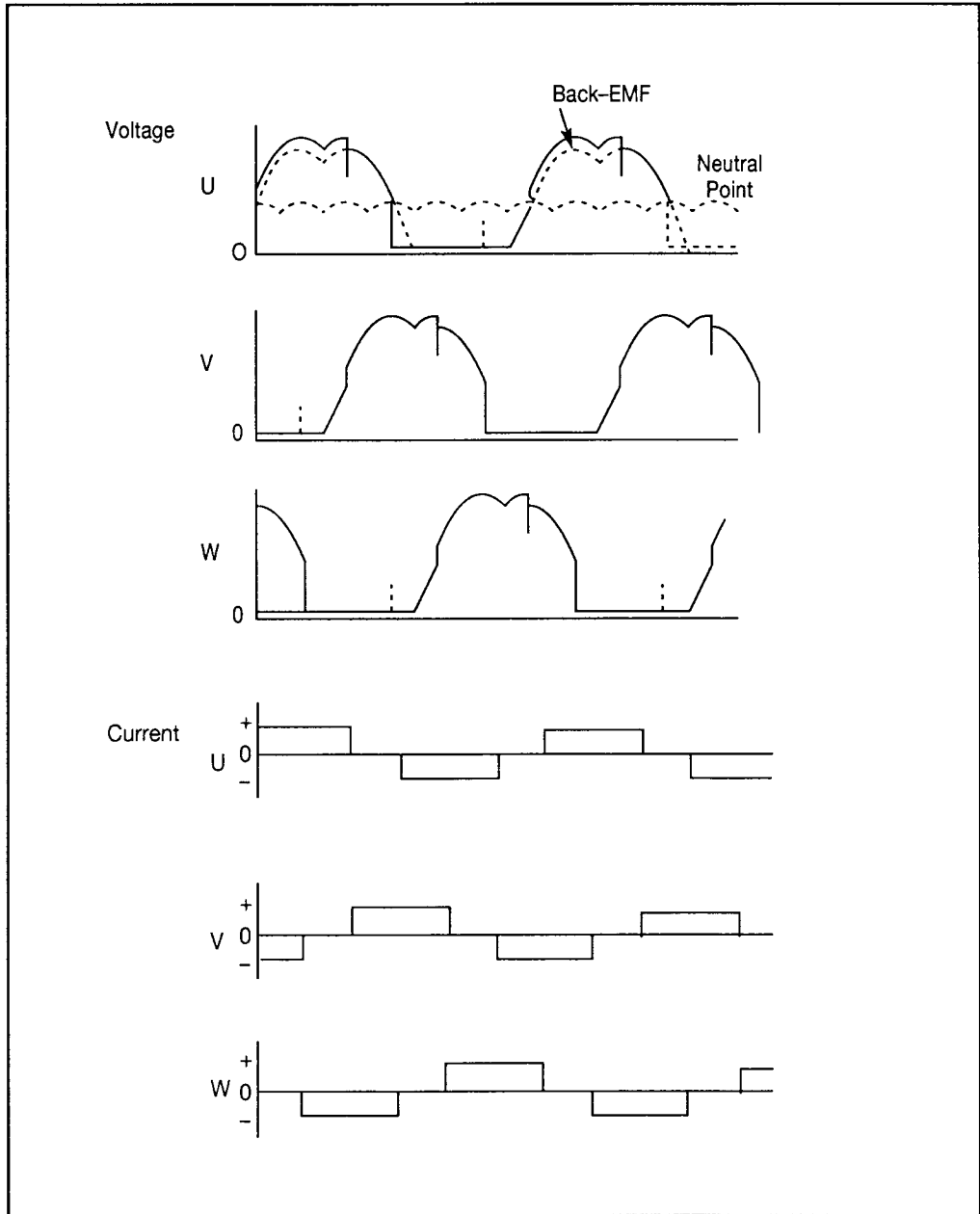

Absolute Maximum Ratings ( $T_a = 25^\circ\text{C}$ )

Item	Symbol	Rating	Unit	Notes
Power supply voltage	$V_{CC}$	+15	V	1
Input voltage	$V_{iN}$	$V_{CC}$	V	2
Output current	$I_O$	+2	A	3
Power dissipation	$P_T$	5	W	4
Junction temperature	$T_j$	+150	$^\circ\text{C}$	5
Storage temperature	$T_{stg}$	-55 to +125	$^\circ\text{C}$	

The absolute maximum ratings are limiting values, to be applied individually, beyond which the device may be permanently damaged. Functional operation under any of these conditions is not guaranteed. Exposing a circuit to its absolute maximum rating for extended periods of time may affect the device's reliability.

- Notes: 1. Operating voltage range is 10.2 V to 13.8 V.  
 2. Applied to CE, MTRON, CNTSEL, DSEL 1 and DSEL2 inputs.  
 3. ASO of upper and lower power transistors are shown below.  
 Operating locus must be within the ASO.

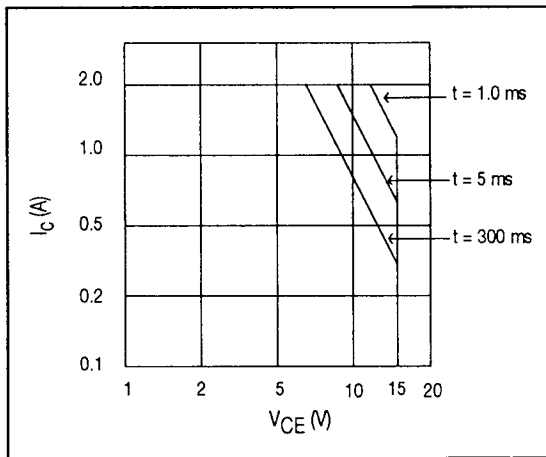

Figure 3 ASO of Output Stages

4. Value at  $T_C = 115^\circ\text{C}$   
 Thermal resistance is shown below.  
 $\theta_{j-c} \leq 7^\circ\text{C/W}$ ,  $\theta_{j-a} \leq 15^\circ\text{C/W}$  (Using Fe board),  $\theta_{j-a} \leq 62^\circ\text{C/W}$  (Using glass epoxide board)  
 5. Operating junction temperature is  $T_{jop} = 0^\circ\text{C}$  to  $+125^\circ\text{C}$



# HA13481S

Electrical Characteristics (Ta = 25°C, V<sub>CC</sub> = 12 V)

Block	Item	Symbol	Min	Typ	Max	Unit	Test conditions	Applicable Terminal	Notes	
Total	Quiescent current	I <sub>CC1</sub>	—	25	38	mA	Pin 10 = 0.0 V	19		
		I <sub>CC2</sub>	—	—	4.0		Pin 10 = 5.0 V			
CE	Input low voltage	V <sub>IL1</sub>	—	—	0.8	V	Enable	10		
	Input high voltage	V <sub>IH1</sub>	2.0	—	—		Disable			
	Input low current	I <sub>IL1</sub>	—	—	±100		Pin 10 = 0.0 V			
	Input high current	I <sub>IH1</sub>	—	—	±100		Pin 10 = 5.5 V			
Motor on	Input low voltage	V <sub>IL2</sub>	—	—	0.8	V	Motor on	9		
	Input high voltage	V <sub>IH2</sub>	2.0	—	—		Motor off			
	Input low current	I <sub>IL1</sub>	—	—	±100		Pin 9 = 0.0 V			
	Input high current	I <sub>IH1</sub>	—	—	±100		Pin 9 = 5.5 V			
Output amp.	Leak current	I <sub>CER1</sub>	—	—	2.0	mA	V <sub>CE</sub> = 15 V	16,17,18		
	Saturation voltage	V <sub>sat1</sub>	—	—	1.2		I <sub>O</sub> = 0.3 A			
		V <sub>sat2</sub>	—	—	2.0		I <sub>O</sub> = 1.0 A			
		V <sub>sat3</sub>	—	—	3.0		I <sub>O</sub> = 1.5 A			
	Current limiter	Ref. voltage	V <sub>OCL</sub>	V <sub>CLREF</sub> -25	V <sub>CLREF</sub> ±0		V <sub>CLREF</sub> +25			mV
Input current		I <sub>ICL</sub>	—	—	±5	μA				
B-EMF detector	Min. input sensitivity	V <sub>min1</sub>	70	100	130	mV <sub>P-P</sub>	Pin 21 = 4.2 V	21,23,24, 25,26		
Start-up circuit	OSC	Threshold voltage	V <sub>th1</sub>	3.3	3.5	3.7	V		22	3
		Threshold voltage	V <sub>th2</sub>	0.3	0.5	0.7				
		Sink current	I <sub>ts</sub>	40	55	80				
	Start-up monitor	Leak current	I <sub>CER2</sub>	—	—	±100	μA	V <sub>CE</sub> = 15 V	12	4
		Low voltage	V <sub>OL2</sub>	—	—	0.4				
Running communication	Min. input sensitivity	V <sub>min2</sub>	20	—	—	mV <sub>P-P</sub>	Pin 21 = 2.8 V	16,17, 18,21	6	
Control amp.	Gain	G <sub>ctl</sub>	-8	-6	-4	dB			2,15	
	Internal reference	V <sub>ref1</sub>	0.9	1.0	1.1					V
Oscillator	Frequency error	f <sub>err</sub>	—	—	±0.1	%	X'tal	5,6	7	
	Operating frequency	f <sub>osc2</sub>	—	—	8	MHz				
Zero-cross detector	Min. input sensitivity	V <sub>min3</sub>	500	—	—	mV <sub>P-P</sub>	Pin 21 = 4.2V	18,21		
Divider select 1	Input low voltage	V <sub>IL3</sub>	—	—	1.0	V	DIV. rate = 1/2	4		
	Input middle voltage	V <sub>IM3</sub>	2.0	—	3.1		DIV. rate = 1/4			
	Input high voltage	V <sub>IH3</sub>	3.9	—	—		DIV. rate = 1/6			
	Input low current	I <sub>IL3</sub>	-150	-105	-75		μA			Pin 4 = 0.0 V
	Input high current	I <sub>IH3</sub>	95	135	190					Pin 4 = 5.5 V





Electrical Characteristics (Ta = 25°C, V<sub>CC</sub> = 12 V)

Block	Item	Symbol	Min	Typ	Max	Unit	Test conditions	Appli- cable Terminal	Note
Divider select 2	Input low voltage	V <sub>IL4</sub>	—	—	1.0	V	DIV. rate = 1/643	3	7
	Input middle voltage	V <sub>IM4</sub>	2.0	—	3.1		DIV. rate = 1/32		
	Input high voltage	V <sub>IH4</sub>	3.9	—	—		DIV. rate = 1/16		
	Input low current	I <sub>IL4</sub>	-150	-105	-75	μA	Pin 3 = 0.0 V		
	Input high current	I <sub>IH4</sub>	95	135	190		Pin 3 = 5.5 V		
Count number select	Input low voltage	V <sub>IL5</sub>	—	—	1.0	V	Discri- count number	8	7
	Input middle voltage	V <sub>IM5</sub>	2.0	—	3.1		2084		
	Input high voltage	V <sub>IH5</sub>	3.9	—	—		2605		
	Input low current	I <sub>IL5</sub>	-150	-105	-75	μA	Pin 8 = 0.0 V		
	Input high current	I <sub>IH5</sub>	95	135	190		Pin 8 = 5.5 V		
Charge pump	R1 set-up voltage	V <sub>ref2</sub>	0.95	1.05	1.15	V	R <sub>1a</sub> + R <sub>1b</sub>	1	
	Charge current	I <sub>CH</sub>	44	52	61	μA	= 5.0 kΩ		
	Discharge current	I <sub>DIS</sub>	44	52	61		Pin 2 = 1.0 V	2	
	Leak current	I <sub>CER4</sub>	—	—	±50	nA	Pin 2 = 1.0 V		
	Current ratio	I <sub>rat</sub>	0.9	1.0	1.1	—	I <sub>rat</sub> = I <sub>CH</sub> /I <sub>DIS</sub>		
Ready	Output high voltage	V <sub>OH1</sub>	3.8	4.2	4.6	V	I <sub>O</sub> = 1.0 mA	11	5
	Output low voltage	V <sub>OL1</sub>	—	—	0.4		I <sub>O</sub> = 1.0 mA		
LVI	Recovery voltage	V <sub>LVI</sub>	—	—	8.0	V			
OSTSD	Operating temperature	T <sub>TSD</sub>	125	150	—	°C			6
	Hysteresis temperature	T <sub>hys</sub>	—	25	—				

- Notes: 1. Sum of upper and lower saturation voltage.  
2. Symbol "V<sub>CLREF</sub>" denotes the applied voltage at pin 11, and "V<sub>OCL</sub>" is measured from TAB (GND) to pin 15.  
3. See timing chart.  
4. This terminal is open collector output.  
5. See figure 4.  
6. Design guide only  
7. The maximum frequency, selecting the combination DSELZ = H and CNTSEL = H, must be less than 4 MHz.

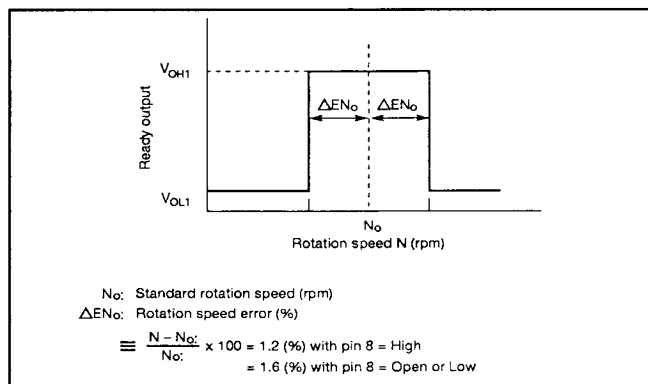

Figure 4 Operation of Ready Circuit



References

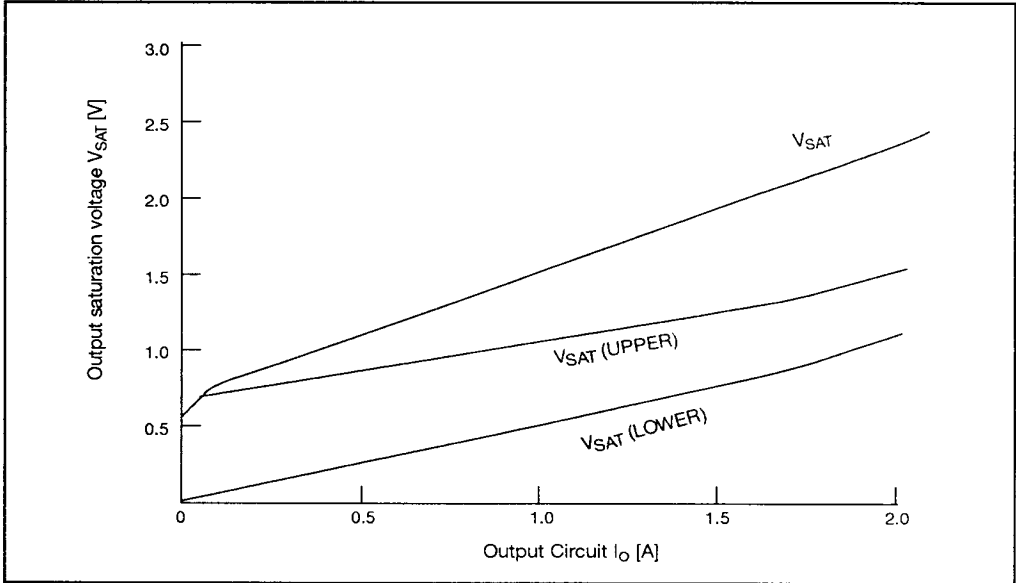

Figure 5  $V_{sat}$  vs  $I_o$

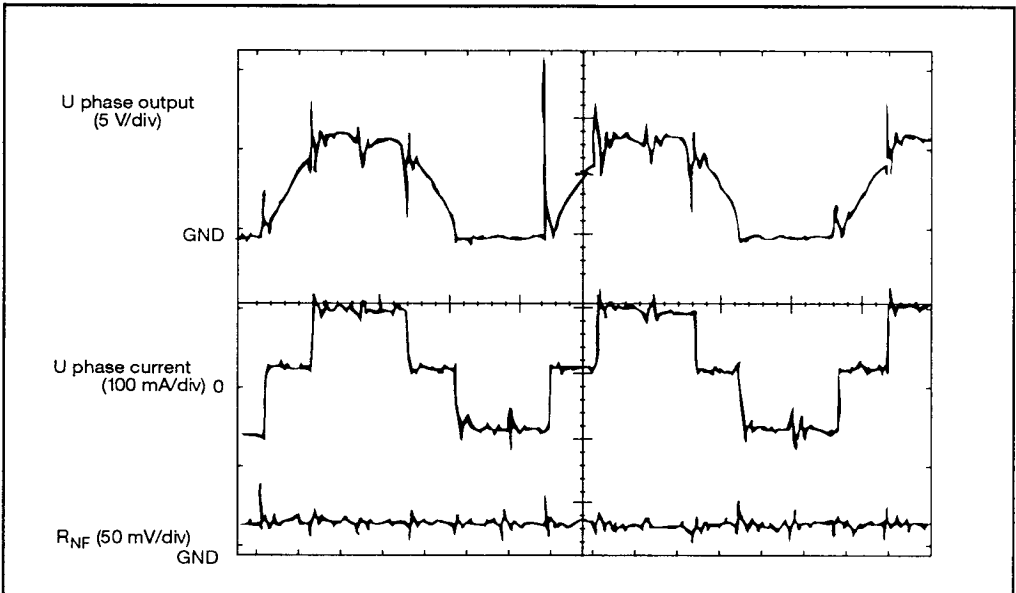

Figure 6 Waveform on Actual Application (3.5" 8 poles motor)

