

HDSP-2301

HDSP-2302

HDSP-2303

Four Character 5.0 mm (0.20 inch)
5 x 7 Alphanumeric Displays

Data Sheet

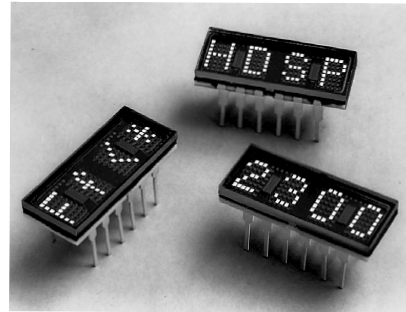

Description

The HDSP-2301/-2302/-2303 series of displays are 5.0 mm (0.20 inch) 5 x 7 LED arrays for display of alphanumeric information. These devices are available in yellow, high efficiency red, and high performance green. Each four character cluster is contained in a 12 pin dual-in-line package. An on-board SIPO (Serial-In-Parallel-Out) 7-bit shift register associated with each digit controls constant current LED row drivers. Full character display is achieved by external column strobing.

Features

- Integrated shift registers with constant current drivers
- Compact ceramic package
- Wide viewing angle
- End stackable four character package
- TTL compatible
- 5 x 7 LED matrix displays full ASCII set
- Categorized for luminous intensity
- HDSP-2301/2303 categorized for color

Applications

- Avionics
- Business machines
- Medical instruments
- Portable data entry devices

Devices

Yellow	High Efficiency Red	Green
HDSP-2301	HDSP-2302	HDSP-2303

Package Dimensions

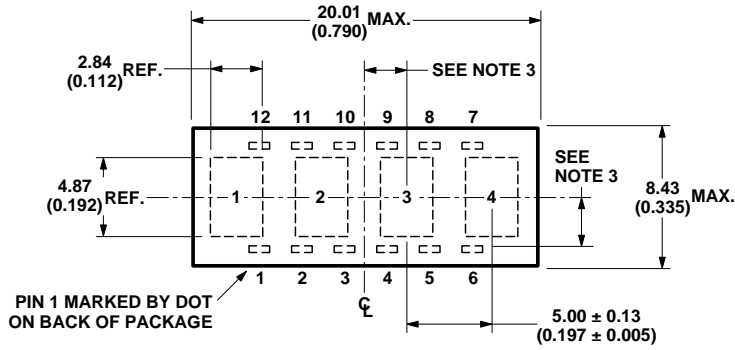

PIN	FUNCTION	PIN	FUNCTION
1	COLUMN 1	7	DATA OUT
2	COLUMN 2	8	V _B
3	COLUMN 3	9	V _{CC}
4	COLUMN 4	10	CLOCK
5	COLUMN 5	11	GROUND
6	INT. CONNECT*	12	DATA IN

*DO NOT CONNECT OR USE

NOTES:

1. DIMENSIONS IN MILLIMETERS (INCHES).
2. UNLESS OTHERWISE SPECIFIED, THE TOLERANCE ON ALL DIMENSIONS IS ± 0.38 mm (± 0.015 ").
3. CHARACTERS ARE CENTERED WITH RESPECT TO LEADS WITHIN ± 0.13 mm (± 0.005 ").

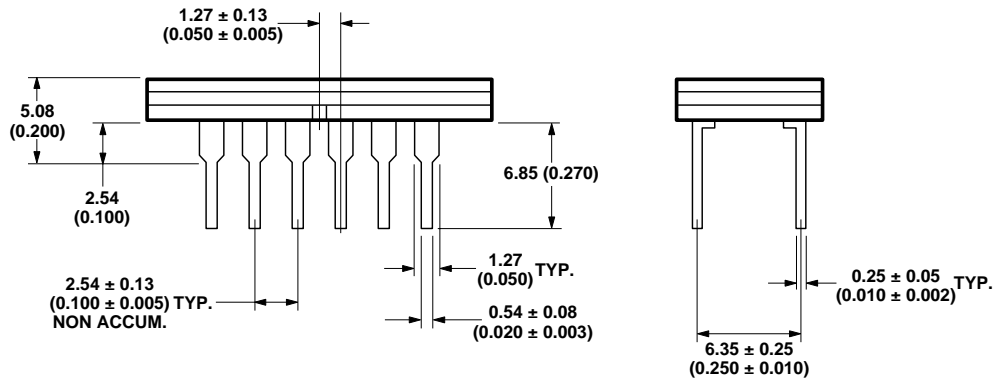

Absolute Maximum Ratings (HDSP-2301/-2302/-2303)

Supply Voltage, V _{CC} to Ground	-0.5 V to 6.0 V
Inputs, Data Out and V _B	-0.5 V to V _{CC}
Column Input Voltage, V _{COL}	-0.5 V to +6.0 V
Free Air Operating Temperature Range, T _A ^[1,2]	-20°C to +85°C
Storage Temperature Range, T _S	-55°C to +100°C
Maximum Allowable Package Dissipation at T _A = 25°C ^[1,2,3]	
HDSP-2301/-2302/-2303	1.46 Watts
Maximum Solder Temperature 1.59 mm (0.63")	
Below Seating Plane t < 5 sec	260°C

Recommended Operating Conditions (HDSP-2301/-2302/-2303)

Parameter	Symbol	Min.	Nom.	Max.	Units	Fig.
Supply Voltage	V _{CC}	4.75	5.0	5.25	V	
Data Out Current, Low State	I _{OL}			1.6	mA	
Data Out Current, High State	I _{OH}			-0.5	mA	
Column Input Voltage, Column On HDSP-2301/-2302/-2303	V _{COL}	2.75		3.5	V	4
Setup Time	t _{setup}	70	45		ns	1
Hold Time	t _{hold}	30	0		ns	1
Width of Clock	t _{w(Clock)}	75			ns	1
Clock Frequency	f _{clock}	0		3	MHz	1
Clock Transition Time	t _{THL}			200	ns	1
Free Air Operating Temperature Range ^[1,2]	T _A	-20		85	°C	2

Electrical Characteristics over Operating Temperature Range
(Unless otherwise specified)

Yellow HDSP-2301/High Efficiency Red HDSP-2302/ High Performance Green HDSP-2303

Description		Symbol	Test Conditions	Min.	Typ.*	Max.	Units	Fig.
Supply Current		I _{CC}	V _{CC} = 5.25 V V _{CLOCK} = V _{DATA} = 2.4 V All SR Stages = Logical 1	V _B = 0.4 V	45	60	mA	
				V _B = 2.4 V	73	95	mA	
Column Current at any Column Input		I _{COL}	V _{CC} = 5.25 V V _{COL} = 3.5 V All SR Stages = Logical 1	V _B = 0.4 V		500	μA	
Column Current at any Column Input		I _{COL}		V _B = 2.4 V	380	520	mA	
V _B , Clock or Data Input Threshold High		V _{IH}	V _{CC} = V _{COL} = 4.75 V	2.0			V	4
V _B , Clock or Data Input Threshold Low		V _{IL}				0.8	V	
Input Current Logical 1	V _B , Clock	I _{IH}	V _{CC} = 5.25 V, V _{IH} = 2.4 V		20	80	μA	
	Data In	I _{IH}			10	40	μA	
Input Current Logical 0	V _B , Clock	I _{IL}	V _{CC} = 5.25 V, V _{IL} = 0.4V		-500	-800	μA	
	Data In	I _{IL}			-250	-400	μA	
Data Out Voltage		V _{OH}	V _{CC} = 4.75 V, I _{OH} = -0.5 mA, I _{COL} = 0 mA	2.4	3.4		V	
		V _{OL}	V _{CC} = 4.75 V, I _{OL} = 1.6 mA, I _{COL} = 0 mA		0.2	0.4	V	
Power Dissipation Per Package**		P _D	V _{CC} = 5.0 V, V _{COL} = 3.5 V, 17.5% DF 15 LEDs on per character, V _B = 2.4 V		0.78		W	2
Thermal Resistance IC Junction-to-Case		R _{θJ-C}			25		°C/W/Device	2

*All typical values specified at V_{CC} = 5.0 V and T_A = 25°C unless otherwise noted.

**Power dissipation per package with four characters illuminated.

Notes:

1. Operation above 85°C ambient is possible provided the following conditions are met. The junction temperature should not exceed 125°C T_j and the case temperature (as measured at pin 1 or the back of the display) should not exceed 100°C T_c.
2. The HDSP-2301/-2302/-2303 should be derated linearly above 37°C at 16.7 mW/°C. This derating is based on a device mounted in a socket having a thermal resistance from case to ambient at 35°C/W per device. See Figure 2 for power deratings based on a lower thermal resistance.
3. Maximum allowable dissipation is derived from V_{CC} = 5.25 V, V_B = 2.4 V, V_{COL} = 3.5 V 20 LEDs on per character, 20% DF.

Optical Characteristics

Yellow HDSP-2301

Description	Symbol	Test Conditions	Min.	Typ.*	Max.	Units	Fig.
Peak Luminous Intensity per LED ^[4,8] (Character Average)	I_{VPeak}	$V_{CC} = 5.0\text{ V}$, $V_{COL} = 3.5\text{ V}$ $T_i = 25^\circ\text{C}^{[6]}$, $V_B = 2.4\text{ V}$	650	1140		μcd	3
Peak Wavelength	λ_{PEAK}			583		nm	
Dominant Wavelength ^[5,7]	λ_d			585		nm	

High Efficiency Red HDSP-2302

Description	Symbol	Test Conditions	Min.	Typ.*	Max.	Units	Fig.
Peak Luminous Intensity per LED ^[4,8] (Character Average)	I_{VPeak}	$V_{CC} = 5.0\text{ V}$, $V_{COL} = 3.5\text{ V}$ $T_i = 25^\circ\text{C}^{[6]}$, $V_B = 2.4\text{ V}$	650	1430		μcd	3
Peak Wavelength	λ_{PEAK}			635		nm	
Dominant Wavelength ^[7]	λ_d			626		nm	

High Performance Green HDSP-2303

Description	Symbol	Test Conditions	Min.	Typ.*	Max.	Units	Fig.
Peak Luminous Intensity per LED ^[4,8] (Character Average)	I_{VPeak}	$V_{CC} = 5.0\text{ V}$, $V_{COL} = 3.5\text{ V}$ $T_i = 25^\circ\text{C}^{[6]}$, $V_B = 2.4\text{ V}$	1280	2410		μcd	3
Peak Wavelength	λ_{PEAK}			568		nm	
Dominant Wavelength ^[5,7]	λ_d			574		nm	

*All typical values specified at $V_{CC} = 5.0\text{ V}$ and $T_A = 25^\circ\text{C}$ unless otherwise noted.

**Power dissipation per package with four characters illuminated.

Notes:

- The characters are categorized for luminous intensity with the intensity category designated by a letter code on the bottom of the package.
- The HDSP-2301/-2303 are categorized for color with the color category designated by a number code on the bottom of the package.
- T_i refers to the initial case temperature of the device immediately prior to the light measurement.
- Dominant wavelength λ_d , is derived from the CIE chromaticity diagram, and represents the single wavelength which defines the color of the device.
- The luminous sterance of the LED may be calculated using the following relationships:

$$L_v (\text{cd/m}^2) = I_v (\text{Candela})/A (\text{Metre})^2$$

$$L_v (\text{Footlamberts}) = \pi I_v (\text{Candela})/A (\text{Foot})^2$$

$$A = 5.3 \times 10^{-8} \text{ M}^2 = 5.8 \times 10^{-7} (\text{Foot})^2$$

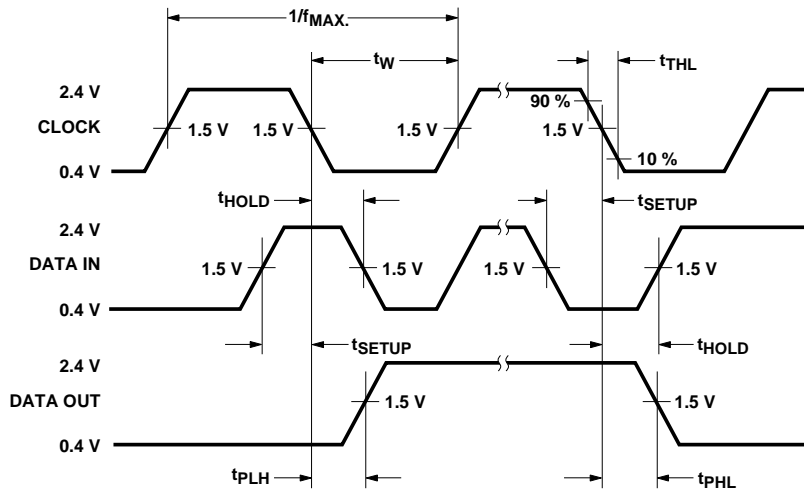

PARAMETER	CONDITION	MIN.	TYP.	MAX.	UNITS
f_{CLOCK} CLOCK RATE				3	MHz
$t_{\text{PLH}}, t_{\text{PHL}}$ PROPAGATION DELAY CLOCK TO DATA OUT	$C_L = 15 \text{ pF}$ $R_L = 2.4 \text{ K}\Omega$			125	ns

Figure 1. Switching Characteristics HDSP-2301/-2302/-2303 ($T_A = -20^\circ\text{C}$ to $+85^\circ\text{C}$).

HDSP-2301/-2302/-2303

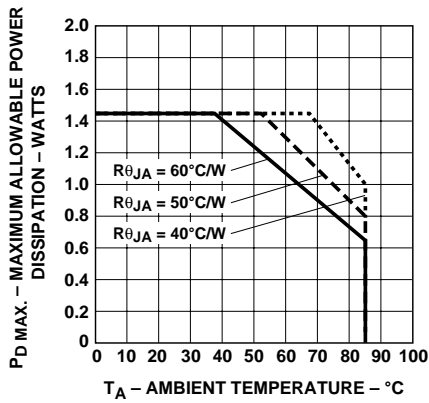

Figure 2. Maximum Allowable Power Dissipation vs. Temperature.

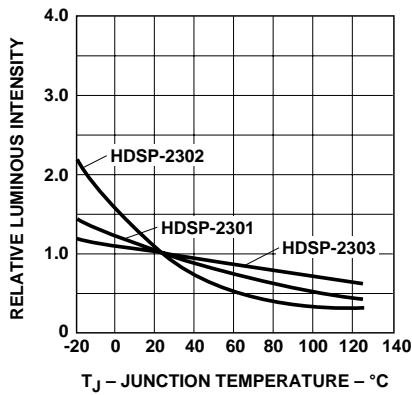

Figure 3. Relative Luminous Intensity vs. Temperature.

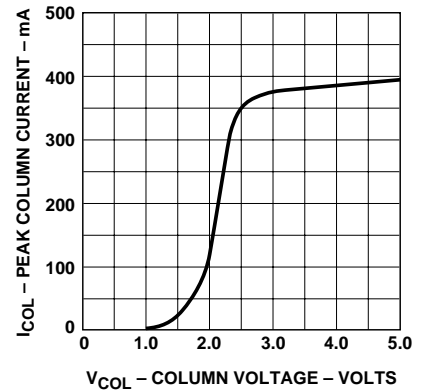

Figure 4. Peak Column Current vs. Column Voltage.

Electrical Description

The HDSP-230X series of four character alphanumeric displays have been designed to allow the user maximum flexibility in interface electronics design. Each four character display module features Data In and Data Out terminals arrayed for easy PC board interconnection. Data Out represents the output of the 7th bit of digit number 4 shift register. Shift register clocking occurs on the high to low transition of the Clock input. The like columns of each character in a display cluster are tied to a single pin. Figure 5 is the block diagram for the displays. High true data in the shift register enables the output current mirror driver stage associated with each row of LEDs in the 5 x 7 diode array.

The TTL compatible V_B input may either be tied to V_{CC} for maximum display intensity or pulse width modulated to achieve intensity control and reduction in power consumption.

The normal mode of operation input data for digit 4, column 1,

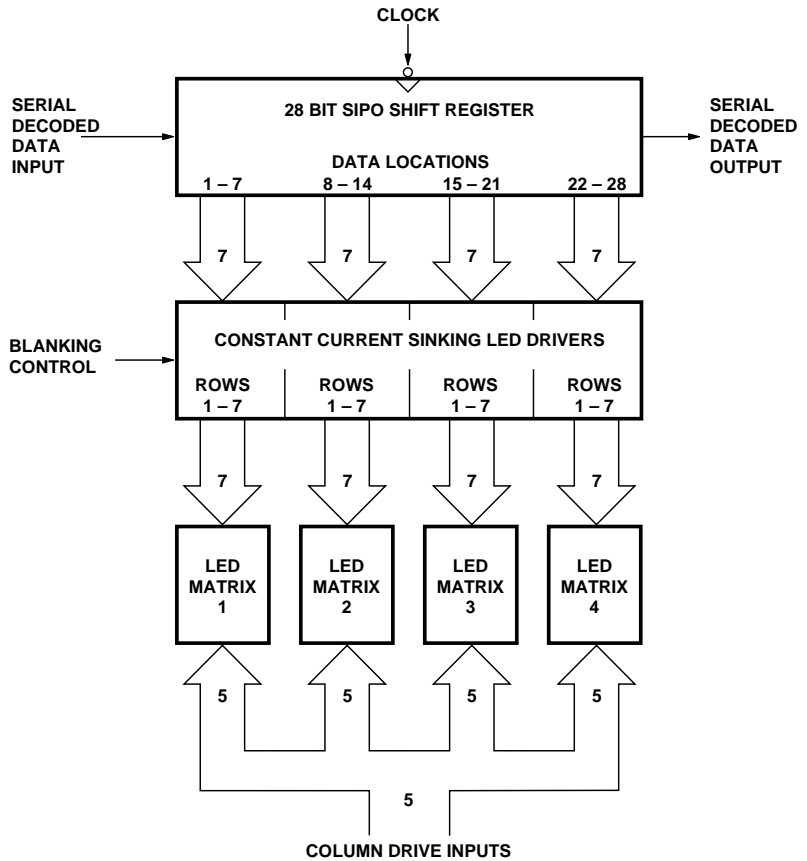

Figure 5. Block Diagram of HDSP-2301/-2302/-2303.

Display Color	Ambient Lighting		
	Dim	Moderate	Bright
HDSP-2301 (Yellow)	Panelgraphic Yellow 27 Chequers Amber 107	Polaroid HNC37 3M Light Control Film Panelgraphic Gray 10	Polaroid HNC10
HDSP-2302 (HER)	Panelgraphic Ruby Red 60 Chequers Red 112	Chequers Grey 105	
HDSP-2303 (HP Green)	Panelgraphic Green 48 Chequers Green 107		

Figure 6. Contrast Enhancement Filters.

is loaded into the 7 on-board shift register locations 1 through 7. Column 1 data for digits 3, 2, and 1 is similarly shifted into the display shift register locations. The column 1 input is now enabled for an appropriate period of time, T. A similar process is repeated for columns 2, 3, 4, and 5. If the time necessary to decode and load data into the shift register is t, then with five columns, each column of the display is operating at a duty factor of:

$$D.F. = \frac{T}{5(t + T)}$$

The time frame, t + T, allotted to each column of the display is generally chosen to provide the maximum duty factor consistent with the minimum refresh rate necessary to achieve a flicker free display. For most strobed display systems, each column of the display should be refreshed (turned on) at a minimum rate of 100 times per second.

With columns to be addressed, this refresh rate then gives a value for the time t + T of:

$$1/[5 \times (100)] = 2 \text{ msec}$$

If the device is operated at 3.0 MHz clock rate maximum, it is possible to maintain t < T. For short display strings, the duty factor will then approach 20%.

For further applications information, refer to Agilent Application Note 1016.

Mechanical and Thermal Considerations

The HDSP-2301/-2302/-2303 are available in standard ceramic dual-in-line packages. They are designed for plugging into sockets or soldering into PC boards. The packages may be horizontally or vertically stacked for character arrays of any desired size. The HDSP-2301/-2302/-2303 utilize a high output current IC to provide excellent readability in bright ambient lighting. Full power operation ($V_{CC} = 5.25 \text{ V}$, $V_B = 2.4 \text{ V}$, $V_{COL} = 3.5 \text{ V}$) with worst case thermal resistance from IC junction to ambient of $60^\circ\text{C}/\text{watt}/\text{device}$ is possible up to ambient temperature of 37°C . For operation above 37°C , the maximum device dissipation should be derated linearly at $16.7 \text{ mW}/^\circ\text{C}$ (see Figure 2). With an improved thermal design, operation at higher ambient temperatures without derating is possible.

Power derating for this family of displays can be achieved in several ways. The power supply voltage can be lowered to a minimum of 4.75 V. Column Input Voltage, V_{COL} , can be decreased to the recommended minimum value of 2.75 V for the HDSP-2301/-2302/-2303. Also, the average drive current can be decreased through pulse width modulation of V_B .

The HDSP-2301/-2302/-2303 displays have glass windows. A front panel contrast enhancement filter is desirable in most actual display applications. Some suggested filter materials are provided in Figure 6. Additional information on filtering and contrast enhancement can be found in Agilent Application Note 1015.

For more information on soldering and post-solder cleaning, please see Application Note 1027, Soldering LED Components.

For product information and a complete list of distributors, please go to our website: www.avagotech.com

Avago, Avago Technologies, and the A logo are trademarks of Avago Technologies Limited in the United States and other countries.
Data subject to change. Copyright © 2007 Avago Technologies Limited. All rights reserved. Obsoletes 5953-7749E
5966-2487E November 27, 2007

