

AN INTRODUCTION TO THE L296 POWER SWITCHING REGULATOR

A cost-effective replacement for costly hybrids, the SGS L296 Power Switching Regulator delivers 4A at a voltage from 5.1V to 40V and includes many popular supply features. This note explains how the device operates, presents typical application circuits and offers useful rules for the choice of external components.

Fig. 1 -- A simple, compact reliable and inexpensive 4A switching supply can be built around the L296 Power Switching Regulator. Many of the components shown here can be omitted in simpler configurations.

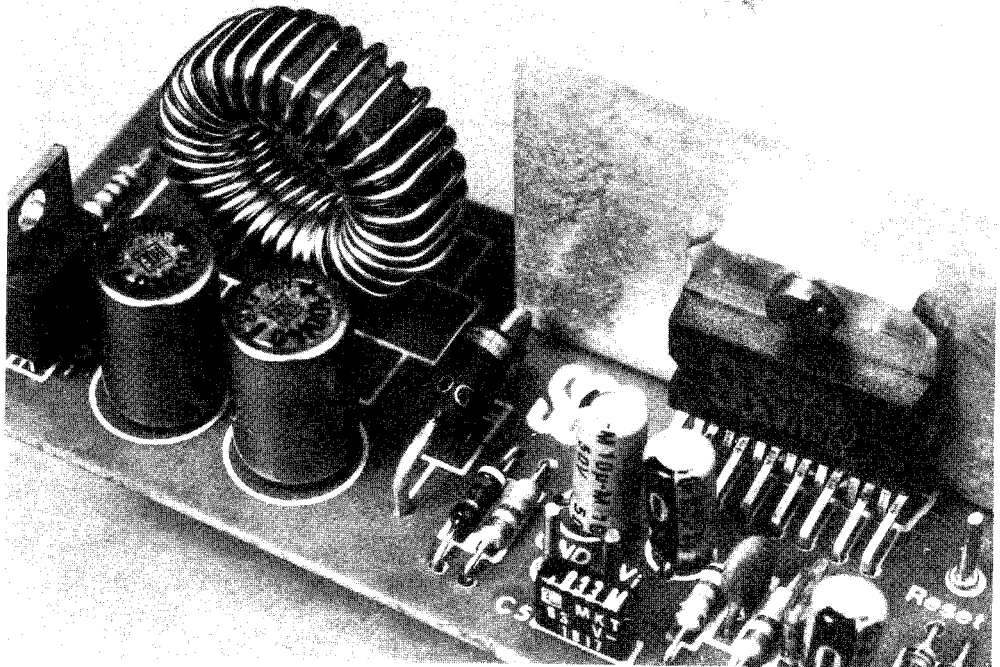

Integrating a full-feature, high-power switching regulator in a single plastic-packaged chip, the SGS L296 Power Switching Regulator offers power supply designers a new alternative to costly hybrids or controller/transistor combinations. Housed in the Multiwatt®-15 power package, it delivers up to 4A at 5.1V to 40V and includes a comprehensive array of support and protection features.

Keeping the application cost to a minimum, the L296 is designed to minimize the cost of external component support without sacrificing performance. To reduce the size and cost of the output LC filter — a determining factor in switching regulators — the L296 is capable of operating efficiently at switching frequencies up to 200 kHz; a special output stage design keeps the switching times to around 100 ns.

Further reduction in cost has been achieved by integrating as much as possible on the chip. All the standard power supply features are included and it even incorporates the load current sense resistor — a 10 mΩ metal track.

Features of the L296 include soft start, programmable current limiting, thermal shutdown, remote inhibit, a reset output for microprocessors and a voltage sense/SCR drive circuit for crowbar over-voltage protection with an external SCR. All of these features are implemented so that components can be omitted in simpler configurations when the function is not needed.

SOFT START slows down the risetime of the output voltage when power is applied, and also when the circuit restarts after an inhibit. It thus eliminates the power-on transients which can damage voltage-sensitive components, or affect their reliability. An external capacitor sets the risetime so that it can be tailored to suit specific requirements.

CURRENT LIMITING protects the L296 from short circuits of the load. Since the limit threshold is adjustable it can also be used to protect the load itself from fault conditions. The limit threshold can be varied from 0.5A to 5A with an external resistor. And if this resistor is omitted, the L296 assumes a limit of 5A, thus protecting itself.

Useful in microprocessor systems, the RESET CIRCUIT provides a logic signal to indicate when the output is above a preset threshold. The reset threshold can be adjusted externally and the reset signal is delayed to prevent false starts.

Coupled to the reset input of a microprocessor, the reset signal inhibits operation whenever the supply is unsafe. It can also be used for applications such as write protection in non-volatile memory.

The OVERVOLTAGE PROTECTION circuit is of the crowbar type and operates with an external SCR connected across the output. It provides direct gate drive for the SCR and has an external voltage sense input so that either the input or output voltage can be monitored.

Fig. 2 - In addition to the basic regulation loop, the L296 includes useful features such as current limiting and a reset circuit which reduce the amount of support circuitry required in typical applications.

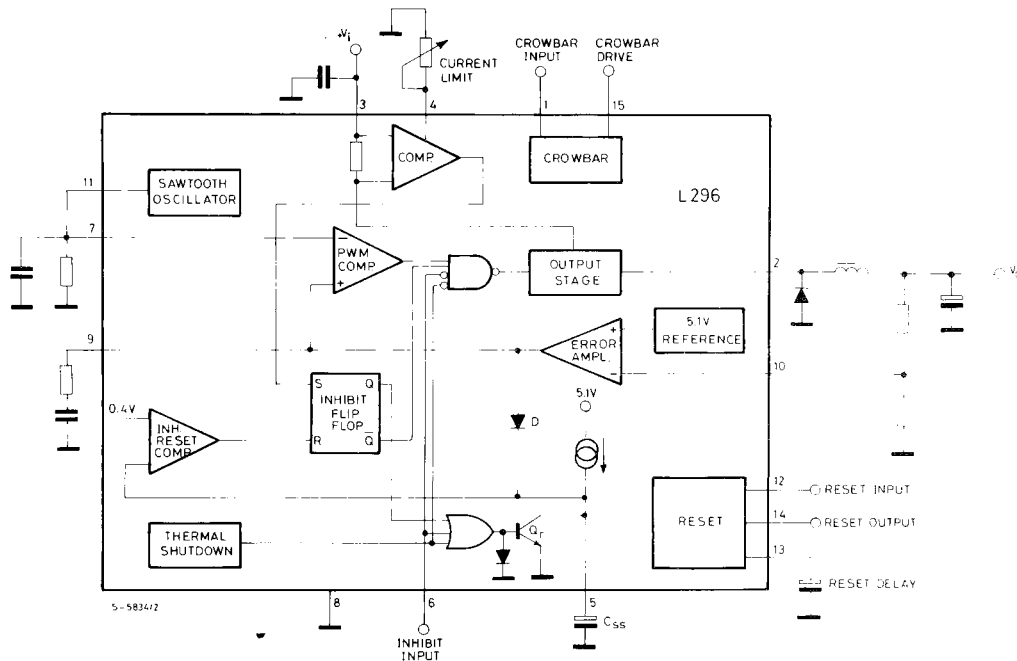

THERMAL SHUTDOWN protects the device in overload conditions by disabling the output stage when the junction temperature exceeds 150°C; it has hysteresis to prevent unstable conditions.

REMOTE INHIBIT is permitted by a TTL-compatible inhibit input which disables the L296. When the inhibit signal is removed the circuit restarts with the normal soft ramp. The inhibit input is useful for both remote control and supply sequencing.

HOW IT WORKS

The L296's main regulation loop can be seen in the simplified block diagram, figure 2, it consists of a 5.1V reference, loop error amplifier, PWM modulator (sawtooth oscillator plus comparator), power stage and an external LC filter.

Voltage feedback from the output is compared with the 5.1V reference in the error amplifier. The output of this amplifier sets the threshold of the PWM comparator and thus controls the duty cycle of the switching pulses. These pulses drive the output stage, producing the desired output voltage

with the help of the LC filter. If the output is connected to the feedback point directly the regulated output voltage is 5.1V; a divider is added to the feedback loop to produce higher voltages. The loop gain characteristics can be modified by the external RC network R_gC_g to give the required stability, ripple rejection at twice the mains frequency and rejection of supply and load variations.

The output of the oscillator is not connected internally to the PWM comparator. This is done deliberately so that several L296s can be synchronized, avoiding intermodulation on the ground plane in multiple supplies.

SOFT START

Soft start is produced by the diode D, an external capacitor C_{SS} and a constant current source. When power is applied, after an inhibit or after the intervention of the current limiter, the voltage across C_{SS} is zero, clamping the error amplifier output to zero via the diode D. The capacitor is charged by the constant current generator, thereby allowing the error amplifier output — and hence the output voltage — to rise (figure 3).

Fig. 3 — When power is applied, or after an inhibit, the L296's output voltage rises slowly under control of the soft start clamp.

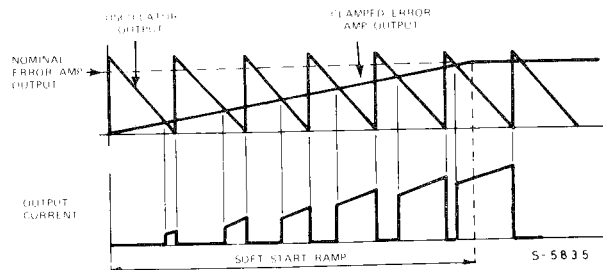
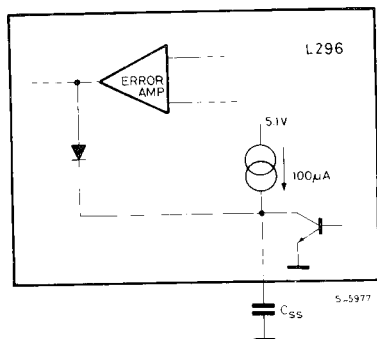

Fig. 4 — The soft start capacitor clamps the output of the L296's error amplifier and is charged by a 100 μ A current source.



The soft start risetime is set by the capacitor on pin 5. This capacitor must be in the range 1 μ F to 4.7 μ F. With the suggested value of 2.2 μ F the risetime is 100ms; the time for other values is easily calculated bearing in mind that the capacitor is charged by a 100 μ A source (figure 4).

Note that this capacitor also affects the average current in short circuit conditions.

CURRENT LIMITING

Current limiting is realized with two comparators, a flip-flop, an AND gate, an OR gate and the transistor Q_r . The first comparator compares the output current, sensed by an on-chip metal resistor, with the limit threshold preset by an external resistor.

As soon as the current tops the threshold, this comparator switches, setting the flip-flop which

disables the output stage and shorts the soft start capacitor via Qr.

A second comparator resets the flip flop when the voltage across C_{SS} has fallen below 0.4V, re-enabling the output stage. With the usual slow ramp, the output current rises again and if the cause of the excess current is still present the whole process is repeated.

This trigger-retry cycle continues until the fault condition is removed (figure 5). Thanks to the dead time and the soft start ramp the average current in this condition is very low.

A resistor connected to pin 4 sets the current limit threshold. If this resistor is omitted and pin 4 left open circuit, the limit threshold is 5A. The threshold can be varied from 0.5A to 4A. For a threshold of 2.5A the resistor is about 33k Ω .

Fig. 5 - Triggered when the output reaches an externally adjustable threshold, the current limiter operates in continual retry mode until the fault is removed.

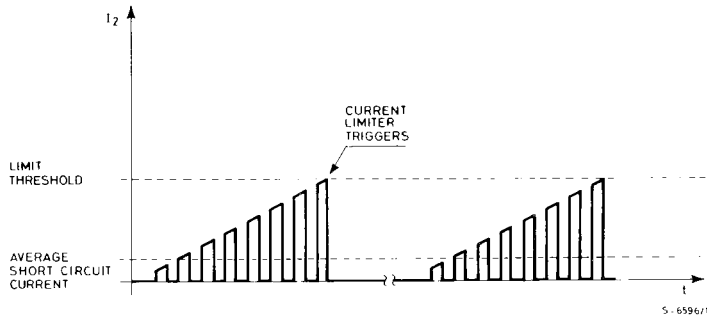

OUTPUT VOLTAGE PROGRAMMING

The output voltage can be varied from 5.1V to 40V and is set by the divider connected between the output and the feedback input.

The divider ratio is given by:

$$\frac{R6}{R7} = \frac{V_o - V_{ref}}{V_{ref}}$$

(V_{ref} is the reference voltage, nominally 5.1V). R7 should not be greater than 51k Ω or the feedback input leakage current will load the divider. For an output voltage of 5.1V the divider is omitted.

INHIBIT INPUT

The inhibit input, pin 6, is TTL, NMOS and CMOS compatible. It disables the L296 when high and must be connected to ground if not used. When the inhibit signal goes from high to low the circuit restarts softly. On the SGS evaluation board this input is tied to ground through a resistor so that the device will operate if no inhibit signal is provided. In real applications this resistor is not needed.

CROWBAR PROTECTION

The crowbar overvoltage protection block has two connections: a voltage sense input and an SCR gate drive output. The SCR is triggered when the voltage on the sense input exceeds the voltage reference by about 20%, i.e. the voltage sense input has a threshold of about 6V.

Normally the sense input is connected directly to the feedback point, pin 10. It can, however, be used to monitor the input voltage, adding a suitable voltage divider to set the threshold.

The gate drive output supplies up to 100 mA and connects directly to the gate of the SCR. The SCR must be able to withstand the peak discharge current of the output capacitor and the short circuit current of the device.

RESET CIRCUIT

The reset circuit has three connections: the reset signal output, the sense input and a connection for the capacitor that sets the delay.

The reset delay capacitor must be in the range 1 μ F to 4.7 μ F. A delay of about 100ms given by the recommended value of 2.2 μ F.

The sense input, pin 12, may be connected directly to the feedback point (pin 10) or, with a suitable divider, to the unregulated input (figure 6).

The internal threshold of the reset circuit is $V_{ref} - 100$ mV (roughly 5V). Therefore the divider for the second case is found from:

$$\frac{R1 + R2}{R2} = \frac{V_{i \min}}{V_{ref} - 100 \text{ mV}}$$

R2 should not exceed 200 k Ω .

The reset output is open collector and the maximum allowed collector current is 50 mA.

Fig. 6 - The reset circuit's sense input can be connected to the feedback point (a) or to the input via a divider (b) to raise the threshold.

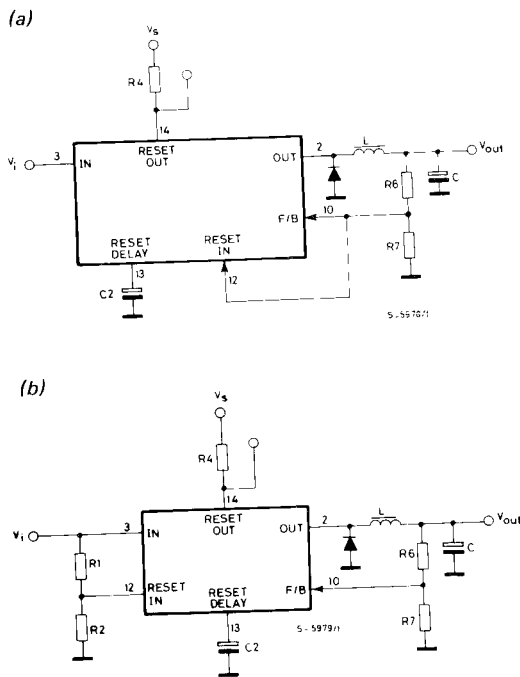

$$\text{Therefore } L = \frac{5(35-5)}{35 \times 100 \times 10^{-3} \times 150 \times 10^{-3}} \cong 300 \mu\text{H}$$

and

$$C = \frac{5(35-5)}{8 \times 300 \times 10^{-6} \times (100 \times 10^3)^2 \times 30 \times 10^{-3}} \cong 220 \mu\text{F}$$

In practice the ripple depends on the quality of the filter capacitor. With standard components the ripple will be roughly twice the value implied by this calculation. In this example the actual ripple is about 5 mV.

A multiple capacitor — two or more connected in parallel with a total capacity of C — is recommended. Smaller electrolytics have a lower inductance — important at high frequencies — and handle higher peak currents.

COMPENSATION AND STABILITY

The system is non linear because the output stage operates in switchmode. However, in certain conditions the system can be represented as linear blocks. Delays are introduced by the output stage which can contribute to instability of the system.

When the switching frequency is at least ten times greater than the frequency at which the open loop gain is unity, the system can be approximated to a linear system. The PWM block can then be characterized as a linear block with gain independent of frequency.

Compensating the system with a series RC network on the output of the error amplifier (pin 9), we obtain:

$$Z = \frac{1 + sRC}{sC}$$

Placing the zero introduced by the RC network at the resonance frequency of the LC output filter ($\omega_0 = 1/\sqrt{LC}$) we obtain the Bode plot shown in figure 7.

THE LC FILTER

The LC filter converts the pulse output of the L296's power stage into a continuous output voltage with a superimposed ripple, ΔV . The inductor ripple current determines the voltage ripple on the capacitor.

The ripple ΔI_L is generally chosen to be twice the minimum load current to avoid periods when the transistor and diode are both non-conducting.

The formulae used to calculate LC as a function of ΔI_L and ΔV are:

$$L = \frac{V_o (V_i - V_o)}{V_i f \Delta I_L}$$

$$C = \frac{V_o (V_i - V_o)}{8 L f^2 \Delta V}$$

For example, for the test circuit (figure 12) the LC filter was calculated from the following data:

$$\begin{aligned} V_i &= 35\text{V} & V_o &= 5\text{V} \\ \Delta I_L &= 150\text{mA} & f &= 100\text{kHz} \\ \Delta V &= 3\text{mV} \end{aligned}$$

Fig. 7 - Bode plot of the main regulation loop.

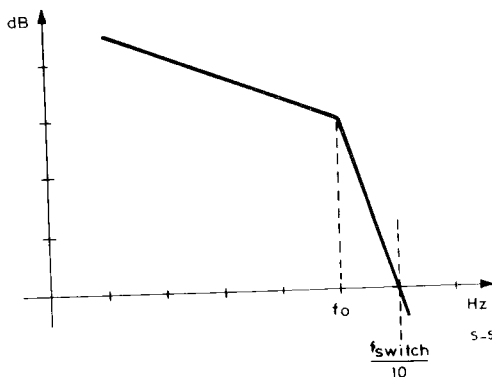

0 μ H

20 μ F

of the
s the
ed by
ripple

ted in
ecom-
induc-
handle

t stage
n con-
linear
t stage
system.

times
n loop
ed to a
charac-
ter of

network
(9), we

network
ut filter
own in

op.

Hz
5-5975/1

The slope when it crosses the frequency axis at 0 dB is roughly 40 dB/decade. In practice the LC filter contains parasitic elements which give a lower slope.

The series resistance of the capacitor (ESR) introduces a zero at high frequencies, guaranteeing stability of the system.

DIODE

The diode should be a fast type to avoid high current peaks in the output transistor. The choice is therefore between Schottky diodes and fast diodes with a t_{rr} of less than 35 ns.

The only significant difference is the lower forward voltage of Schottky diodes. At low output voltages - around 5V - a Schottky diode therefore improves the efficiency of the system.

SWITCHING FREQUENCY

The choice of switching frequency depends on the inductor chosen (a smaller inductor can be used at higher frequencies), the power dissipation and desired efficiency. It should not exceed 200 kHz or efficiency will be reduced; the lower limit is set only by the maximum acceptable dimensions of the output filter.

The chosen frequency is set by the RC network connected to pins 7 and 11 (OSC and SYNC). Suitable values can be found from the nomogram, figure 8. The capacitor must be in the range 1 nF - 3.3 nF and the resistor in the range 1 k Ω to 100 k Ω .

Fig. 8 - Use this nomogram to choose values for the oscillator components.

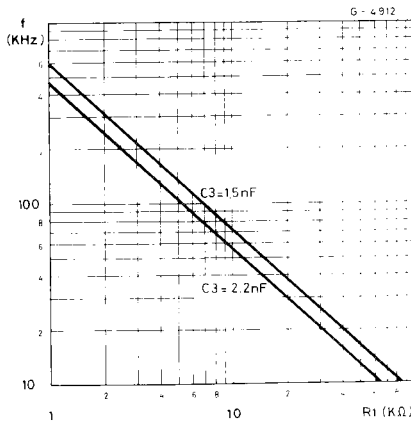

RFI/EMI SUPPRESSION

Electromagnetic interference generated by a high

current switching regulator can affect sensitive circuitry. Metal shielding of the regulator is the simple solution. Since the L296 circuit is very compact the board can be housed in the L296's heatsink.

EFFICIENCY

The efficiency of a complete regulator depends on many factors including the switching frequency, the recirculation diode, the input/output differential, and the output current.

In applications where very high efficiency is required, a lower switching frequency must be chosen. Efficiency is also improved by choosing an input voltage not too high.

SYNCHRONISATION

When several L296s are used in a multiple supply the switching frequencies should be synchronised.

This is done by connecting the SYNC pins together and omitting the oscillator components on all but the first device. The OSC pins of the subsequent devices are left open, as shown in figure 9.

Fig. 9 - In multiple supplies several L296s should be synchronized as shown here to avoid intermodulation.

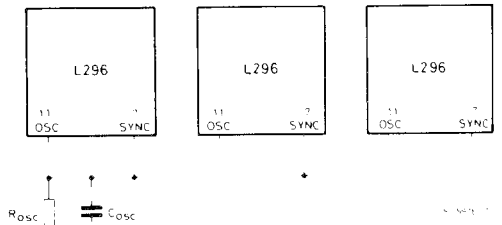

LAYOUT

In view of the high currents (5A peak) and fast switching times involved, care is necessary in the printed circuit layout to avoid problems. In particular, the tracks connecting the L296 output, recirculation diode and LC filter must be short to reduce voltage drop and avoid stray coupling.

It is also important to connect the input filter capacitor, the recirculation diode and output capacitor to the same ground point. A separate ground should be used for the signal processing circuit grounds, connected to the power ground at the negative output terminal.

To guarantee good load regulation the two sensing terminals, pin 8 and 10, should be connected directly to the load as shown in figure 10. The two

ten ohm resistors shown in this circuit are necessary to ensure that feedback will still be supplied to the L296 even when the sensing wires are disconnected.

Fig. 10 - When the load is some distance away this four wire connection ensures good regulation.

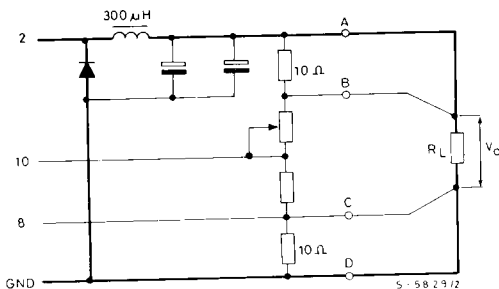

HEATSINK

The choice of heatsink depends on the power dissipated in the device and the desired operating junction temperature. Figure 11 shows the power dissipation derating curves for typical heatsinks.

Silicone grease is often used to improve the contact thermal resistance. The grease should not be too thick or viscous — the thermal resistance may be worsened or the tab deformed.

Care should also be taken when mounting the device on the heatsink. To avoid deforming the tab, which can affect reliability, the mounting screw should be tightened to roughly 8 kg/cm and the heatsink surface should have a planarity no

worse than 20 μm. A washer on the screw helps spread the load on the tab and minimize distortion.

Fig. 11 - These derating curves indicate maximum dissipation in L296 with various heatsink types.

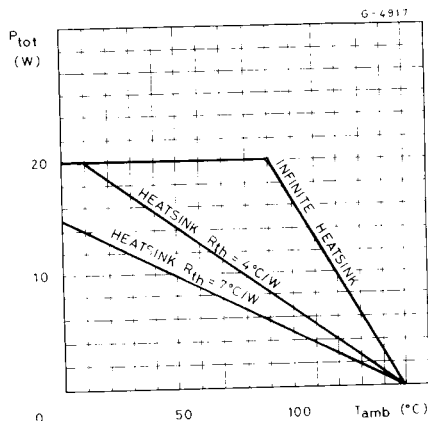

APPLICATION CIRCUITS

The standard evaluation circuit and printed-circuit layout, are shown in figures 12 and 13. This circuit provides a fixed 5.1 to 40V output (set by the divider R7/R8) and uses all the features of the L296. Indications for the choice of component values are summarized in figure 14.

Other application examples are illustrated on the following pages, (figures 15 to 21).

Fig. 12 - This is the evaluation circuit suggested for the L296. All the device's features are exercised. R4 is not strictly necessary.

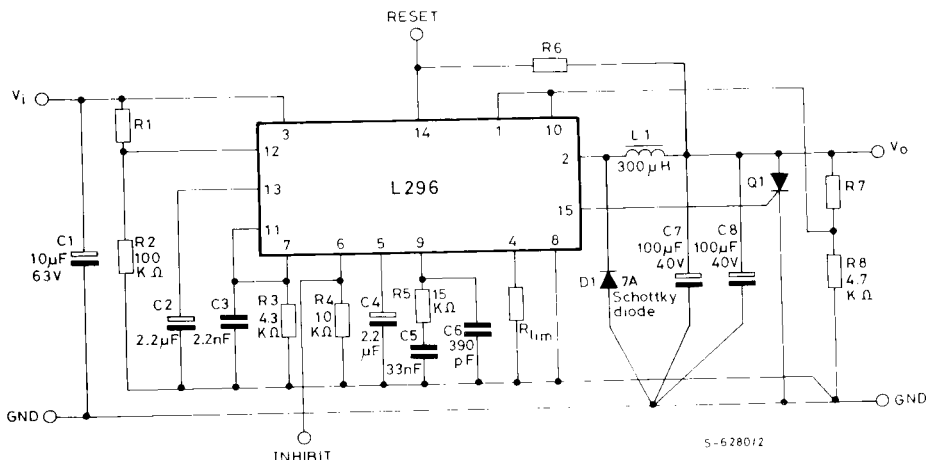

Fig. 13 - Suggested component layout for the figure 12 circuit. Care is needed when laying out circuits of this type or performance can be compromised. (1:1 scale)

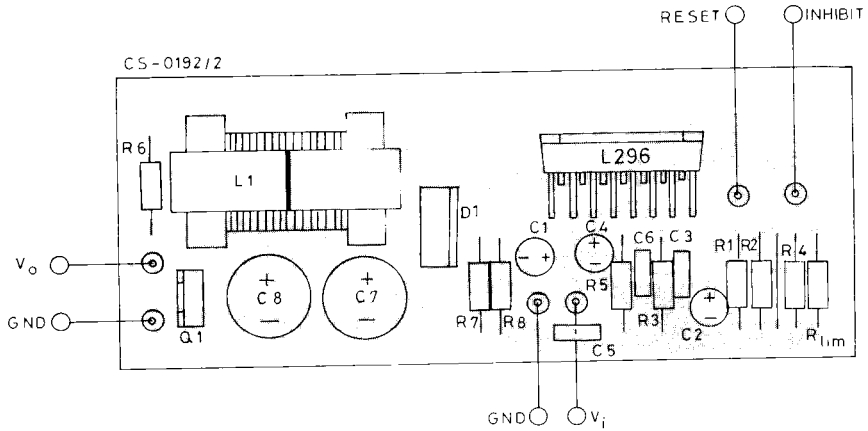
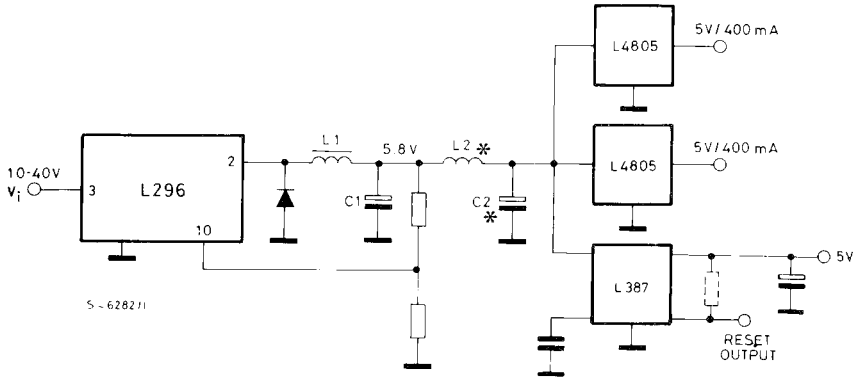

Fig. 14 - These tables indicate the suggested component values and limits for the figure 12 circuit.

Component	Recommended Value	Purpose	Allowed range		NOTES
			Min	Max	
R1 R2	- 100 kΩ	Set input voltage threshold for reset.	-	-	$R1/R2 = \frac{V_i \text{ min}}{5} - 1$ If output voltage is sensed R1 and R2 may be limited and pin 12 connected to pin 10.
R3	4.3 kΩ	Sets switching frequency	1 kΩ	100 kΩ	
R4	10 kΩ	Pull-down resistor		22 kΩ	May be omitted and pin 6 grounded if inhibit not used.
R5	15 kΩ	Frequency compensation	10 kΩ		
R6		Collector load for reset output	$\frac{V_o}{0.05A}$		Omitted if reset function not used.
R7 R8	- 4.7 kΩ	Divider to set output voltage	-	10 kΩ	$R7/R8 = \frac{V_o - V_{ref}}{V_{ref}}$
R _{lim}	-	Sets current limit level			If R _{lim} is omitted and pin 4 left open the current limit is internally fixed.
C1	10 μF	Stability	1 μF		
C2	2.2 μF	Sets reset delay	-	-	Omitted if reset function not used.
C3	2.2 nF	Sets switching frequency	1 nF	3.3 nF	
C4	2.2 μF	Soft start	1 μF		Also determines average short circuit current.
C5	33 nF	Frequency compensation			
C6	390 pF	High frequency compensation	-	-	Not required for 5V operation
C7,C8 L1	100 μF 300 μH	Output filter			
Q1		Crowbar protection			The SCR must be able to withstand the peak discharge current of the output capacitor and the short circuit current of the device.
D1		Recirculation diode			7A schottky or high efficiency diode in D0220 package

Fig. 17 - The L296's also useful as a preregulator in distributed supply systems. Using very low drop series regulators such as the SGS L4805 the overall efficiency is very high.



* $L2$ and $C2$ are necessary to reduce the switching frequency spikes.

Fig. 18 - Three L296's can be connected to form a 5.1V/15V/24V supply. Note that the three devices are synchronized to avoid intermodulation.

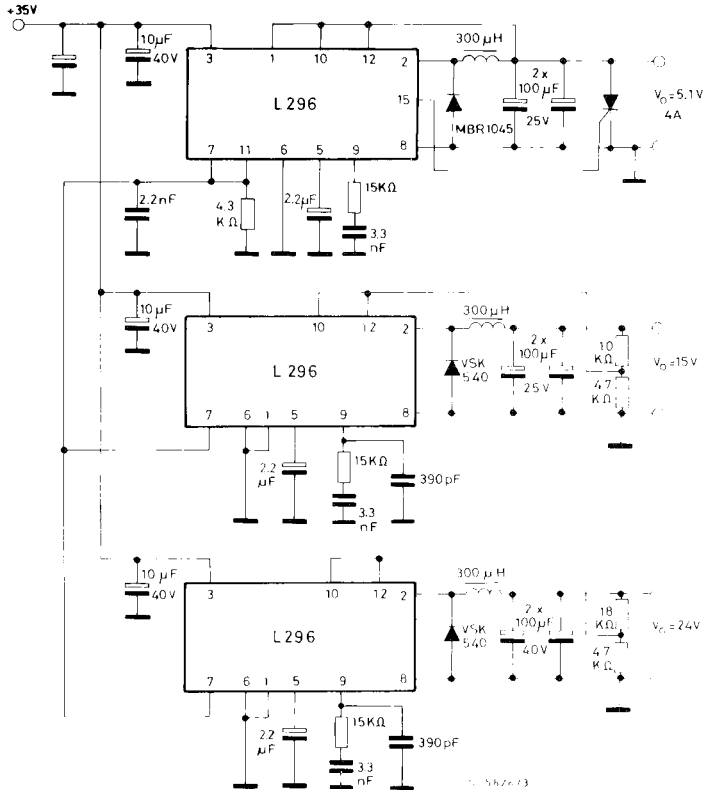
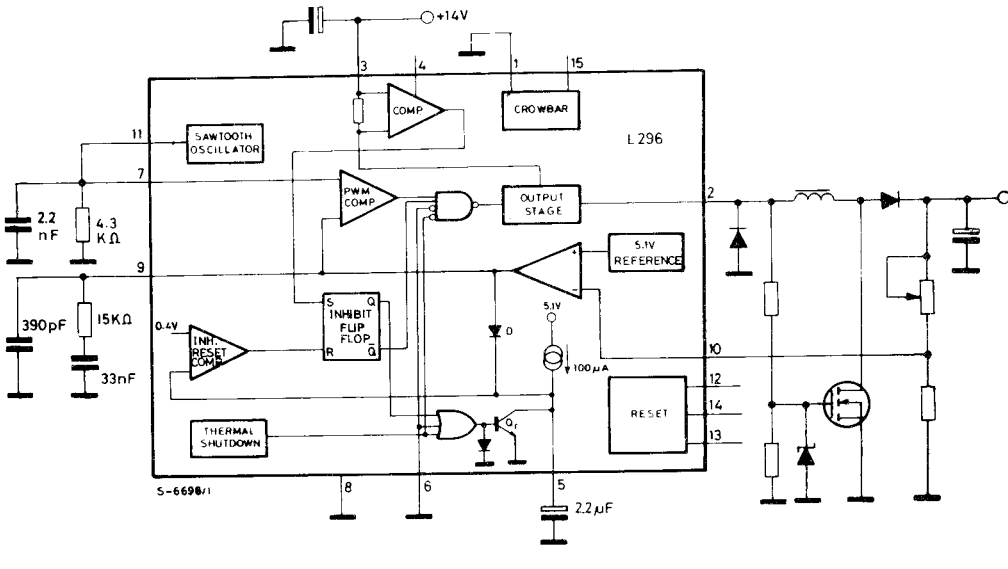

Fig. 21 - An external power MOS transistor is used to produce the step-up configuration shown schematically here.



SWITCHING vs LINEAR

Switching regulators are more efficient than linear types so the transformer and heatsink can be smaller and cheaper. But how much can you gain? We can estimate the savings by comparing equivalent linear and switching regulators. For example, suppose that we want a 4A/5V supply.

Linear

For a good linear regulator the minimum dropout will be at least 4V at 4A. The minimum input voltage is given by:

$$V_{i \min} = V_O + V_{\text{DROP}} + \frac{1}{2} V_{\text{ripple}}$$

$$\text{where } V_{\text{ripple}} \cong \frac{I_O t_1}{C} = \frac{4 \times 8 \times 10^{-3}}{10 \times 10^{-3}} = 3.2\text{V}$$

(a good approximation is 8 ms for t_1 (at mains frequency of 50 Hz) and 1000 μF for C, the filter capacitor after the bridge).

Therefore $V_{i \min} \cong 10.6\text{V}$.

Since operation must be guaranteed even when the mains voltage falls 20%, the nominal voltage on load at the terminals of the regulator must be:

$$V_{\text{nom}} = \frac{V_{i \min}}{0.8} = \frac{10.6}{0.8} = 13.25\text{V}$$

To allow even a small margin we have to choose:

$$V_{\text{nom}} = 14\text{V}$$

The power that the series element must dissipate

is therefore:

$$P_d = (V_{\text{nom}} - V_O) I_O = 36\text{W}$$

and the transformer must supply a power of:

$$P_{\text{diss}} = 14 \times 4 = 56\text{W}$$

It must therefore be dimensioned for:

$$P_D = \frac{56}{0.9} = 62\text{ VA}$$

and a heatsink will be necessary with a thermal resistance of:

$$R_{\text{th heats.}} = 0.8^\circ\text{C/W}$$

Fig. 22 - Ripple at output of linear regulator.

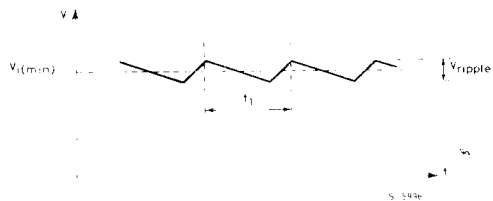

Switching (L296)

Assuming the same nominal voltage (14V), the L296 data sheet indicates that the power dissipated in this case is only 7W. And this power is dissipated

in two elements; the L296 itself and the recirculation diode.

It follows that the transformer must be roughly 30 VA and the heatsink thermal resistance about 11°C/W.

	Linear	Switching
Transformer	62 VA	30 VA
Heatsink	0.8° C/W	11° C/W

This comparison shows that the L296 switching regulator allows a saving of roughly 50% on the cost of active and passive components is roughly the same on the cost of the heatsink. Considering also the extra functions integrated by the L296 the total cost of active and passive components is roughly the same for both types.

If for some reason it is necessary to use higher supply voltages the switching technique, and hence the L296, becomes even more advantageous.

ION-IMPLANTED ISOLATION

The L296 exploits an advanced bipolar process which allows the combination of fast-switching

high power devices and dense control circuitry on the same chip. One of the key features of this process is the use of a two-step ion-implantation technique to form the isolation wells.

Normally this isolation is created by diffusing p-type impurities from above. The result is a bowl-like cross section which wastes silicon area (figure 23). Moreover, since prolonged high temperature processing is needed to perform this diffusion, the n⁺ buried layer spreads, reducing the breakdown voltage.

In the SGS process, a heavy p⁺ implant is made before, the n⁻ epitaxial collector growth, followed by a predeposition/drive-in from above. When the wafer is heated the two parts diffuse, joining in the middle to create a narrow isolation well (figure 24). Since high temperature processing is much reduced the n⁺ buried layer spreads very little and the resulting NPN transistor has a breakdown voltage in excess of 50V.

The narrower isolation results in an increased density, with minimal geometry transistors reduced to a compact 18 mil². Speed is correspondingly increased.

Teamed with the Multiwatt[®] plastic package, this process allows the integration of complex devices handling in excess of 200W. Other devices already introduced include the L295 dual solenoid driver (220W), the L294 switchmode driver (180W) and the L298 dual bridge driver (200W).

Fig. 23 - In standard bipolar technologies the isolation is diffused from above giving a bowl-shaped cross section which reduces the active silicon area. Also, prolonged high temperature processing causes out-diffusion of the buried layer.

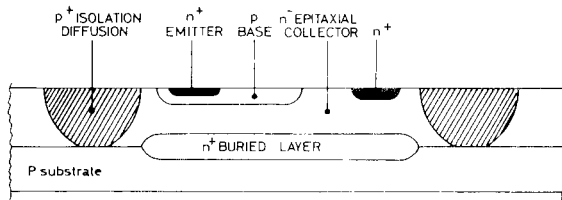

S-6001

Fig. 24 - SGS' above/below ion-implanted isolation is more compact and results in an increased n thickness between base and buried layer, raising the breakdown voltage.

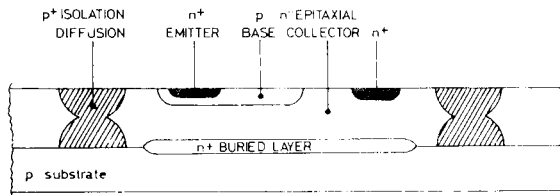

S-6000