

# MITSUBISHI LSIs

## M5M5165P, FP-70, -10, -12, -15, -70L, -10L, -12L, -15L

65536-BIT (8192-WORD BY 8-BIT) CMOS STATIC RAM

### DESCRIPTION

The M5M5165P, FP is a 65536-bit CMOS static RAM organized as 8192 words by 8 bits which is fabricated using high-performance double polysilicon CMOS technology. The use of resistive load NMOS cells and CMOS periphery result in a high-density and low-power static RAM. It is ideal for the memory systems which require simple interface.

The stand-by current is low enough for a battery back-up application.

### FEATURES

Type	Access time (max)	Power supply current	
		Active (max)	Stand-by (max)
M5M5165P, FP-70	70ns	50mA	2mA
M5M5165P, FP-10	100ns		
M5M5165P, FP-12	120ns		
M5M5165P, FP-15	150ns		
M5M5165P, FP-70L	70ns	20 $\mu$ A	20 $\mu$ A
M5M5165P, FP-10L	100ns	10 $\mu$ A	10 $\mu$ A
M5M5165P, FP-12L	120ns		
M5M5165P, FP-15L	150ns		

- Single +5V Power Supply
- Fully Static Operation: No Clocks, No Refresh
- Data-Hold on +2V Power Supply
- Directly TTL Compatible: All Inputs and Outputs
- Three-State Outputs: OR-tie Capability
- Simple Memory Expansion by  $\overline{S}_1, S_2$
- $\overline{OE}$  Prevents Data Contention in The I/O Bus
- Common Data I/O

### APPLICATION

Small Capacity Memory Units.

### FUNCTION

The operation mode of the M5M5165P, FP is determined by a combination of the device control inputs  $\overline{S}_1, S_2, \overline{W}$

### PIN CONFIGURATION (TOP VIEW)

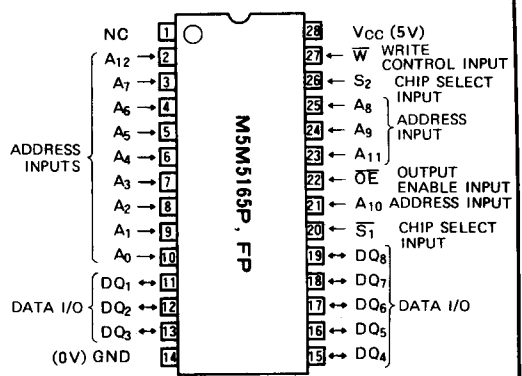

NC: NO CONNECTION  
 Outline 28P4 (DIP)  
 28P2W-C (SOP)

and  $\overline{OE}$ . Each mode is summarized in the function table. (see next page)

A write cycle is executed whenever the low level  $\overline{W}$  overlaps with the low level  $\overline{S}_1$  and the high level  $S_2$ . The address must be set up before the write cycle and must be stable during the entire cycle. The data is latched into a cell on the trailing edge of  $\overline{W}, \overline{S}_1$  or  $S_2$ , whichever occurs first, requiring the set-up and hold time relative to these edge to be maintained. The Output enable input  $\overline{OE}$  directly controls the output stage. Setting the  $\overline{OE}$  at a high level, the output stage is in a high-impedance state, and the data bus contention problem in the write cycle is eliminated.

A read cycle is executed by setting  $\overline{W}$  at a high level and  $\overline{OE}$  at a low level while  $\overline{S}_1$  and  $S_2$  are in an active state ( $\overline{S}_1=L, S_2=L$ ).

### BLOCK DIAGRAM

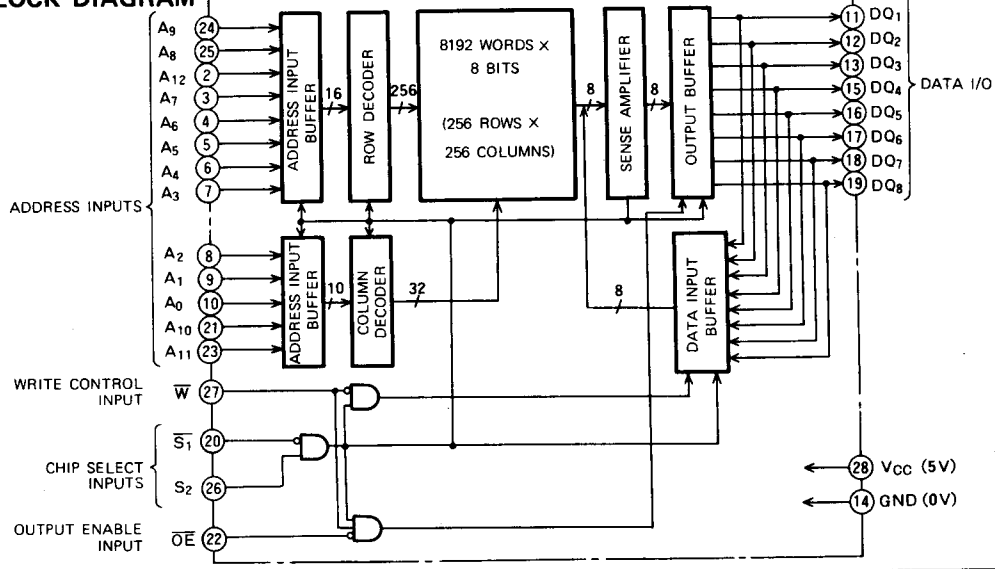

## M5M5165P, FP-70, -10, -12, -15, -70L, -10L, -12L, -15L

## 65536-BIT (8192-WORD BY 8-BIT) CMOS STATIC RAM

 $S_2 = H$ 

When setting  $\overline{S_1}$  at a high level or  $S_2$  at a low level, the chip is in a non-selectable mode in which both reading and writing are disabled. In this mode, the output stage is in a high-impedance state, allowing OR-tie with other chips and memory expansion by  $\overline{S_1}$  and  $S_2$ . The power supply current is reduced as low as the stand-by current which is specified as  $I_{CC3}$  or  $I_{CC4}$ , and the memory data can be held at +2V power supply, enabling battery back-up operation during power failure or power-down operation in the non-selected mode.

## FUNCTION TABLE

$\overline{S_1}$	$S_2$	$\overline{W}$	$\overline{OE}$	Mode	DQ	$I_{CC}$
X	L	X	X	Non selection	high-impedance	Standby
H	X	X	X	Non selection	high-impedance	Standby
L	H	L	X	Write	$D_{IN}$	Active
L	H	H	L	Read	$D_{OUT}$	Active
L	H	H	H		high-impedance	Active

## ABSOLUTE MAXIMUM RATINGS

Symbol	Parameter	Conditions	Ratings	Unit
$V_{CC}$	Supply voltage	With respect to GND	-0.3 ~ 7	V
$V_I$	Input voltage		-0.3 ~ $V_{CC} + 0.3$	V
$V_O$	Output voltage		0 ~ $V_{CC}$	V
$P_d$	Power dissipation	$T_a = 25^\circ\text{C}$	700	mW
$T_{opr}$	Operating temperature		0 ~ 70	$^\circ\text{C}$
$T_{stg}$	Storage temperature		-65 ~ 150	$^\circ\text{C}$

ELECTRICAL CHARACTERISTICS ( $T_a = 0 \sim 70^\circ\text{C}$ ,  $V_{CC} = 5V \pm 10\%$ , unless otherwise noted)

Symbol	Parameter	Test conditions	Limits			Unit
			Min	Typ	Max	
$V_{IH}$	High input voltage		2.2		$V_{CC} + 0.3$	V
$V_{IL}$	Low input voltage		-0.3		0.8	V
$V_{OH}$	High output voltage	$I_{OH} = -1\text{mA}$	2.4			V
$V_{OL}$	Low output voltage	$I_{OL} = 2\text{mA}$			0.4	V
$I_I$	Input current	$V_I = 0 \sim V_{CC}$			$\pm 1$	$\mu\text{A}$
$I_{OZH}$	High level output current in off-state	$\overline{S_1} = V_{IH}$ or $S_2 = V_{IL}$ or $\overline{OE} = V_{IH}$			1	$\mu\text{A}$
$I_{OZL}$	Low level output current in off-state	$V_I = 0 \sim V_{CC}$			-1	$\mu\text{A}$
$I_{CC1}$	Active supply current	$\overline{S_1} \leq 0.2$ , $S_2 \geq V_{CC} - 0.2$ Output open Other inputs $\leq 0.2$ or $\geq V_{CC} - 0.2$		30	45	mA
$I_{CC2}$	Active supply current	$\overline{S_1} = V_{IL}$ or $S_2 = V_{IH}$ Output open Other inputs = $V_{IH}$		35	50	mA
$I_{CC3}$	Stand-by supply current	① $S_2 \leq 0.2V$ , Other inputs = $0 \sim V_{CC}$ ② $\overline{S_1} \geq V_{CC} - 0.2V$ , $S_2 \geq V_{CC} - 0.2V$ , Other inputs = $0 \sim V_{CC}$	P, FP		2	mA
			P, FP-L		20	$\mu\text{A}$
$I_{CC4}$	Stand-by supply current	$S_2 = V_{IL}$ , $\overline{S_1} = V_{IH}$ , Other inputs = $0 \sim V_{CC}$			3	mA
$C_i$	Input capacitance ( $T_a = 25^\circ\text{C}$ )	$V_I = \text{GND}$ , $V_i = 25\text{mVrms}$ , $f = 1\text{MHz}$			6	pF
$C_o$	Output capacitance ( $T_a = 25^\circ\text{C}$ )	$V_O = \text{GND}$ , $V_o = 25\text{mVrms}$ , $f = 1\text{MHz}$			8	pF

Note 1 Direction for current flowing into IC is indicated as positive (no mark)

2. Typical value is  $V_{CC} = 5V$ ,  $T_a = 25^\circ\text{C}$

# M5M5165P, FP-70, -10, -12, -15, -70L, -10L, -12L, -15L

## 65536-BIT (8192-WORD BY 8-BIT) CMOS STATIC RAM

### SWITCHING CHARACTERISTICS (T<sub>a</sub> = 0 ~ 70°C, V<sub>CC</sub> = 5V ± 10%, unless otherwise noted)

#### Read cycle

Symbol	Parameter	Limits												Unit
		M5M5165P, FP-70 M5M5165P, FP-70L			M5M5165P, FP-10 M5M5165P, FP-10L			M5M5165P, FP-12 M5M5165P, FP-12L			M5M5165P, FP-15 M5M5165P, FP-15L			
		Min	Typ	Max	Min	Typ	Max	Min	Typ	Max	Min	Typ	Max	
t <sub>CR</sub>	Read cycle time	70			100			120			150			ns
t <sub>a</sub> (A)	Address access time			70			100			120			150	ns
t <sub>a</sub> (S <sub>1</sub> )	Chip select 1 access time			70			100			120			150	ns
t <sub>a</sub> (S <sub>2</sub> )	Chip select 2 access time			70			100			120			150	ns
t <sub>a</sub> (OE)	Output enable access time			35			50			60			70	ns
t <sub>dis</sub> (S <sub>1</sub> )	Output disable time after S <sub>1</sub> high			30			35			40			50	ns
t <sub>dis</sub> (S <sub>2</sub> )	Output disable time after S <sub>2</sub> low			30			35			40			50	ns
t <sub>dis</sub> (OE)	Output disable time after OE high			30			35			40			50	ns
t <sub>en</sub> (S <sub>1</sub> )	Output enable time after S <sub>1</sub> low	5			10			10			10			ns
t <sub>en</sub> (S <sub>2</sub> )	Output enable time after S <sub>2</sub> high	5			10			10			10			ns
t <sub>en</sub> (OE)	Output enable time after OE low	5			10			10			10			ns
t <sub>v</sub> (A)	Data valid time after address change	20			20			20			20			ns

### TIMING REQUIREMENTS (T<sub>a</sub> = 0 ~ 70°C, V<sub>CC</sub> = 5V ± 10%, unless otherwise noted)

#### Write cycle

Symbol	Parameter	Limits												Unit
		M5M5165P, FP-70 M5M5165P, FP-70L			M5M5165P, FP-10 M5M5165P, FP-10L			M5M5165P, FP-12 M5M5165P, FP-12L			M5M5165P, FP-15 M5M5165P, FP-15L			
		Min	Typ	Max	Min	Typ	Max	Min	Typ	Max	Min	Typ	Max	
t <sub>OW</sub>	Write cycle time	70			100			120			150			ns
t <sub>w</sub> (W)	Write pulse width	40			60			70			90			ns
t <sub>SU</sub> (A)	Address set up time	0			0			0			0			ns
t <sub>SU</sub> (S)	Chip select set up time	65			80			85			100			ns
t <sub>SU</sub> (D)	Data set up time	30			35			40			50			ns
t <sub>h</sub> (D)	Data hold time	5			5			5			5			ns
t <sub>rec</sub> (W)	Write recovery time	5			5			10			10			ns
t <sub>dis</sub> (W)	Output disable time after W low	0		30			35			40			50	ns
t <sub>dis</sub> (OE)	Output disable time after OE high	0		30			35			40			50	ns
t <sub>en</sub> (W)	Output enable time after W high	5			10			10			10			ns
t <sub>en</sub> (OE)	Output enable time after OE low	5			10			10			10			ns

**65536-BIT (8192-WORD BY 8-BIT) CMOS STATIC RAM**

**TIMING DIAGRAM**

**Read cycle**

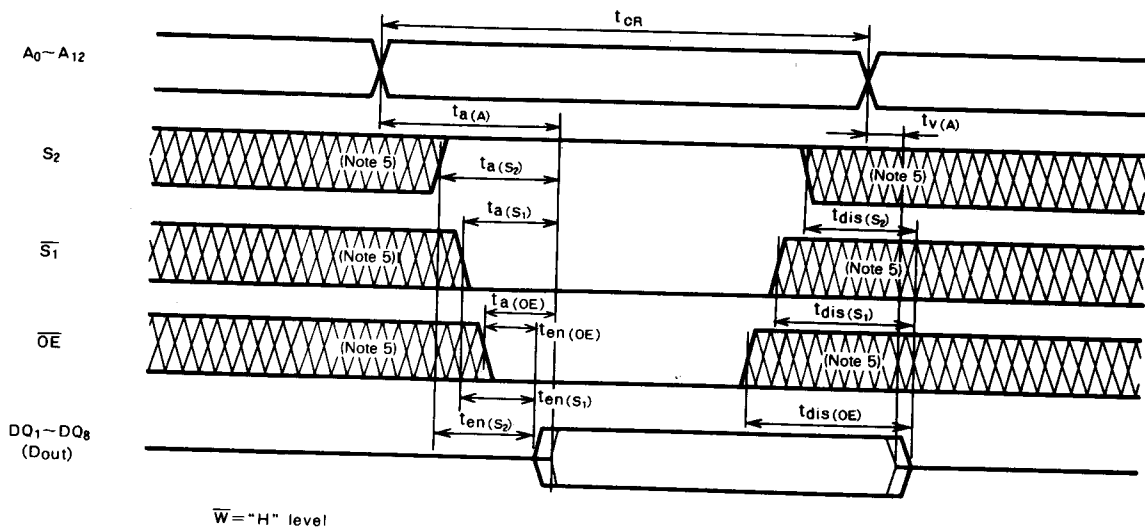

**Write cycle ( $\overline{W}$  control)**

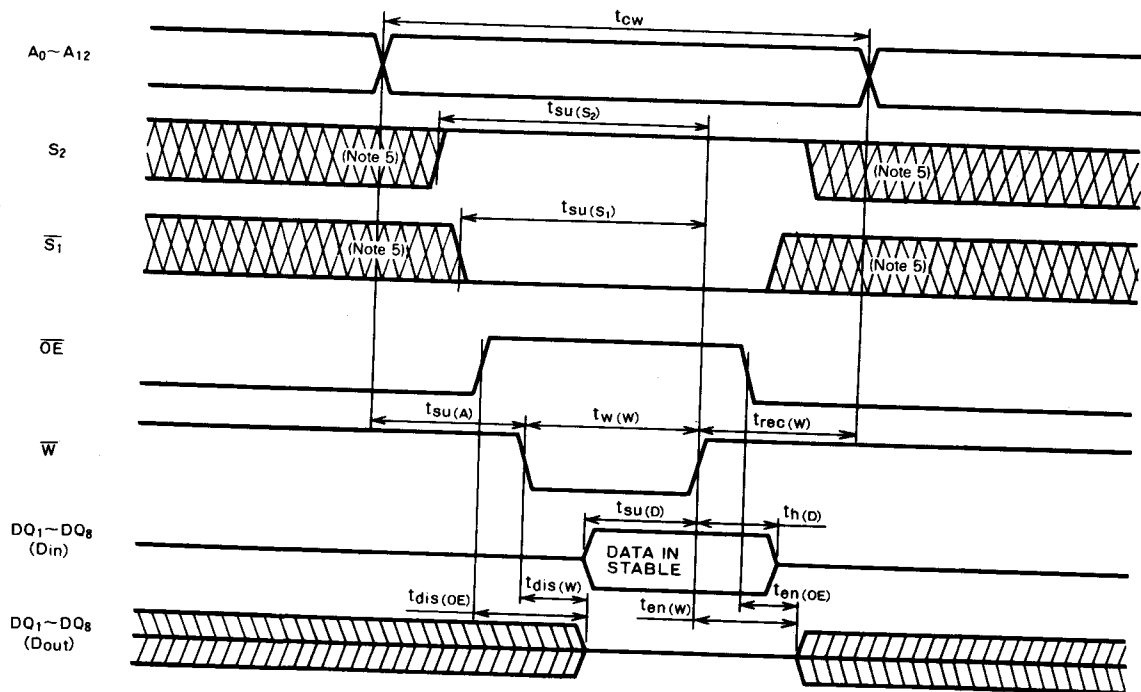

# M5M5165P, FP-70, -10, -12, -15, -70L, -10L, -12L, -15L

## 65536-BIT (8192-WORD BY 8-BIT) CMOS STATIC RAM

### Write cycle (S control)

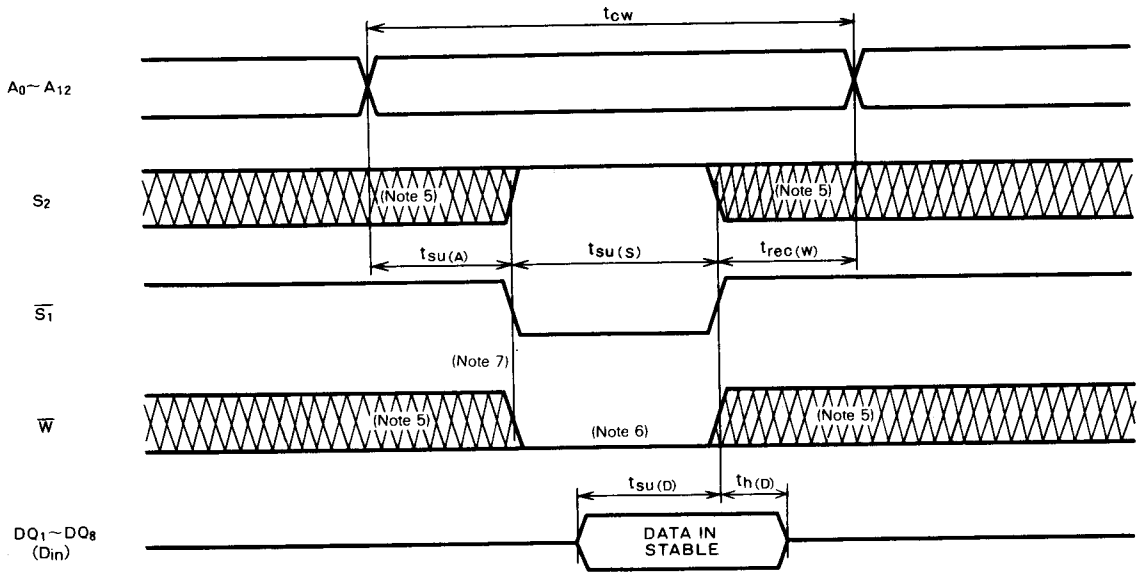

**Note 4: Test condition**

Input pulse level . . . .  $V_{IH} = 2.4V, V_{IL} = 0.6V$

Input rise and fall time . . . . 10ns

Reference level . . . .  $V_{OH} = V_{OL} = 1.5V$

Transition is measured  $\pm 500mV$  from steady state voltage. (for  $t_{on}, t_{dis}$ )

Output loads . . . . . Fig. 1,  $C_L = 100pF$  (P, FP-10, -12, -15, -10L, -12L, -15L)

$C_L = 30pF$  (P, FP-70, -70L)

$C_L = 5pF$  (for  $t_{on}, t_{dis}$ )

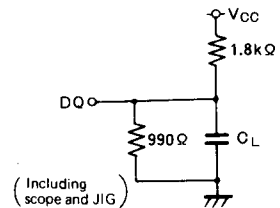

**Fig. 1 Output load**

Note 5: Hatching indicates the state is don't care.

6: Writing is executed while  $S_2$  high overlaps  $S_1$  and  $\bar{W}$  low.

7: If  $\bar{W}$  goes low simultaneously with or prior to  $S_1$  low or  $S_2$  high, the output remains in the high-impedance state.

8: Don't apply inverted phase signal externally when DQ pin is in output mode.

# M5M5165P, FP-70, -10, -12, -15, -70L, -10L, -12L, -15L

## 65536-BIT (8192-WORD BY 8-BIT) CMOS STATIC RAM

### POWER DOWN CHARACTERISTICS

#### ELECTRICAL CHARACTERISTICS (Ta = 0 ~ 70°C, unless otherwise noted)

Symbol	Parameter	Test conditions	Limits			Unit
			Min	Typ	Max	
V <sub>CC(PD)</sub>	Power down supply voltage		2			V
V <sub>I</sub> ( $\overline{S}_1$ )	Chip select input $\overline{S}_1$	2.2V ≤ V <sub>CC(PD)</sub>	2.2			V
		2V ≤ V <sub>CC(PD)</sub> ≤ 2.2V		V <sub>CC(PD)</sub>		
V <sub>I</sub> (S <sub>2</sub> )	Chip select input S <sub>2</sub>	4.5V ≤ V <sub>CC(PD)</sub>			0.8	V
		V <sub>CC(PD)</sub> < 4.5V			0.2	
I <sub>CC(PD)</sub>	Power down supply current	V <sub>CC</sub> = 3V, Other inputs = 3V	P, FP		2	mA
			P, FP-L		10 *	μA

Note 3: When  $\overline{S}_1$  is operated at 2.2V (V<sub>IH</sub> min) and the supply voltage is between 4.5V and 2.4V, supply current is defined as I<sub>CC</sub>.

\*: I<sub>CC(PD)</sub> = 1 μA at Ta = 25°C

### TIMING REQUIREMENTS (Ta = 0 ~ 70°C, unless otherwise noted)

Symbol	Parameter	Test conditions	Limits			Unit
			Min	Typ	Max	
t <sub>SU(PD)</sub>	Power down setup time		0			ns
t <sub>REC(PD)</sub>	Power down recovery time		t <sub>CR</sub>			ns

### POWER DOWN CHARACTERISTICS

#### $\overline{S}_1$ control

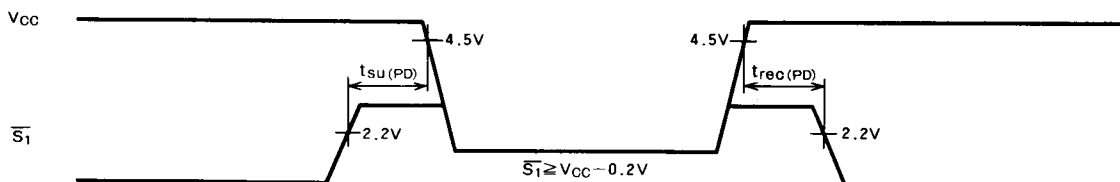

#### S<sub>2</sub> control

