

**MC68HC11A8
MC68HC11A1
MC68HC11A0****Technical Summary**
8-Bit Microcontrollers**Introduction**

The MC68HC11A8, MC68HC11A1, and MC68HC11A0 high-performance microcontroller units (MCUs) are based on the M68HC11 Family. These high speed, low power consumption chips have multiplexed buses and a fully static design. The chips can operate at frequencies from 3 MHz to dc. The three MCUs are created from the same masks; the only differences are the value stored in the CONFIG register, and whether or not the ROM or EEPROM is tested and guaranteed.

For detailed information about specific characteristics of these MCUs, refer to the *M68HC11 Reference Manual*, document number M68HC11 RM/AD.

Features

- M68HC11 CPU
- Power Saving STOP and WAIT Modes
- 8 KBytes ROM
- 512 Bytes of On-Chip EEPROM
- 256 Bytes of On-Chip RAM (All Saved During Standby)
- 16-Bit Timer System
 - 3 Input Capture Channels
 - 5 Output Compare Channels
- 8-Bit Pulse Accumulator
- Real-Time Interrupt Circuit
- Computer Operating Properly (COP) Watchdog System
- Synchronous Serial Peripheral Interface (SPI)
- Asynchronous Nonreturn to Zero (NRZ) Serial Communications Interface (SCI)
- 8-Channel, 8-Bit Analog-to-Digital (A/D) Converter
- 38 General-Purpose Input/Output (I/O) Pins
 - 15 Bidirectional I/O Pins
 - 11 Input-Only Pins and 12 Output-Only Pins (Eight Output-Only Pins in 48-Pin Package)
- Available in 48-Pin Dual In-Line Package (DIP) or 52-Pin Plastic Leaded Chip Carrier (PLCC)



MC68HC11Ax Family Members

Device Number	ROM	EEPROM	RAM	CONFIG*	Comments
MC68HC11A8	8K	512	256	\$0F	Family built around this device
MC68HC11A1	0	512	256	\$0D	ROM disabled
MC68HC11A0	0	0	256	\$0C	ROM and EEPROM disabled

*Value programmed at Motorola

Ordering Information

Package	Temperature	CONFIG	Description	MC Order Number
48-Pin Plastic DIP (P suffix)	- 40° to + 85°C	\$0F	BUFFALO ROM	MC68HC11A8P1
	- 40° to + 85°C	\$0D	No ROM	MC68HC11A1P
	- 40° to + 105°C	\$0D	No ROM	MC68HC11A1VP
	- 40° to + 125°C	\$0D	No ROM	MC68HC11A1MP
	- 40° to + 85°C	\$09	No ROM, COP On	MC68HCP11A1P
	- 40° to + 105°C	\$09	No ROM, COP On	MC68HCP11A1VP
	- 40° to + 125°C	\$09	No ROM, COP On	MC68HCP11A1MP
	- 40° to + 85°C	\$0C	No ROM, No EEPROM	MC68HC11A0P

52-Pin PLCC (FN suffix)	- 40° to + 85°C	\$0F	BUFFALO ROM	MC68HC11A8FN1
	- 40° to + 85°C	\$0D	No ROM	MC68HC11A1FN
	- 40° to + 105°C	\$0D	No ROM	MC68HC11A1VFN
	- 40° to + 125°C	\$0D	No ROM	MC68HC11A1MFN
	- 40° to + 85°C	\$09	No ROM, COP On	MC68HCP11A1FN
	- 40° to + 105°C	\$09	No ROM, COP On	MC68HCP11A1VFN
	- 40° to + 125°C	\$09	No ROM, COP On	MC68HCP11A1MFN
	- 40° to + 85°C	\$0C	No ROM, No EEPROM	MC68HC11A0FN

Table of Contents

Introduction.....1
Features1
MC68HC11Ax Family Members2
Ordering Information.....2
Register Index.....4
MC68HC11A8 Block Diagram.....5
52-Pin PLCC Pin Assignments.....6
48-Pin DIP Pin Assignments.....7
Operating Modes and Memory Maps.....8
Memory Maps.....9
MC68HC11A8 Register and Control Bit Assignments10
Resets and Interrupts.....14
Electrically Erasable Programmable Read-Only Memory (EEPROM)19
Parallel Input/Output.....21
Serial Communications Interface (SCI).....26
Serial Peripheral Interface (SPI).....33
Main Timer.....37
Pulse Accumulator.....45
Analog-to-Digital Converter48

Freescale Semiconductor, Inc.

Register Index

Register		Address	Page
PORTA	Port A Data	\$1000	22
PIOC	Parallel I/O Control	\$1002	22
PORTC	Port C Data	\$1003	23
PORTB	Port B Data	\$1004	24
PORTCL	Port C Latched	\$1005	24
DDRC	Data Direction Register for Port C	\$1007	24
PORTD	Port D Data	\$1008	24
DDRD	Data Direction Register for Port D	\$1009	25, 34
PORTE	Port E Data	\$100A	25
CFORC	Timer Compare Force	\$100B	39
OC1M	Output Compare 1 Mask	\$100C	39
OC1D	Output Compare 1 Data	\$100D	39
TCNT	Timer Counter	\$100E, \$100F	39
TIC1–TIC3	Timer Input Capture	\$1010–\$1015	40
TOC1–TOC5	Timer Output Compare	\$1016–\$101F	40
TCTL1	Timer Control 1	\$1020	41
TCTL2	Timer Control 2	\$1021	41
TMSK1	Timer Interrupt Mask 1	\$1022	42
TFLG1	Timer Interrupt Flag 1	\$1023	42
TMSK2	Timer Interrupt Mask 2	\$1024	42, 46
TFLG2	Timer Interrupt Flag 2	\$1025	43, 46
PACTL	Pulse Accumulator Control	\$1026	25, 44, 47
PACNT	Pulse Accumulator Counter	\$1027	47
SPCR	Serial Peripheral Control Register	\$1028	34
SPSR	Serial Peripheral Status Register	\$1029	35
SPDR	SPI Data Register	\$102A	36
BAUD	Baud Rate	\$102B	28
SCCR1	SCI Control Register 1	\$102C	30
SCCR2	SCI Control Register 2	\$102D	30
SCSR	SCI Status Register	\$102E	31
SCDR	SCI Data Register	\$102F	32
ADCTL	A/D Control/Status	\$1030	50
ADR1–ADR4	A/D Results	\$1031–\$1034	51
OPTION	System Configuration Options	\$1039	16, 51
COPRST	Arm/Reset COP Timer Circuitry	\$103A	16
PPROG	EEPROM Programming Control	\$103B	19
HPRIO	Highest Priority I-Bit Interrupt and Miscellaneous	\$103C	12, 17
INIT	RAM and I/O Mapping	\$103D	12
TEST1	Factory Test	\$103E	13
CONFIG	COP, ROM, EEPROM Enables	\$103F	13, 18, 20

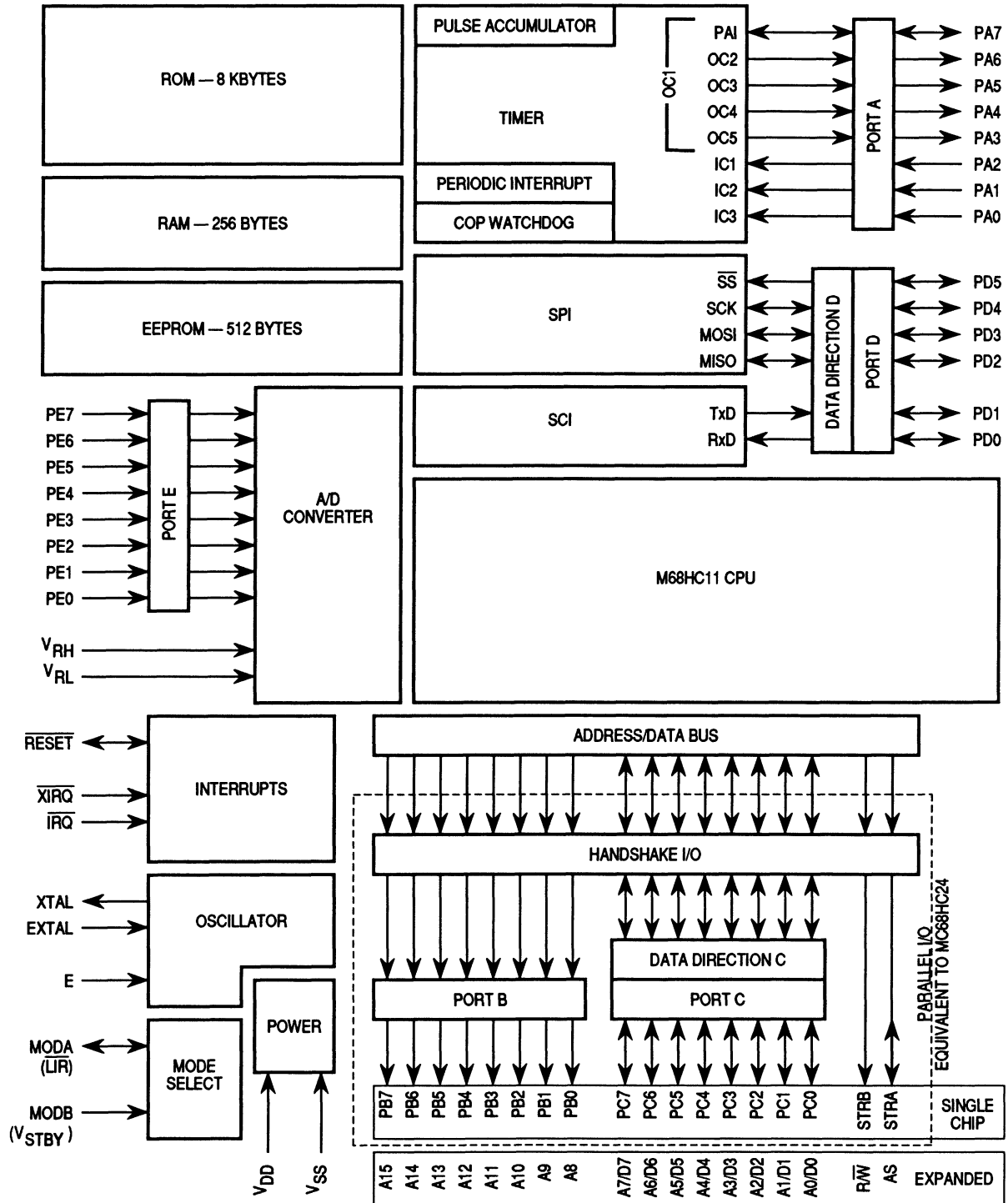

MC68HC11A8 Block Diagram

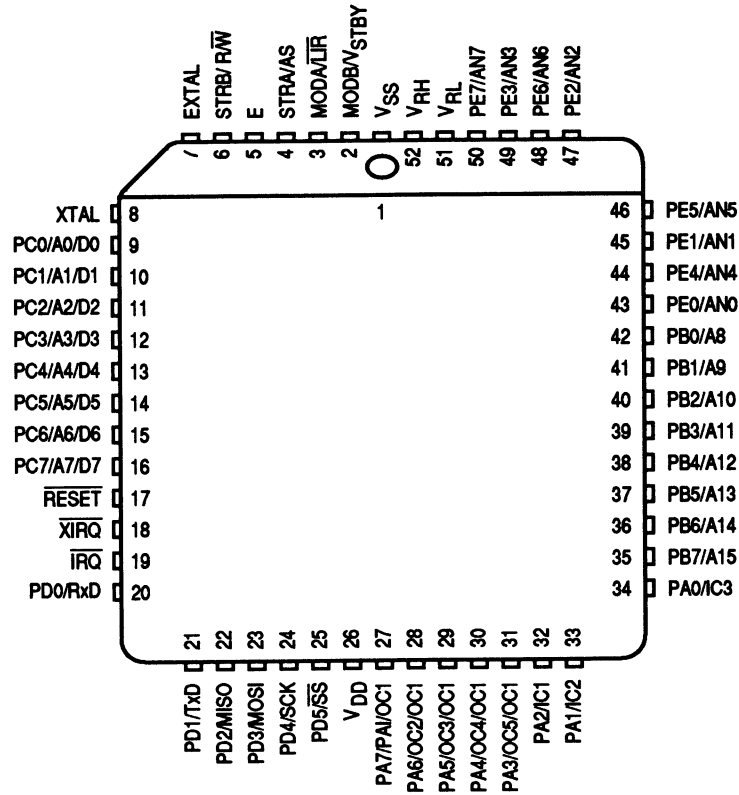

52-Pin PLCC Pin Assignments



48-Pin DIP Pin Assignments

In single-chip operating mode, the MC68HC11A8 is a monolithic microcontroller without external address or data buses.

In expanded multiplexed operating mode, the MCU can access a 64 Kbyte address space. The space includes the same on-chip memory addresses used for single-chip mode plus external peripheral and memory devices. The expansion bus is made up of ports B and C and control signals AS and $\overline{R/W}$. The address, $\overline{R/W}$, and AS signals are active and valid for all bus cycles including accesses to internal memory locations. The following figure illustrates a recommended method of demultiplexing low-order addresses from data at port C.

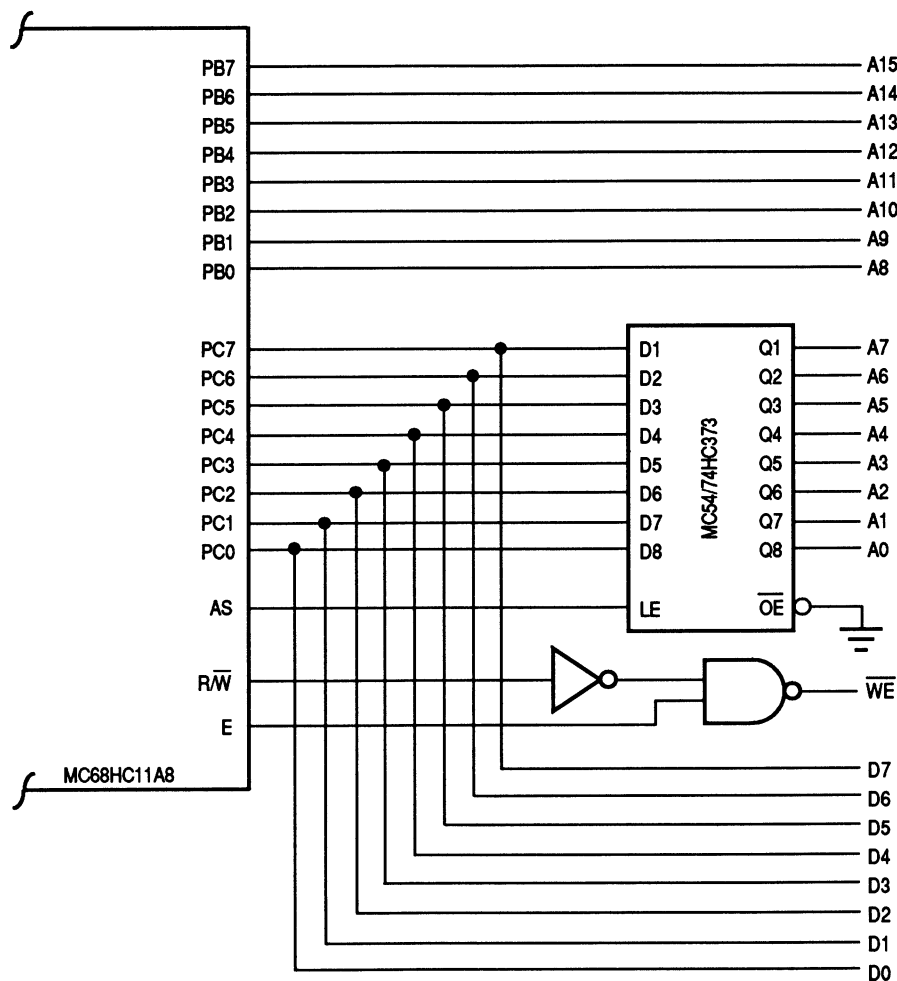

Address/Data Demultiplexing

Special bootstrap mode allows special purpose programs to be entered into internal RAM. The bootloader program uses the SCI to read a 256-byte program into on-chip RAM at \$0000 through \$00FF. After receiving the character for address \$00FF, control passes to the loaded program at \$0000.

Special test mode is used primarily for factory testing.

Memory locations are the same for expanded multiplexed and single-chip modes. The on-board 256-byte RAM is initially located at \$0000 after reset. The 64-byte register block originates at \$1000 after reset. RAM and/or the register block can be placed at any other 4K boundary (\$x000) after reset by writing an appropriate value to the INIT register. The 512-byte EEPROM is located at \$B600 through \$B7FF after reset if it is enabled. The 8 Kbyte ROM is located at \$E000 through \$FFFF if it is enabled.

Hardware priority is built into the memory remapping. Registers have priority over RAM, and RAM has priority over ROM. The higher priority resource covers the lower, making the underlying locations inaccessible.

In special bootstrap mode, a bootloader ROM is enabled at locations \$BF40 through \$BFFF.

In special test and special bootstrap modes, reset and interrupt vectors are located at \$BFC0 through \$BFFF.

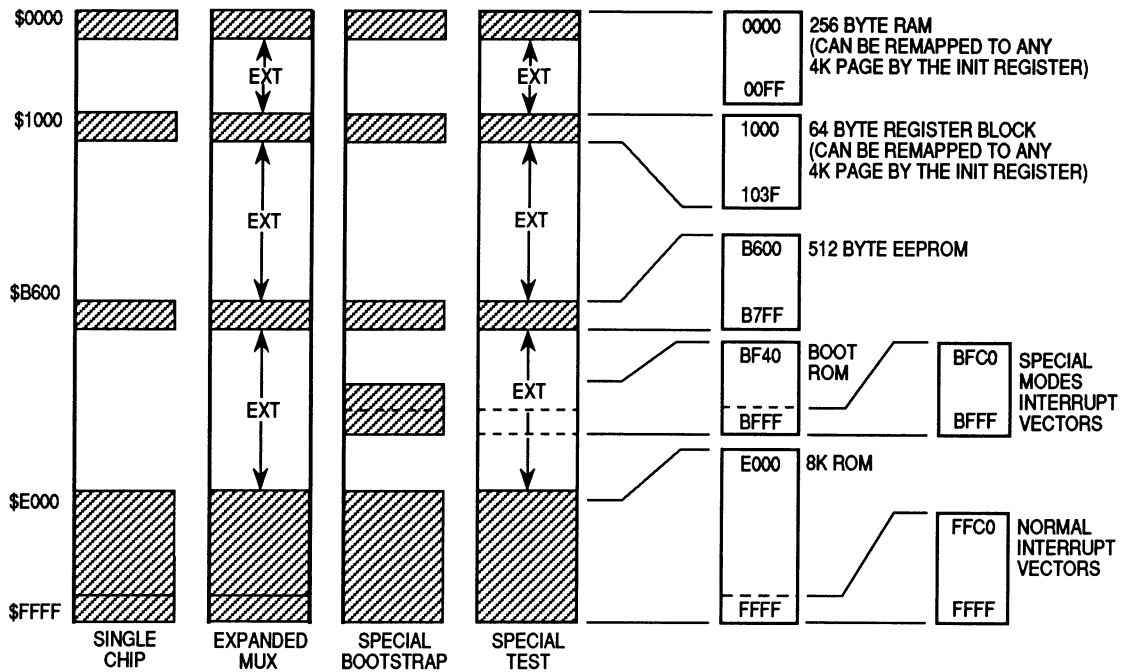

Memory Map

Freescale Semiconductor, Inc.

MC68HC11A8 Register and Control Bit Assignments (1 of 2)

(The register block can be remapped to any 4K boundary.)

	Bit 7	6	5	4	3	2	1	Bit 0	
\$1000	PA7	PA6	PA5	PA4	PA3	PA2	PA1	PA0	PORTA
\$1001									Reserved
\$1002	STAF	STAI	CWOM	HNDS	OIN	PLS	EGA	INVB	PIOC
\$1003	PC7	PC6	PC5	PC4	PC3	PC2	PC1	PC0	PORTC
\$1004	PB7	PB6	PB5	PB4	PB3	PB2	PB1	PB0	PORTB
\$1005	PCL7	PCL6	PCL5	PCL4	PCL3	PCL2	PCL1	PCL0	PORTCL
\$1006									Reserved
\$1007	DDC7	DDC6	DDC5	DDC4	DDC3	DDC2	DDC1	DDC0	DDRC
\$1008	0	0	PD5	PD4	PD3	PD2	PD1	PD0	PORTD
\$1009	0	0	DDD5	DDD4	DDD3	DDD2	DDD1	DDD0	DDRD
\$100A	PE7	PE6	PE5	PE4	PE3	PE2	PE1	PE0	PORTE
\$100B	FOC1	FOC2	FOC3	FOC4	FOC5	0	0	0	CFORC
\$100C	OC1M7	OC1M6	OC1M5	OC1M4	OC1M3	0	0	0	OC1M
\$100D	OC1D7	OC1D6	OC1D5	OC1D4	OC1D3	0	0	0	OC1D
\$100E	Bit 15	14	13	12	11	10	9	Bit 8	TCNT (High)
\$100F	Bit 7	6	5	4	3	2	1	Bit 0	TCNT (Low)
\$1010	Bit 15	14	13	12	11	10	9	Bit 8	TIC1 (High)
\$1011	Bit 7	6	5	4	3	2	1	Bit 0	TIC1 (Low)
\$1012	Bit 15	14	13	12	11	10	9	Bit 8	TIC2 (High)
\$1013	Bit 7	6	5	4	3	2	1	Bit 0	TIC2 (Low)
\$1014	Bit 15	14	13	12	11	10	9	Bit 8	TIC3 (High)
\$1015	Bit 7	6	5	4	3	2	1	Bit 0	TIC3 (Low)
\$1016	Bit 15	14	13	12	11	10	9	Bit 8	TOC1 (High)
\$1017	Bit 7	6	5	4	3	2	1	Bit 0	TOC1 (Low)
\$1018	Bit 15	14	13	12	11	10	9	Bit 8	TOC2 (High)
\$1019	Bit 7	6	5	4	3	2	1	Bit 0	TOC2 (Low)
\$101A	Bit 15	14	13	12	11	10	9	Bit 8	TOC3 (High)
\$101B	Bit 7	6	5	4	3	2	1	Bit 0	TOC3 (Low)
\$101C	Bit 15	14	13	12	11	10	9	Bit 8	TOC4 (High)
\$101D	Bit 7	6	5	4	3	2	1	Bit 0	TOC4 (Low)
\$101E	Bit 15	14	13	12	11	10	9	Bit 8	TOC5 (High)
\$101F	Bit 7	6	5	4	3	2	1	Bit 0	TOC5 (Low)

MC68HC11A8 Register and Control Bit Assignments (2 of 2)

	Bit 7	6	5	4	3	2	1	Bit 0	
\$1020	OM2	OL2	OM3	OL3	OM4	OL4	OM5	OL5	TCTL1
\$1021	0	0	EDG1B	EDG1A	EDG2B	EDG2A	EDG3B	EDG3A	TCTL2
\$1022	OC1I	OC2I	OC3I	OC4I	OC5I	IC1I	IC2I	IC3I	TMSK1
\$1023	OC1F	OC2F	OC3F	OC4F	OC5F	IC1F	IC2F	IC3F	TFLG1
\$1024	TOI	RTII	PAOVI	PAII	0	0	PR1	PR0	TMSK2
\$1025	TOF	RTIF	PAOVF	PAIF	0	0	0	0	TFLG2
\$1026	DDRA7	PAEN	PAMOD	PEDGE	0	0	RTR1	RTR0	PACTL
\$1027	Bit 7	6	5	4	3	2	1	Bit 0	PACNT
\$1028	SPIE	SPE	DWOM	MSTR	CPOL	CPHA	SPR1	SPR0	SPCR
\$1029	SPIF	WCOL	0	MODF	0	0	0	0	SPSR
\$102A	Bit 7	6	5	4	3	2	1	Bit 0	SPDR
\$102B	TCLR	0	SCP1	SCP0	RCKB	SCR2	SCR1	SCR0	BAUD
\$102C	R8	T8	0	M	WAKE	0	0	0	SCCR1
\$102D	TIE	TCIE	RIE	ILIE	TE	RE	RWU	SBK	SCCR2
\$102E	TDRE	TC	RDRF	IDLE	OR	NF	FE	0	SCSR
\$102F	R7/T7	R6/T6	R5/T5	R4/T4	R3/T3	R2/T2	R1/T1	R0/T0	SCDR
\$1030	CCF	0	SCAN	MULT	CD	OC	CB	CA	ADCTL
\$1031	Bit 7	6	5	4	3	2	1	Bit 0	ADR1
\$1032	Bit 7	6	5	4	3	2	1	Bit 0	ADR2
\$1033	Bit 7	6	5	4	3	2	1	Bit 0	ADR3
\$1034	Bit 7	6	5	4	3	2	1	Bit 0	ADR4
\$1035									Reserved
\$1038									Reserved
\$1039	ADPU	CSEL	IRQE	DLY	CME	0	CR1	CR0	OPTION
\$103A	Bit 7	6	5	4	3	2	1	Bit 0	COPRST
\$103B	ODD	EVEN	0	BYTE	ROW	ERASE	EELAT	EEPGM	PPROG
\$103C	RBOOT	SMOD	MDA	IRV	PSEL3	PSEL2	PSEL1	PSEL0	HPRIO
\$103D	RAM3	RAM2	RAM1	RAM0	REG3	REG2	REG1	REG0	INIT
\$103E	TILOP	0	OCCR	CBYP	DISR	FCM	FCOP	TCON	TEST1
\$103F	0	0	0	0	NOSEC	NOCOP	ROMON	EEON	CONFIG

HPRIO — Highest Priority I-Bit Interrupt and Miscellaneous

\$103C

	Bit 7	6	5	4	3	2	1	Bit 0
	RBOOT	SMOD	MDA	IRV	PSEL3	PSEL2	PSEL1	PSEL0
RESET:	—	—	—	—	0	1	0	1

RBOOT, SMOD, and MDA reset depend on conditions at reset and can only be written in special modes (SMOD = 1).

RBOOT — Read Bootstrap ROM

- 0 = Bootloader ROM disabled and not in map
- 1 = Bootloader ROM enabled and in map at \$BF40–\$BFFF

SMOD — Special Mode Select

MDA — Mode Select A

Inputs		Mode	Latched at Reset		
MODB	MODA		RBOOT	SMOD	MDA
1	0	Single Chip	0	0	0
1	1	Expanded Multiplexed	0	0	1
0	0	Special Bootstrap	1	1	0
0	1	Special Test	0	1	1

IRV — Internal Read Visibility

- 0 = No internal read visibility on external bus
- 1 = Data from internal reads is driven out through the external data bus

PSEL3–PSEL0 — Priority Select Bits 3 through 0

Refer to **Resets and Interrupts**.

INIT — RAM and I/O Mapping

\$103D

	Bit 7	6	5	4	3	2	1	Bit 0
	RAM3	RAM2	RAM1	RAM0	REG3	REG2	REG1	REG0
RESET:	0	0	0	0	0	0	0	1

RAM3–RAM0 — 256-Byte Internal RAM Map Position

RAM3–RAM0 determine the upper four bits of the RAM address, positioning RAM at the selected 4K boundary.

REG3–REG0 — 64-Byte Register Block Map Position

REG3–REG0 determine the upper four bits of the register address, positioning registers at the selected 4K boundary. Register can be written only once in the first 64 cycles out of reset in normal modes, or any time in special modes. Refer to **Operating Modes and Memory Maps** for additional information.

TEST1 — Factory Test

\$103E

	Bit 7	6	5	4	3	2	1	Bit 0
	TILOP	0	OCCR	CBYP	DISR	FCM	FCOP	TCON
RESET:	0	0	0	0	—	0	0	0

Test Modes Only

TILOP — Test Illegal Opcode

OCCR — Output Condition Code Register to Timer Port

CBYP — Timer Divider Chain Bypass

DISR — Disable Resets from COP and Clock Monitor

DISR is forced to one out of reset in special test and bootstrap modes.

FCM — Force Clock Monitor Failure

FCOP — Force COP Watchdog Failure

TCON — Test Configuration Register

CONFIG — COP, ROM, EEPROM Enables

\$103F

	Bit 7	6	5	4	3	2	1	Bit 0
	0	0	0	0	NOSEC	NOCOP	ROMON	EEON
RESET:	0	0	0	0	—	—	—	—

Note

The bits of this register are implemented with EEPROM cells. Programming and erasing follow normal EEPROM procedures. The erased state of CONFIG is \$0F. A new value is not readable until after a subsequent reset sequence. CONFIG can only be programmed or erased in special modes.

NOSEC — EEPROM Security Disable

Refer to **Electrically Erasable Programmable Read-Only Memory (EEPROM)**.

NOCOP — COP System Disable

Refer to **Resets and Interrupts**.

ROMON — ROM Enable

In single-chip mode, ROMON is forced to one out of reset.

0 = 8K ROM removed from the memory map

1 = 8K ROM present in the memory map

EEON — EEPROM Enable

0 = EEPROM is removed from the memory map

1 = EEPROM is present in the memory map

The MC68HC11A8 has 3 reset vectors and 18 interrupt vectors. The reset vectors are as follows:

- $\overline{\text{RESET}}$, or Power-On
- COP Clock Monitor Fail
- COP Failure

The 8 interrupt vectors service 23 interrupt sources (3 non-maskable, 20 maskable). The 3 non-maskable interrupt vectors are as follows:

- Illegal Opcode Trap
- Software Interrupt
- XIRQ Pin (Pseudo Non-Maskable Interrupt)

The 20 maskable interrupt sources are subject to masking by a global interrupt mask, the I bit in the condition code register (CCR). In addition to the global I bit, all of these sources except the external interrupt ($\overline{\text{IRQ}}$) pin are controlled by local enable bits in control registers. Most interrupt sources in the M68HC11 have separate interrupt vectors. For this reason, there is usually no need for software to poll control registers to determine the cause of an interrupt. The maskable interrupt sources respond to a fixed priority relationship, except that any one source can be dynamically elevated to the highest priority position of any maskable source. Refer to the table of interrupt and reset vector assignments.

On-chip peripheral systems generate maskable interrupts that are recognized only if the I bit in the CCR is clear. Maskable interrupts are prioritized according to a default arrangement, but any one source can be elevated to the highest maskable priority position by the HPRIO register. The HPRIO register can be written at any time, provided the I bit in the CCR is set.

For some interrupt sources, such as the parallel I/O and SCI interrupts, the flags are automatically cleared during the course of responding to the interrupt requests. For example, the RDRF flag in the SCI system is cleared by the automatic clearing mechanism, which consists of a read of the SCI status register while RDRF is set, followed by a read of the SCI data register. The normal response to an RDRF interrupt request is to read the SCI status register to check for receive errors, then to read the received data from the SCI data register. These two steps satisfy the automatic clearing mechanism without requiring any special instructions.

The real-time interrupt (RTI) function generates hardware interrupts at a fixed periodic rate. These hardware interrupts provide a time reference signal for routines that measure real time. The routine notes the number of times a particular interrupt has occurred and multiplies that number by the predetermined subroutine execution time.

There are four RTI signal rates available in the MC68HC11A8. The MCU oscillator frequency and the value of two software-accessible control bits, RTR1 and RTR0, in the pulse accumulator control register (PACTL) determine these signal rates. Refer to **Main Timer** for more information about PACTL.

Interrupt and Reset Vector Assignments

Vector Address	Interrupt Source	CC Register Mask	Local Mask
FFC0, C1 — FFD4, D5	Reserved	—	—
FFD6, D7	SCI Serial System	I Bit	
	• SCI Transmit Complete		TCIE
	• SCI Transmit Data Register Empty		TIE
	• SCI Idle Line Detect		ILIE
	• SCI Receiver Overrun		RIE
	• SCI Receive Data Register Full		RIE
FFD8, D9	SPI Serial Transfer Complete	I Bit	SPIE
FFDA, DB	Pulse Accumulator Input Edge	I Bit	PAII
FFDC, DD	Pulse Accumulator Overflow	I Bit	PAOVI
FFDE, DF	Timer Overflow	I Bit	TOI
FFE0, E1	Timer Input Capture 4/Output Compare 5	I Bit	I4O5I
FFE3, E2	Timer Output Compare 4	I Bit	OC4I
FFE4, E5	Timer Output Compare 3	I Bit	OC3I
FFE6, E7	Timer Output Compare 2	I Bit	OC2I
FFE8, E9	Timer Output Compare 1	I Bit	OC1I
FFEA, EB	Timer Input Capture 3	I Bit	IC3
FFEC, ED	Timer Input Capture 2	I Bit	IC2I
FFEE, EF	Timer Input Capture 1	I Bit	IC1I
FFF0, F1	Real-Time Interrupt	I Bit	RTII
FFF2, F3	Parallel I/O Handshake	I Bit	STAI
	$\overline{\text{IRQ}}$ (External Pin)		None
FFF4, F5	$\overline{\text{XIRQ}}$ Pin	X Bit	None
FFF6, F7	Software Interrupt	None	None
FFF8, F9	Illegal Opcode Trap	None	None
FFFA, FB	COP Failure	None	NOCOP
FFFC, FD	COP Clock Monitor Fail	None	CME
FFFE, FF	$\overline{\text{RESET}}$	None	None

OPTION — System Configuration Options

\$1039

	Bit 7	6	5	4	3	2	1	Bit 0
	ADPU	CSEL	IRQE*	DLY*	CME	0	CR1*	CR0*
RESET:	0	0	0	1	0	0	0	0

*Can be written only once in first 64 cycles out of reset in normal modes, or any time in special modes.

ADPU — A/D Converter Power-up
Refer to **Analog-to-Digital Converter**.

CSEL — Clock Select
Refer to **Analog-to-Digital Converter**.

IRQE — $\overline{\text{IRQ}}$ Select Edge-Sensitive Only
0 = Low logic level recognition
1 = Falling edge recognition

DLY — Enable Oscillator Start-Up Delay on Exit from STOP
0 = No stabilization delay on exit from STOP
1 = Stabilization delay enabled on exit from STOP

CME — Clock Monitor Enable
0 = Clock monitor disabled; slow clocks can be used
1 = Slow or stopped clocks cause clock failure reset

CR1, CR0 — COP Timer Rate Select

CR [1:0]	Divide $E/2^{15}$ By	XTAL = 4.0 Mhz Timeout -0/+32.8 ms	XTAL = 8.0 MHz Timeout -0/+16.4 ms	XTAL = 12.0 MHz Timeout -0/+10.9 ms
00	1	32.768 ms	16.384 ms	10.923 ms
01	4	131.072 ms	65.536 ms	43.691 ms
10	16	524.288 ms	262.140 ms	174.76 ms
11	64	2.097 sec	1.049 sec	699.05 ms
	E =	1.0 MHz	2.0 MHz	3.0 MHz

COPRST — Arm/Reset COP Timer Circuitry

\$103A

	Bit 7	6	5	4	3	2	1	Bit 0
	7	6	5	4	3	2	1	0
RESET:	0	0	0	0	0	0	0	0

Write \$55 to COPRST to arm COP watchdog clearing mechanism. Write \$AA to COPRST to reset COP watchdog.

HPRIO — Highest Priority I-Bit Interrupt and Miscellaneous

\$103C

	Bit 7	6	5	4	3	2	1	Bit 0
	RBOOT	SMOD	MDA	IRV	PSEL3	PSEL2	PSEL1	PSEL0
RESET:	—	—	—	—	0	1	0	1

RBOOT — Read Bootstrap ROM Bits 7–4

Refer to **Operating Modes and Memory Maps**.

SMOD — Special Mode Select

Refer to **Operating Modes and Memory Maps**.

MDA — Mode Select A

Refer to **Operating Modes and Memory Maps**.

IRV — Internal Read Visibility

Refer to **Operating Modes and Memory Maps**.

PSEL3–PSEL0 — Priority Select Bits 3 through 0

Writable only while the I bit in the CCR is set (interrupts disabled). These bits select one interrupt source to be elevated above all other I-bit related sources.

PSEL [3:0]	Interrupt Source Promoted
0000	Timer Overflow
0001	Pulse Accumulator Overflow
0010	Pulse Accumulator Input Edge
0011	SPI Serial Transfer Complete
0100	SCI Serial System
0101	Reserved (Default to $\overline{\text{IRQ}}$)
0110	$\overline{\text{IRQ}}$ (External Pin or Parallel I/O)
0111	Real-Time Interrupt
1000	Timer Input Capture 1
1001	Timer Input Capture 2
1010	Timer Input Capture 3
1011	Timer Output Compare 1
1100	Timer Output Compare 2
1101	Timer Output Compare 3
1110	Timer Output Compare 4
1111	Timer Output Compare 5

CONFIG — COP, ROM, EEPROM Enables

\$103F

	Bit 7	6	5	4	3	2	1	Bit 0
	0	0	0	0	NOSEC	NOCOP	ROMON	EEON
RESET:	0	0	0	0	—	—	—	—

NOTE

The bits of this register are implemented with EEPROM cells. Programming and erasing follow normal EEPROM procedures. The erased state of CONFIG is \$0F. A new value is not readable until after a subsequent reset sequence. CONFIG can only be programmed or erased in special modes.

NOSEC — EEPROM Security Disable

Refer to **Electrically Erasable Programmable Read-Only Memory (EEPROM)**.

NOCOP — COP system disable

0 = COP enabled (forces reset on timeout)

1 = COP disabled (does not force reset on timeout)

ROMON — ROM Enable

Refer to **Operating Modes and Memory Maps**.

EEON — EEPROM Enable

Refer to **Operating Modes and Memory Maps**.

The 512 bytes of EEPROM in the MC68HC11A8 are located at \$B600 through \$B7FF. The EEON bit in CONFIG controls the presence or absence of the EEPROM in the memory map. When EEON = 1 (erased state), the EEPROM is enabled. When EEON = 0, the EEPROM is disabled and out of the memory map. EEON is reset to the value last programmed into CONFIG. An on-chip charge pump develops the high voltage required for programming and erasing. When the E clock is less than 1 MHz, select an internal clock. This drives the EEPROM charge pump by writing a one to the CSEL bit in the OPTION register.

The PPROG register controls the programming and erasing of the EEPROM. To erase the EEPROM, complete the following steps using the PPROG register:

1. Write to PPROG with the ERASE, EELAT, and appropriate BYTE and ROW bits set.
2. Write to the appropriate EEPROM address with any data. Row erase only requires a write to any location in the row. Bulk erase is accomplished by writing to any location in the array.
3. Write to PPROG with ERASE, EELAT, EEPGM, and the appropriate BYTE and ROW bits set.
4. Delay for 10 ms or more, as appropriate.
5. Clear the EEPGM bit in PPROG to turn off the high voltage.
6. Clear the PPROG register to reconfigure the EEPROM address and data buses for normal operation.

To program the EEPROM, complete the following steps using the PPROG register:

1. Write to PPROG with the EELAT bit set.
2. Write data to the desired address.
3. Write to PPROG with the EELAT and EEPGM bits set.
4. Delay for 10 ms or more, as appropriate.
5. Clear the EEPGM bit in PPROG to turn off the high voltage.
6. Clear the PPROG register to reconfigure the EEPROM address and data buses for normal operation.

PPROG — EEPROM Programming Control

\$103B

	Bit 7	6	5	4	3	2	1	Bit 0
	ODD	EVEN	0	BYTE	ROW	ERASE	EELAT	EEPGM
RESET:	0	0	0	0	0	0	0	0

ODD — Program Odd Rows in Half of EEPROM (TEST)

EVEN — Program Even Rows in Half of EEPROM (TEST)

BYTE — Byte/Other EEPROM Erase Mode

The BYTE bit overrides the ROW bit.

0 = Row or bulk erase mode is used

1 = Erase only one byte of EEPROM

ROW — Row/All EEPROM Erase Mode

The ROW bit is only valid when BYTE = 0.

0 = All 512 bytes of EEPROM are erased

1 = Erase only one 16-byte row of EEPROM

BYTE	ROW	Action
0	0	Bulk Erase (All 512 Bytes)
0	1	Row Erase (16 Bytes)
1	0	Byte Erase
1	1	Byte Erase

ERASE — Erase/Normal Control for EEPROM

- 0 = Normal read or program mode
- 1 = Erase mode

EELAT — EEPROM Latch Control

- 0 = EEPROM address and data bus configured for normal reads
- 1 = EEPROM address and data bus configured for programming or erasing

EEPGM — EEPROM Program Command

- 0 = Programming or erase voltage switched off to EEPROM array
- 1 = Programming or erase voltage switched on to EEPROM array

CONFIG — COP, ROM, EEPROM Enables

\$103F

	Bit 7	6	5	4	3	2	1	Bit 0
RESET:	0	0	0	0	NOSEC	NOCOP	ROMON	EEON

NOTE

The bits of this register are implemented with EEPROM cells. Programming and erasing follow normal EEPROM procedures. The erased state of CONFIG is \$0F. A new value is not readable until after a subsequent reset sequence. CONFIG can only be programmed or erased in special modes.

NOSEC — EEPROM Security Disable

NOSEC has no meaning unless the security mask option was specified before the MCU was manufactured.

- 0 = Security enabled (available as a mask option on MC68HC11A8 only)
- 1 = Security disabled

NOCOP — COP system disable

Refer to **Resets and Interrupts**.

ROMON — ROM Enable

Refer to **Operating Modes and Memory Maps**.

EEON — EEPROM Enable

- 0 = EEPROM is removed from the memory map
- 1 = EEPROM is present in the memory map

Input/Output

The MC68HC11A8 has up to 38 input/output lines, depending on the operating mode. Port A has three input-only pins, four output-only pins, and one bidirectional I/O pin. Port A shares functions with the timer system.

Port B is an 8-bit output-only port in single-chip modes and is the high-order address in expanded modes.

Port C is an 8-bit bidirectional port in single-chip modes and the multiplexed address and data bus in expanded modes.

Port D is a 6-bit bidirectional port that shares functions with the serial systems.

Port E is an 8-bit input-only port that shares functions with the A/D system.

Simple and full handshake input and output functions are available on ports B and C lines in single-chip mode. A description of the handshake functions follows.

In port B simple strobed output mode, the STRB output is pulsed for two E-clock periods each time there is a write to the PORTB register. The INVB bit in the PIOC register controls the polarity of STRB pulses.

In port C simple strobed input mode, port C levels are latched into the alternate port C latch (PORTCL) register on each assertion of the STRA input. STRA edge select, flag and interrupt enable bits are located in the PIOC register. Any or all of the port C lines can still be used as general purpose I/O while in strobed input mode.

Port C full handshake mode involves port C pins and the STRA and STRB lines. Input and output handshake modes are supported, and output handshake mode has a three-stated variation. STRA is an edge detecting input, and STRB is a handshake output. Control and enable bits are located in the PIOC register.

In full input handshake mode, the MCU uses STRB as a “ready” line to an external system. Port C logic levels are latched into PORTCL when the STRA line is asserted by the external system. The MCU then deasserts STRB. The MCU reasserts STRB after the PORTCL register is read. A mix of latched inputs, static inputs, and static outputs is allowed on port C, differentiated by the data direction bits and use of the PORTC and PORTCL registers.

In full output handshake mode, the MCU writes data to PORTCL, which in turn asserts the STRB output to indicate that data is ready. The external system reads port C (the STRB output) and asserts the STRA input to acknowledge that data has been received.

In the three-state variation of output handshake mode, lines intended as three-state handshake outputs are configured as inputs by clearing the corresponding DDRC bits. The MCU writes data to PORTCL and asserts STRB. The external system responds by activating the STRA input, which forces the MCU to drive the data in PORTCL out on all of the port C lines. This mode variation does not allow part of port C to be used for static inputs while other port C pins are being used for handshake outputs. Refer to the PIOC register description.

PORTA — Port A Data

\$1000

	Bit 7	6	5	4	3	2	1	Bit 0
	PA7	PA6	PA5	PA4	PA3	PA2	PA1	PA0
RESET:	HZ	0	0	0	0	HZ	HZ	HZ
Alt. Pin Func.:	PAI	OC2	OC3	OC4	OC5	IC1	IC2	IC3
And/or:	OC1	OC1	OC1	OC1	OC1	—	—	—

PIOC — Parallel I/O Control

\$1002

	Bit 7	6	5	4	3	2	1	Bit 0
	STAF	STAI	CWOM	HNDS	OIN	PLS	EGA	INVB
RESET:	0	0	0	0	0	U	1	1

STAF — Strobe A Interrupt Status Flag

Set when selected edge occurs on Strobe A. Cleared by PIOC read with STAF set followed by PORTCL read (simple strobed or full input handshake mode) or PORTCL write (output handshake mode).

STAI — Strobe A Interrupt Enable Mask

- 0 = STAF interrupts disabled
- 1 = STAF interrupts enabled

CWOM — Port C Wire-OR Mode (affects all eight port C pins)

- 0 = Port C outputs are normal CMOS outputs
- 1 = Port C outputs are open-drain outputs

HNDS — Handshake Mode

- 0 = Simple strobe mode
- 1 = Full input or output handshake mode

OIN — Output or Input Handshake Select

HNDS must be set to one for this bit to have meaning.

- 0 = Input handshake
- 1 = Output handshake

PLS — Pulse/Interlocked Handshake Operation

HNDS must be set to one for this bit to have meaning.

- 0 = Interlocked handshake
- 1 = Pulsed handshake (strobe B pulses high for two E-clock cycles)

EGA — Active Edge for Strobe A

- 0 = STRA falling edge selected
- 1 = STRA rising edge selected

INVB — Invert Strobe B

- 0 = Active level is logic zero
- 1 = Active level is logic one

Parallel I/O Control

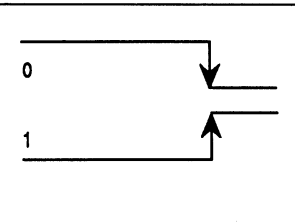
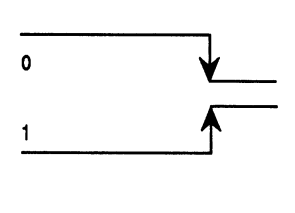
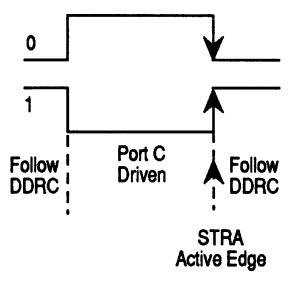
	STAF Clearing Sequence	HNDS	OIN	PLS	EGA	Port C	Port B
Simple strobed mode	Read PIOC with STAF=1 then read PORTCL	0	X	X		Inputs latched into PORTCL on any active edge on STRA	STRB pulses on writes to port B
Full input handshake	Read PIOC with STAF=1 then read PORTCL	1	0	0 = STRB active level 1 = STRB active pulse		Inputs latched into PORTCL on any active edge on STRA	Normal output port, unaffected in handshake modes
Full output handshake	Read PIOC with STAF=1 then write to PORTCL	1	1	0 = STRB active level 1 = STRB active pulse		Driven as outputs if STRA at active level, follows DDRC if STRA not at active level	Normal output port, unaffected in handshake modes

PORTC — Port C Data

\$1003

	Bit 7	6	5	4	3	2	1	Bit 0
	PC7	PC6	PC5	PC4	PC3	PC2	PC1	PC0
S. Chip or Boot:	PC7	PC6	PC5	PC4	PC3	PC2	PC1	PC0
RESET:	0	0	0	0	0	0	0	0
Expan. or Test:	A7/D7	A6/D6	A5/D5	A4/D4	A3/D3	A2/D2	A1/D1	A0/D0

NOTE

In single chip and boot modes, port C pins reset to high impedance inputs (DDRC registers are set to zero). In expanded and special test modes, port C is a multiplexed address/data bus and the port C register address is treated as an external memory location.

PORTB — Port B Data

\$1004

	Bit 7	6	5	4	3	2	1	Bit 0
	PB7	PB6	PB5	PB4	PB3	PB2	PB1	PB0
S. Chip or Boot:	PB7	PB6	PB5	PB4	PB3	PB2	PB1	PB0
RESET:	0	0	0	0	0	0	0	0
Expan. or Test:	A15	A14	A13	A12	A11	A10	A9	A8

PORTCL — Port C Latched

\$1005

	Bit 7	6	5	4	3	2	1	Bit 0
	PCL7	PCL6	PCL5	PCL4	PCL3	PCL2	PCL1	PCL0
RESET:	U	U	U	U	U	U	U	U

Writes affect port C pins. PORTCL is used in the handshake clearing mechanism. When an active edge occurs on the STRA pin, port C data is latched into the PORTCL register.

DDRC — Data Direction Register for Port C

\$1007

	Bit 7	6	5	4	3	2	1	Bit 0
	DDC7	DDC6	DDC5	DDC4	DDC3	DDC2	DDC1	DDC0
RESET:	0	0	0	0	0	0	0	0

DDC7–DDC0 — Data Direction Register for Port C

0 = Input
1 = Output

PORTD — Port D Data

\$1008

	Bit 7	6	5	4	3	2	1	Bit 0
	0	0	PD5	PD4	PD3	PD2	PD1	PD0
RESET:	0	0	0	0	0	0	0	0
Alt. Pin Func.:	—	—	\overline{SS}	SCK	MOSI	MISO	TxD	RxD

DDRD — Data Direction Register for Port D

\$1009

	Bit 7	6	5	4	3	2	1	Bit 0
	0	0	DDD5	DDD4	DDD3	DDD2	DDD1	DDD0
RESET:	0	0	0	0	0	0	0	0
Alt. Pin Func.:	—	—	PD5/ SS	PD4/ SCK	PD3/ MOSI	PD2/ MISO	PD1/ TxD	PD0/ RxD

DDD5–DDD0 — Data Direction for Port D

0 = Input
1 = Output

PORTE — Port E Data

\$100A

	Bit 7	6	5	4	3	2	1	Bit 0
	PE7	PE6	PE5	PE4	PE3	PE2	PE1	PE0
RESET:	U	U	U	U	U	U	U	U
Alt. Pin Func.:	AN7	AN6	AN5	AN4	AN3	AN2	AN1	AN0

PACTL — Pulse Accumulator Control

\$1026

	Bit 7	6	5	4	3	2	1	Bit 0
	DDRA7	PAEN	PAMOD	PEDGE	0	0	RTR1	RTR0
RESET:	0	0	0	0	0	0	0	0

DDRA7 — Data Direction for Port A Bit 7

0 = Input
1 = Output

PAEN — Pulse Accumulator System Enable
Refer to **Pulse Accumulator**.

PAMOD — Pulse Accumulator Mode
Refer to **Pulse Accumulator**.

PEDGE — Pulse Accumulator Edge Control
Refer to **Pulse Accumulator**.

RTR1, RTR0 — Real-Time Interrupt Rate
Refer to **Main Timer**.

The SCI, a universal asynchronous receiver transmitter (UART) serial communications interface, is one of two independent serial I/O subsystems in the MC68HC11A8. It has a standard NRZ format (one start, eight or nine data, and one stop bit) and several baud rates available. The SCI transmitter and receiver are independent, but use the same data format and bit rate.

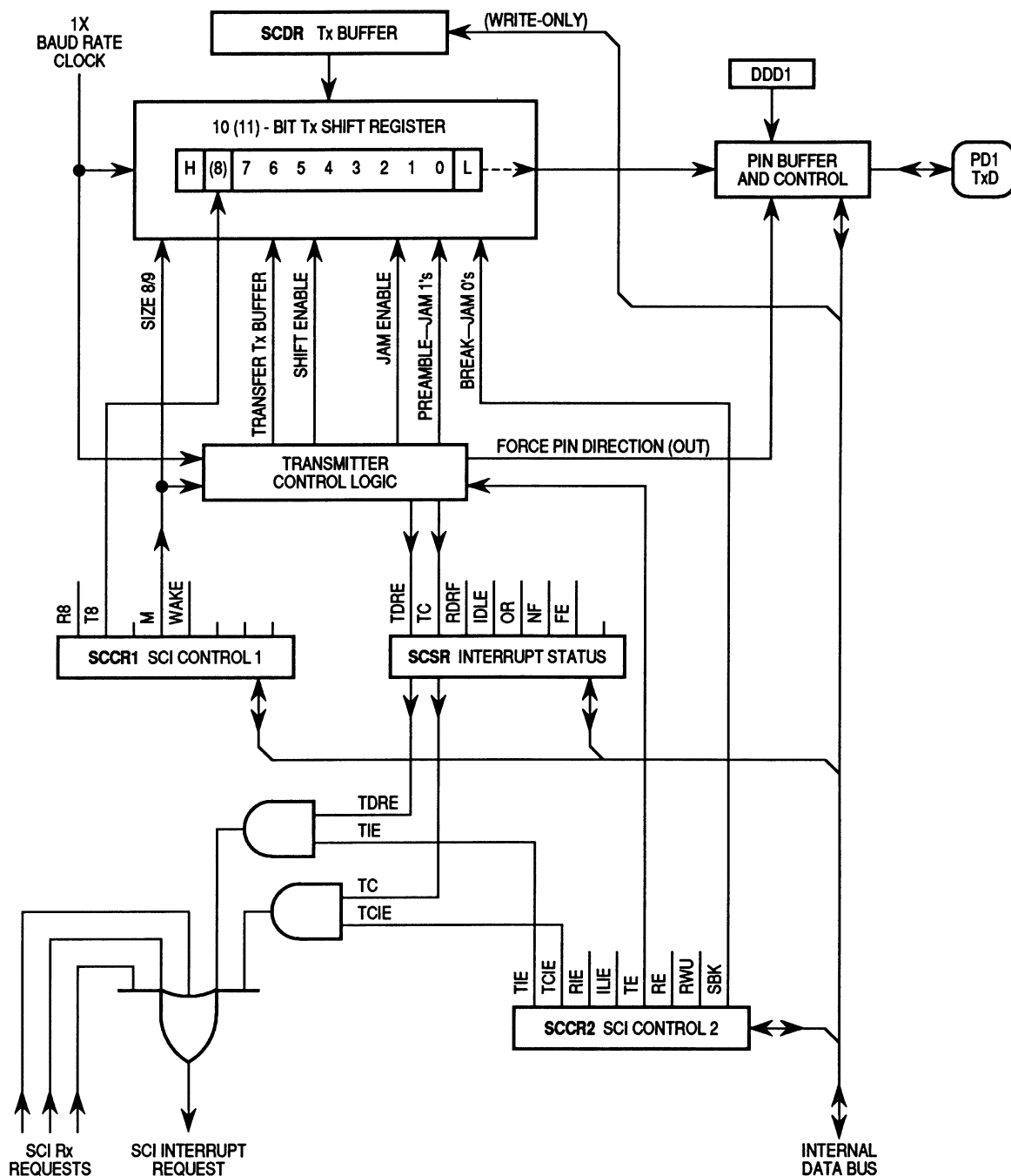

SCI Transmitter Block Diagram

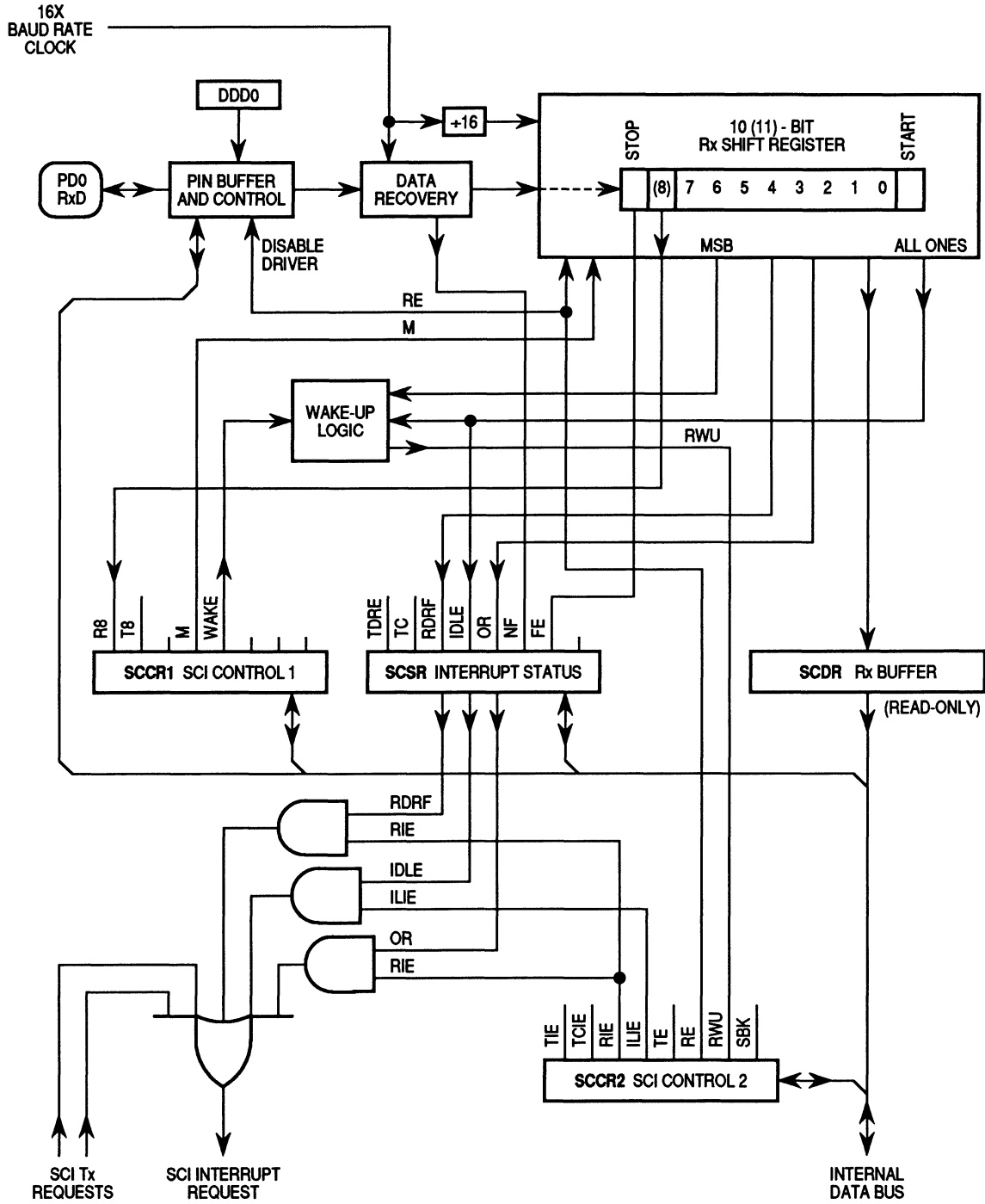

SCI Receiver Block Diagram

BAUD — Baud Rate

\$102B

	Bit 7	6	5	4	3	2	1	Bit 0
	TCLR	0	SCP1	SCP0	RCKB	SCR2	SCR1	SCR0
RESET:	0	0	0	0	0	U	U	U

TCLR — Clear Baud Rate Counters (TEST)

RCKB — SCI Baud Rate Clock Check (TEST)

SCP1, SCP0 — SCI Baud Rate Prescaler Selects

SCP[1:0]	Divide Internal Clock By	Crystal Frequency in MHz			
		4.0 MHz (Baud)	8.0 MHz (Baud)	10.0 MHz (Baud)	12.0 MHz (Baud)
00	1	62.50K	125.0K	156.25K	187.5K
01	3	20.83K	41.67K	52.08K	62.5K
10	4	15.625K	31.25K	38.4K	46.88K
11	13	4800	9600	12.02K	14.42K

SCR2, SCR1, and SCR0 — SCI Baud Rate Selects

Selects receiver and transmitter bit rate based on output from baud rate prescaler stage.

SCP[2:0]	Divide Prescaler By	Highest Baud Rate (Prescaler Output from Previous Table)		
		4800	9600	38.4K
000	1	4800	9600	38.4K
001	2	2400	4800	19.2K
010	4	1200	2400	9600
011	8	600	1200	4800
100	16	300	600	2400
101	32	150	300	1200
110	64	—	150	600
111	128	—	—	300

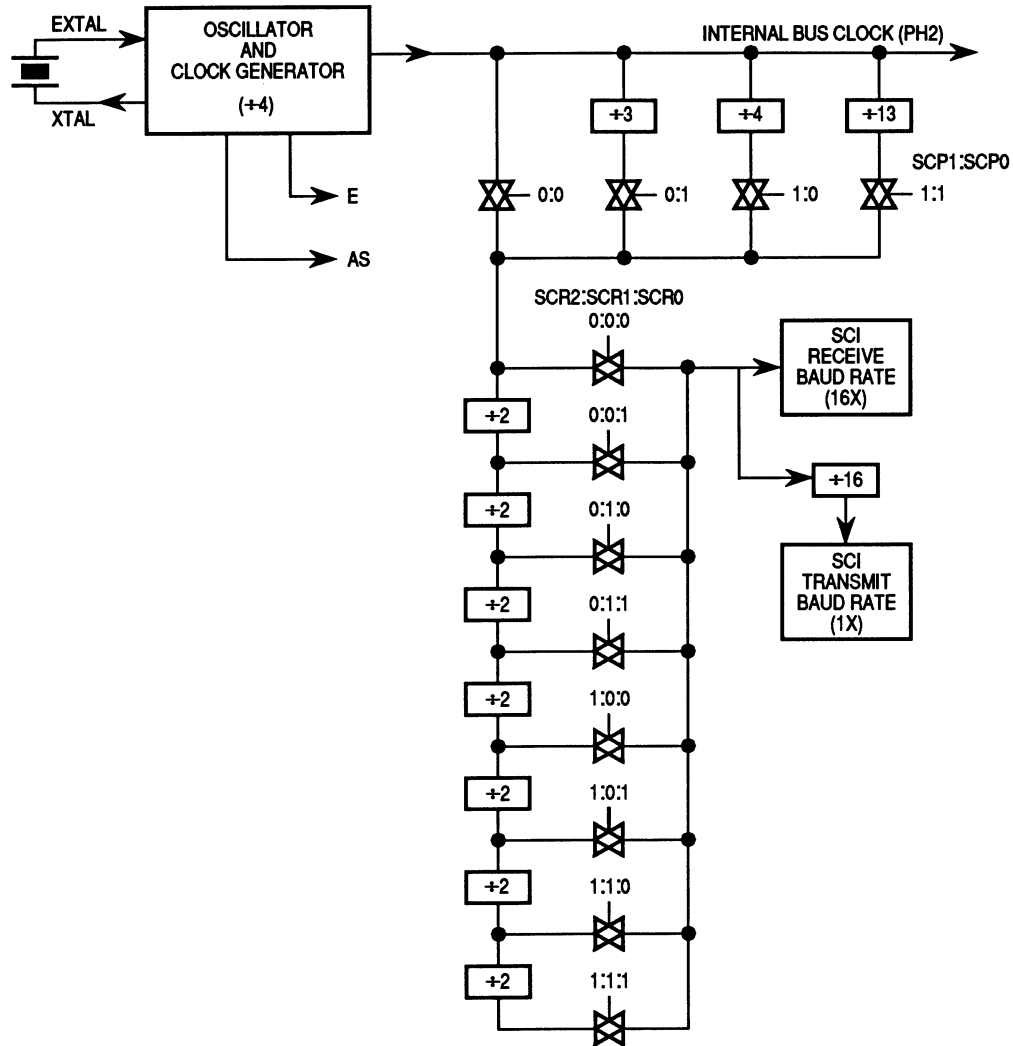

SCI Baud Rate Diagram

SCCR1 — SCI Control Register 1

\$102C

	Bit 7	6	5	4	3	2	1	Bit 0
	R8	T8	0	M	WAKE	0	0	0
RESET:	U	U	0	0	0	0	0	0

R8 — Receive Data Bit 8

If M bit is set, R8 stores ninth bit in receive data character.

T8 — Transmit Data Bit 8

If M bit is set, T8 stores ninth bit in transmit data character.

M — Mode (Select Character Format)

0 = Start bit, 8 data bits, 1 stop bit

1 = Start bit, 9 data bits, 1 stop bit

WAKE — Wake Up by Address Mark/Idle

0 = Wake up by IDLE line recognition

1 = Wake up by address mark (most significant data bit set)

SCCR2 — SCI Control Register 2

\$102D

	Bit 7	6	5	4	3	2	1	Bit 0
	TIE	TCIE	RIE	ILIE	TE	RE	RWU	SBK
RESET:	0	0	0	0	0	0	0	0

TIE — Transmit Interrupt Enable

0 = TDRE interrupts disabled

1 = SCI interrupt requested when TDRE status flag is set

TCIE — Transmit Complete Interrupt Enable

0 = TC interrupts disabled

1 = SCI interrupt requested if TC is set to one

RIE — Receiver Interrupt Enable

0 = RDRF and OR interrupts disabled

1 = SCI interrupt requested when RDRF flag or the OR status flag is set

ILIE — Idle Line Interrupt Enable

0 = IDLE interrupts disabled

1 = SCI interrupt requested when IDLE status flag is set

TE — Transmitter Enable

0 = Transmitter disabled

1 = Transmitter enabled

RE — Receiver Enable

0 = Receiver disabled

1 = Receiver enabled

Receiver Wake Up Control

- 0 = Normal SCI receiver
- 1 = Wake up enabled and receiver interrupts inhibited

SBK — Send Break

- 0 = Break generator off
- 1 = Break codes generated as long as SBK is set to one

SCSR — SCI Status Register

\$102E

	Bit 7	6	5	4	3	2	1	Bit 0
	TDRE	TC	RDRF	IDLE	OR	NF	FE	0
RESET:	1	1	0	0	0	0	0	0

TDRE — Transmit Data Register Empty Flag

Set if transmit data can be written to SCDR; if TDRE is zero, transmit data register is busy. Cleared by SCSR read with TDRE set followed by SCDR write.

TC — Transmit Complete Flag

Set if transmitter is idle (no data, preamble, or break transmission in progress). Cleared by SCSR read with TC set followed by SCDR write.

RDRF — Receive Data Register Full Flag

Set if a received character is ready to be read from SCDR. Cleared by SCSR read with RDRF set followed by SCDR read.

IDLE — Idle Line Detected Flag

Set if the RxD line is idle. IDLE flag is inhibited when RWU is set to one. Cleared by SCSR read with IDLE set followed by SCDR read. Once cleared, IDLE is not set again until the RxD line has been active and becomes idle again.

OR — Overrun Error Flag

Set if a new character is received before a previously received character is read from SCDR. Cleared by SCSR read with OR set followed by SCDR read.

NF — Noise Error Flag

Set if majority sample logic detects anything other than a unanimous decision. Cleared by SCSR read with NF set followed by SCDR read.

FE — Framing Error

Set if a 0 is detected where a stop bit was expected. Cleared by SCSR read with FE set followed by SCDR read.

SCDR — SCI Data Register

\$102F

	Bit 7	6	5	4	3	2	1	Bit 0
	R7/T7	R6/T6	R5/T5	R4/T4	R3/T3	R2/T2	R1/T1	R0/T0
RESET:	U	U	U	U	U	U	U	U

NOTE

Receive and transmit are double buffered. Reads access the receive data buffer and writes access the transmit data buffer.

The SPI is one of two independent serial communications subsystems that allow the MCU to communicate synchronously with peripheral devices and other microprocessors. Data rates can be as high as one half of the E-clock rate when configured as master, and as fast as the E clock when configured as slave.

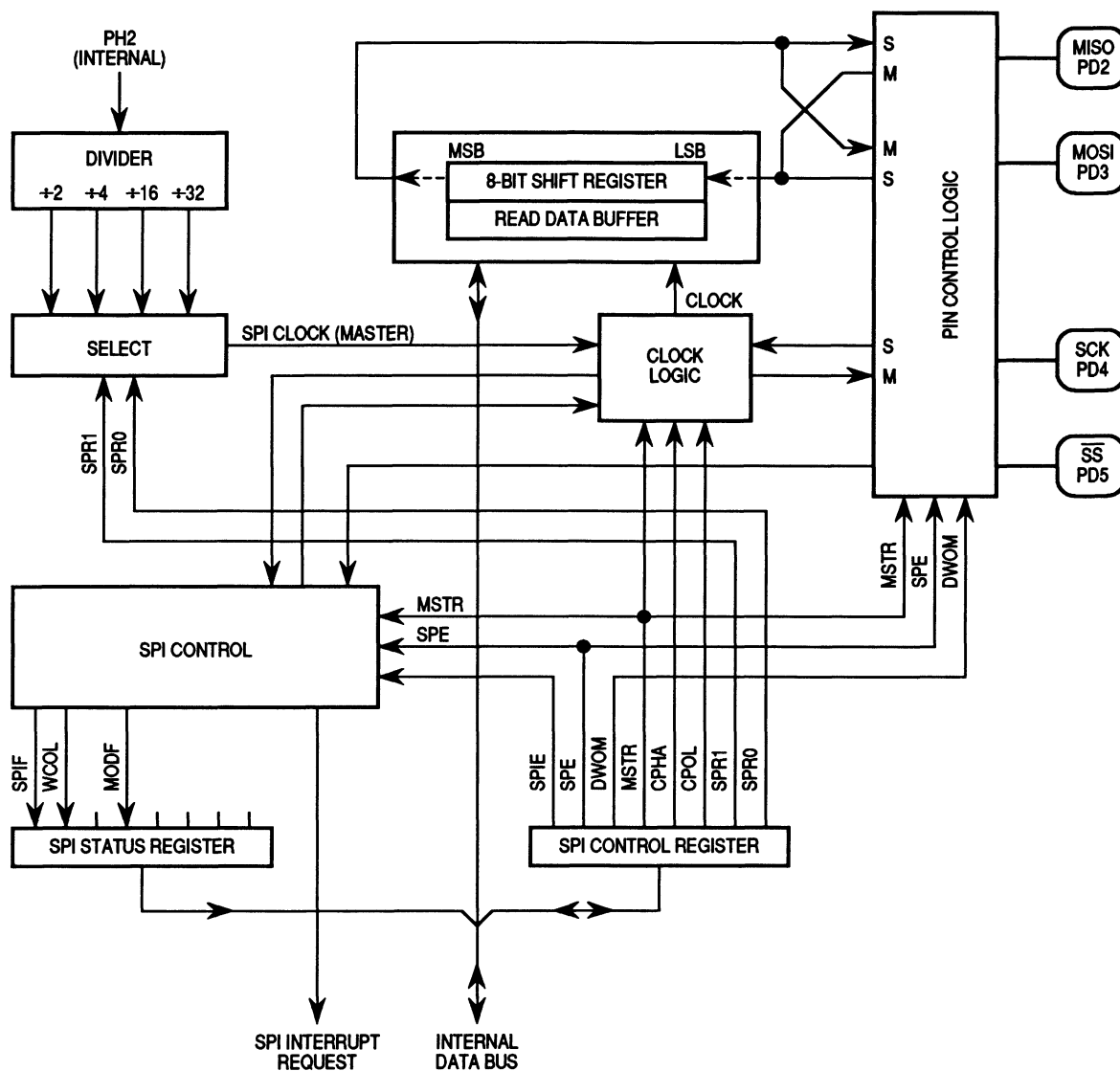

SPI Block Diagram

DDRD — Data Direction Register for Port D

\$1009

	Bit 7	6	5	4	3	2	1	Bit 0
	0	0	DDD5	DDD4	DDD3	DDD2	DDD1	DDD0
RESET:	0	0	0	0	0	0	0	0
Alt. Pin Func.:	—	—	PD5/ SS	PD4/ SCK	PD3/ MOSI	PD2/ MISO	PD1/ TxD	PD0/ RxD

DDD5–DDD0 — Data Direction for Port D

When DDRD bit 5 is zero and MSTR = 1 in SPCR, PD5/SS is a general-purpose output and mode fault logic is disabled.

- 0 = Input
- 1 = Output

SPCR — Serial Peripheral Control Register

\$1028

	Bit 7	6	5	4	3	2	1	Bit 0
	SPIE	SPE	DWOM	MSTR	CPOL	CPHA	SPR1	SPR0
RESET:	0	0	0	0	0	1	U	U

SPIE — Serial Peripheral Interrupt Enable

- 0 = SPI interrupts disabled
- 1 = SPI interrupts enabled

SPE — Serial Peripheral System Enable

- 0 = SPI off
- 1 = SPI on

DWOM — Port D Wired-OR Mode

DWOM affects all six port D pins.
0 = Normal CMOS outputs
1 = Open-drain outputs

MSTR — Master Mode Select

- 0 = Slave mode
- 1 = Master mode

CPOL, CPHA — Clock Polarity, Clock Phase

Refer to SPI Transfer Format.

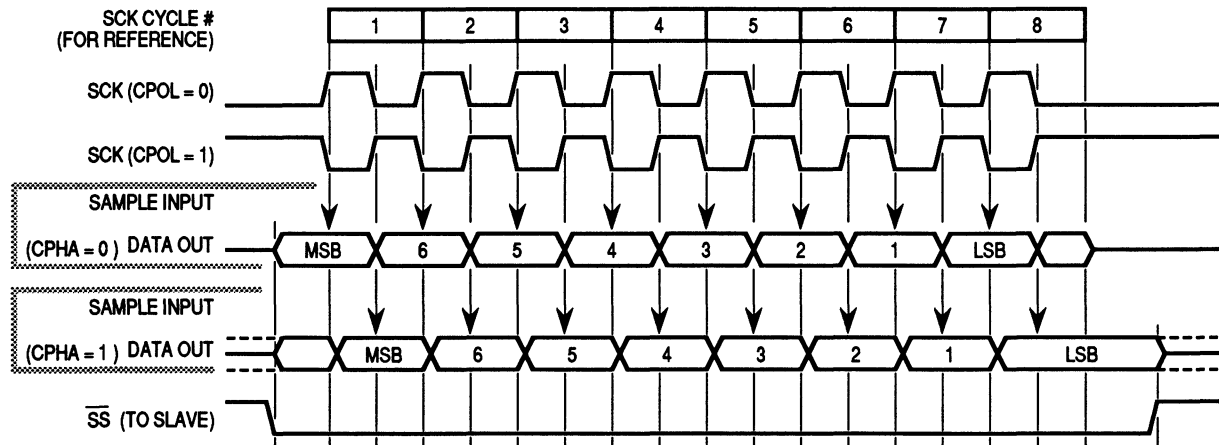

SPI Transfer Format

SPR1 and SPR0 — SPI Clock Rate Selects

SPR [1:0]	E-Clock Divide By	Frequency at E = 2 MHz (Baud)
00	2	1.0 MHz
01	4	500 kHz
10	16	125 kHz
11	32	62.5 kHz

SPSR — Serial Peripheral Status Register

\$1029

Bit 7	6	5	4	3	2	1	Bit 0
SPIF	WCOL	0	MODF	0	0	0	0

RESET: 0 0 0 0 0 0 0 0

SPIF — SPI Transfer Complete Flag

Set when an SPI transfer is complete. Cleared by reading SPSR with SPIF set followed by SPDR access.

WCOL — Write Collision

Set when SPDR is written while transfer is in progress. Cleared by SPSR with WCOL set followed by SPDR access.

MODF — Mode Fault (A Mode Fault Terminates SPI Operation)

Set when SS is pulled low while MSTR = 1. Cleared by SPSR read with MODF set followed by SPCR write.

SPDR — SPI Data Register

\$102A

Bit 7	6	5	4	3	2	1	Bit 0
Bit 7	6	5	4	3	2	1	Bit 0

NOTE

SPI is double buffered in, single buffered out.

The main timer is based on a free-running 16-bit counter with a four-stage programmable prescaler. A timer overflow function allows software to extend the system's timing capability beyond the counter's 16-bit range.

The timer has three channels of input capture and five channels of output compare.

Refer to the following table for a summary of crystal-related frequencies and periods.

Timer Summary

Control Bits	XTAL Frequencies			
	4.0 MHz	8.0 MHz	12.0 MHz	Other Rates
	1.0 MHz	2.0 MHz	3.0 MHz	(E)
	1000 ns	500 ns	333 ns	(1/E)
PR[1:0]	Main Timer Count Rates			
0 0 1 count — overflow —	1.0 μ s 65.536 ms	500 ns 32.768 ms	333 ns 21.845 ms	(E/1) (E/2 ¹⁶)
0 1 1 count — overflow —	4.0 μ s 262.14 ms	2.0 μ s 131.07 ms	1.333 μ s 87.381 ms	(E/4) (E/2 ¹⁸)
1 0 1 count — overflow —	8.0 μ s 524.29 ms	4.0 μ s 262.14 ms	2.667 μ s 174.76 ms	(E/8) (E/2 ¹⁹)
1 1 1 count — overflow —	16.0 μ s 1.049 s	8.0 μ s 524.29 ms	5.333 μ s 349.52 ms	(E/16) (E/2 ²⁰)
RTR[1:0]	Periodic (RTI) Interrupt Rates			
0 0	8.192 ms	4.096 ms	2.731 ms	(E/2 ¹³)
0 1	16.384 ms	8.192 ms	5.461 ms	(E/2 ¹⁴)
1 0	32.768 ms	16.384 ms	10.923 ms	(E/2 ¹⁵)
1 1	65.536 ms	32.768 ms	21.845 ms	(E/2 ¹⁶)

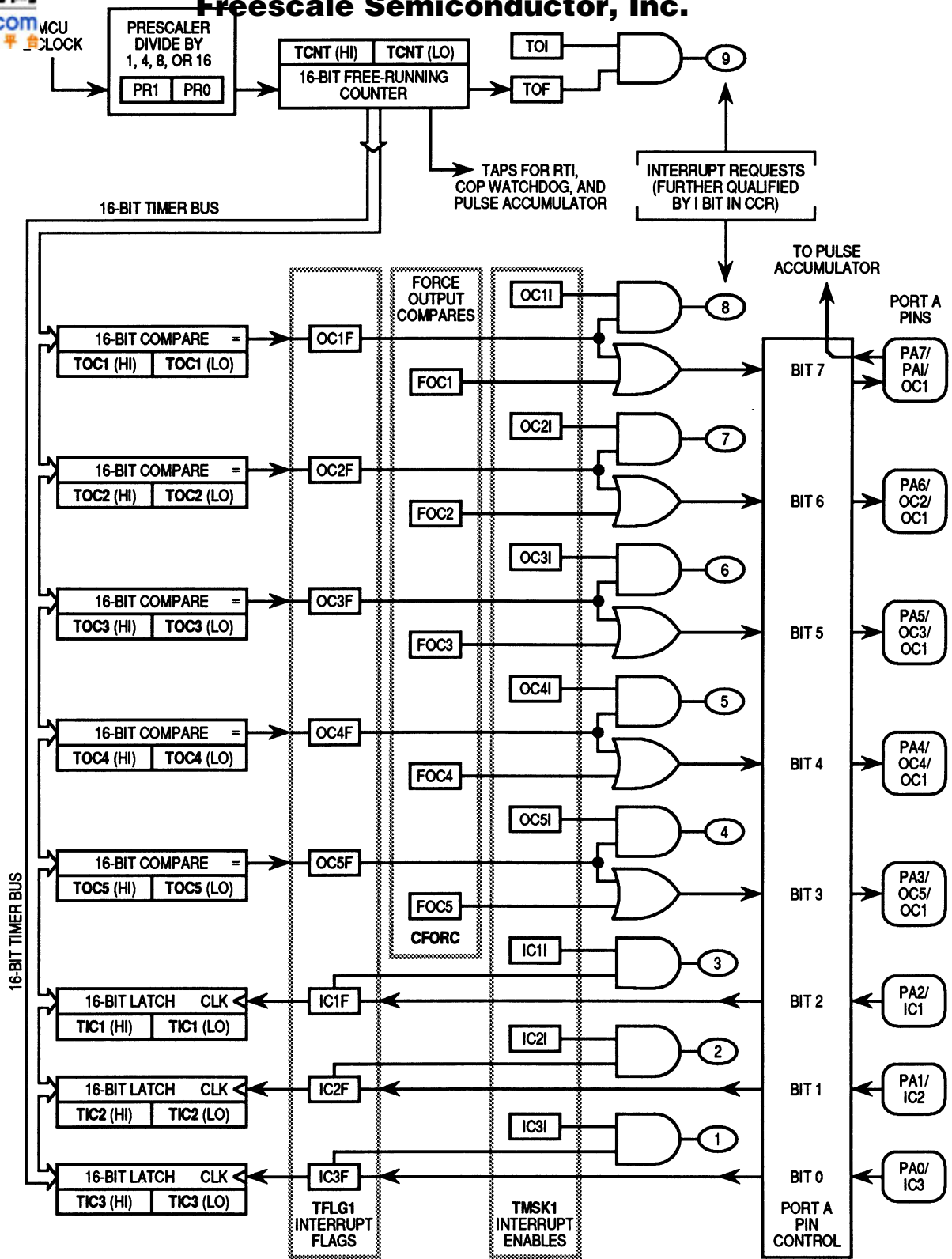

Main Timer

NOTE: Port A pin actions are controlled by OC1M, OC1D, PACTL, TCTL1, and TCTL2 registers.

CFORC — Timer Compare Force

\$100B

	Bit 7	6	5	4	3	2	1	Bit 0
	FOC1	FOC2	FOC3	FOC4	FOC5	0	0	0
RESET:	0	0	0	0	0	0	0	0

FOC5–FOC1 — Write ones to Force Compare(s)

0 = Not affected

1 = Output compare x action occurs, but OCxF flag bit not set

OC1M — Output Compare 1 Mask

\$100C

	Bit 7	6	5	4	3	2	1	Bit 0
	OC1M7	OC1M6	OC1M5	OC1M4	OC1M3	0	0	0
RESET:	0	0	0	0	0	0	0	0

Set bit(s) to enable OC1 to control corresponding pin(s) of port A.

OC1D — Output Compare 1 Data

\$100D

	Bit 7	6	5	4	3	2	1	Bit 0
	OC1D7	OC1D6	OC1D5	OC1D4	OC1D3	0	0	0
RESET:	0	0	0	0	0	0	0	0

If OC1Mx is set, data in OC1Dx is output to port A bit x on successful OC1 compares.

TCNT — Timer Counter

\$100E, \$100F

\$100E	Bit 15	14	13	12	11	10	9	Bit 8	High	TCNT
\$100F	Bit 7	6	5	4	3	2	1	Bit 0	Low	

TCNT resets to \$0000. In normal modes, TCNT is read-only.

TIC1–TIC3 — Timer Input Capture

\$1010–\$1015

\$1010	Bit 15	14	13	12	11	10	9	Bit 8	High	TIC1
	Bit 7	6	5	4	3	2	1	Bit 0		
\$1012	Bit 15	14	13	12	11	10	9	Bit 8	High	TIC2
	Bit 7	6	5	4	3	2	1	Bit 0		
\$1014	Bit 15	14	13	12	11	10	9	Bit 8	High	TIC3
	Bit 7	6	5	4	3	2	1	Bit 0		

TICx not affected by reset.

TOC1–TOC5 — Timer Output Compare

\$1016–\$101F

\$1016	Bit 15	14	13	12	11	10	9	Bit 8	High	TOC1
	Bit 7	6	5	4	3	2	1	Bit 0		
\$1018	Bit 15	14	13	12	11	10	9	Bit 8	High	TOC2
	Bit 7	6	5	4	3	2	1	Bit 0		
\$101A	Bit 15	14	13	12	11	10	9	Bit 8	High	TOC3
	Bit 7	6	5	4	3	2	1	Bit 0		
\$101C	Bit 15	14	13	12	11	10	9	Bit 8	High	TOC4
	Bit 7	6	5	4	3	2	1	Bit 0		
\$101E	Bit 15	14	13	12	11	10	9	Bit 8	High	TOC5
	Bit 7	6	5	4	3	2	1	Bit 0		

All TOCx register pairs reset to ones (\$FFFF).

TCTL1 — Timer Control 1

\$1020

	Bit 7	6	5	4	3	2	1	Bit 0
	OM2	OL2	OM3	OL3	OM4	OL4	OM5	OL5
RESET:	0	0	0	0	0	0	0	0

OM2–OM5 — Output Mode

OL2–OL5 — Output Level

OMx	OLx	Action Taken on Successful Compare
0	0	Timer disconnected from output pin logic
0	1	Toggle OCx output line
1	0	Clear OCx output line to 0
1	1	Set OCx output line to 1

TCTL2 — Timer Control 2

\$1021

	Bit 7	6	5	4	3	2	1	Bit 0
	—	—	EDG1B	EDG1A	EDG2B	EDG2A	EDG3B	EDG3A
RESET:	0	0	0	0	0	0	0	0

Timer Control Configuration

EDGxB	EDGxA	Configuration
0	0	Capture disabled
0	1	Capture on rising edges only
1	0	Capture on falling edges only
1	1	Capture on any edge

TMSK1 — Timer Interrupt Mask 1

\$1022

	Bit 7	6	5	4	3	2	1	Bit 0
	OC1I	OC2I	OC3I	OC4I	OC5I	IC1I	IC2I	IC3I
RESET:	0	0	0	0	0	0	0	0

OC1I–OC5I — Output Compare x Interrupt Enable

If the OCxI enable bit is set when the OCxF flag bit is set, a hardware interrupt sequence is requested.

IC1I–IC3I — Input Capture x Interrupt Enable

If the ICxI enable bit is set when the ICxF flag bit is set, a hardware interrupt sequence is requested.

NOTE

Bits in TMSK1 correspond bit for bit with flag bits in TFLG1. Ones in TMSK1 enable the corresponding interrupt sources.

TFLG1 — Timer Interrupt Flag 1

\$1023

	Bit 7	6	5	4	3	2	1	Bit 0
	OC1F	OC2F	OC3F	OC4F	OC5F	IC1F	IC2F	IC3F
RESET:	0	0	0	0	0	0	0	0

Clear flags by writing a one to the corresponding bit position(s).

OC1F–OC5F — Output Compare x Flag

Set each time the counter matches output compare x value.

IC1F–IC3F — Input Capture x Flag

Set each time a selected active edge is detected on the ICx input line.

TMSK2 — Timer Interrupt Mask 2

\$1024

	Bit 7	6	5	4	3	2	1	Bit 0
	TOI	RTII	PAOVI	PAII	0	0	PR1	PRO
RESET:	0	0	0	0	0	0	0	0

TOI — Timer Overflow Interrupt Enable

- 0 = TOF interrupts disabled
- 1 = Interrupt requested when TOF is set to one

RTII — Real-Time Interrupt Enable

- 0 = RTIF interrupts disabled
- 1 = Interrupt requested when RTIF is set to one

Refer to **Pulse Accumulator**.

PAIE — Pulse Accumulator Input Edge Interrupt Enable
 Refer to **Pulse Accumulator**.

NOTE

Bits in TMSK2 correspond bit for bit with flag bits in TFLG2. Ones in TMSK2 enable the corresponding interrupt sources.

PR1 and PR0 — Timer Prescaler Select

In normal modes, PR1 and PR0 can only be written once, and the write must be within 64 cycles after reset. Refer to **Timer Summary** for specific timing values.

PR[1:0]	Prescaler
0 0	1
0 1	4
1 0	8
1 1	16

TFLG2 — Timer Interrupt Flag 2

\$1025

	Bit 7	6	5	4	3	2	1	Bit 0
	TOF	RTIF	PAOVF	PAIF	0	0	0	0
RESET:	0	0	0	0	0	0	0	0

Clear flags by writing a one to the corresponding bit position(s).

TOF — Timer Overflow Flag

Set when TCNT changes from \$FFFF to \$0000.

RTIF — Real-Time (Periodic) Interrupt Flag

Set periodically. Refer to RTR[1:0] bits in PACTL register.

PAOVF — Pulse Accumulator Overflow Interrupt Flag

Refer to **Pulse Accumulator**.

PAIF — Pulse Accumulator Input Edge Interrupt Flag

Refer to **Pulse Accumulator**.

PACTL — Pulse Accumulator Control

\$1026

	Bit 7	6	5	4	3	2	1	Bit 0
	DDRA7	PAEN	PAMOD	PEDGE	0	0	RTR1	RTR0
RESET:	0	0	0	0	0	0	0	0

DDRA7 — Data Direction for Port A Bit 7

Refer to **Parallel I/O**.

PAEN — Pulse Accumulator Enable

Refer to **Pulse Accumulator**.

PAMOD — Pulse Accumulator Mode Select

Refer to **Pulse Accumulator**.

PEDGE — Pulse Accumulator Edge Select

Refer to **Pulse Accumulator**.

RTR [1:0] — Real-Time Interrupt (RTI) Rate

Real-Time Interrupt Rates

RTR[1:0]	Divide E By	XTAL = 4.0 MHz	XTAL = 8.0 MHz	XTAL = 12.0 MHz
00	2^{13}	8.19 ms	4.096 ms	2.731 ms
01	2^{14}	16.38 ms	8.192 ms	5.461 ms
10	2^{15}	32.77 ms	16.384 ms	10.923 ms
11	2^{16}	65.54 ms	32.768 ms	21.845 ms
	E =	1.0 MHz	2.0 MHz	3.0 MHz

TMSK2 — Timer Interrupt Mask 2

\$1024

	Bit 7	6	5	4	3	2	1	Bit 0
	TOI	RTII	PAOVI	PAII	0	0	PR1	PR0
RESET:	0	0	0	0	0	0	0	0

TOI — Timer Overflow Interrupt Enable
Refer to **Main Timer**.

RTII — Real-Time Interrupt Enable
Refer to **Main Timer**.

PAOVI — Pulse Accumulator Overflow Interrupt Enable
0 = PAOVF interrupts disabled
1 = Interrupt requested when RTIF is set to one

PAII — Pulse Accumulator Input Edge Interrupt Enable
0 = PAIF interrupts disabled
1 = Interrupt requested when PAIF is set to one

PR1, PR0 — Timer Prescaler Select
Refer to **Main Timer**.

NOTE

Bits in TMSK2 correspond bit for bit with flag bits in TFLG2. Ones in TMSK2 enable the corresponding interrupt sources.

TFLG2 — Timer Interrupt Flag 2

\$1025

	Bit 7	6	5	4	3	2	1	Bit 0
	TOF	RTIF	PAOVF	PAIF	0	0	0	0
RESET:	0	0	0	0	0	0	0	0

Clear flags by writing a one to the corresponding bit position(s).

TOF — Timer Overflow Flag
Refer to **Main Timer**.

RTIF — Real-Time Interrupt Flag
Refer to **Main Timer**.

PAOVF — Pulse Accumulator Overflow Flag
Set when PACNT changes from \$FF to \$00.

PAIF — Pulse Accumulator Input Edge Flag
Set each time a selected active edge is detected on the PAI input line.

PACTL — Pulse Accumulator Control

\$1026

	Bit 7	6	5	4	3	2	1	Bit 0
	DDRA7	PAEN	PAMOD	PEDGE	0	0	RTR1	RTR0
RESET:	0	0	0	0	0	0	0	0

DDRA7 — Data Direction for Port A Bit 7

Refer to **Parallel I/O**.

PAEN — Pulse Accumulator System Enable

0 = Pulse Accumulator disabled

1 = Pulse Accumulator enabled

PAMOD — Pulse Accumulator Mode

0 = Event counter

1 = Gated time accumulation

PEDGE — Pulse Accumulator Edge Control

PAMOD	PEDGE	Action on Clock
0	0	PAI falling edge increments the counter
0	1	PAI rising edge increments the counter
1	0	A zero on PAI inhibits counting
1	1	A one on PAI inhibits counting

RTR1 and RTR0 — Real-Time Interrupt (RTI) Rate

Refer to **Main Timer**.

PACNT — Pulse Accumulator Counter

\$1027

Bit 7	6	5	4	3	2	1	Bit 0
Bit 7	6	5	4	3	2	1	Bit 0

Readable and writable.

The A/D converter system uses an all capacitive charge redistribution technique to convert analog signals to digital values. The MC68HC11A8 A/D system is an 8-channel, 8-bit, multiplexed-input, successive-approximation converter and is accurate to ± 1 least significant bit (LSB). It does not require external sample and hold circuits because of the type of charge redistribution technique used.

Dedicated lines V_{RH} and V_{RL} provide the reference supply voltage inputs. Refer to the A/D converter block diagram.

A multiplexer allows the single A/D converter to select one of 16 analog signals, as shown in the ADCTL register description.

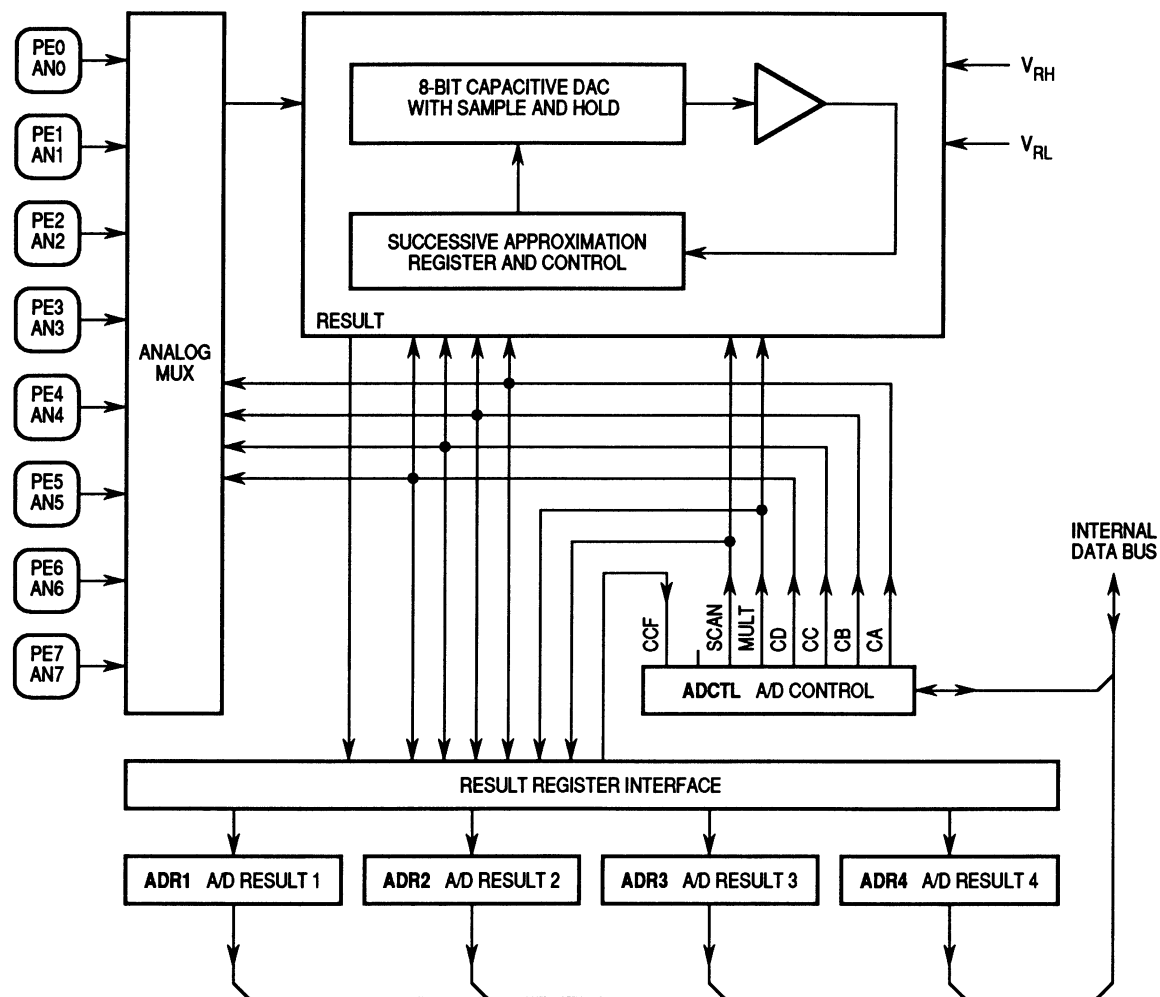

A/D Converter Block Diagram

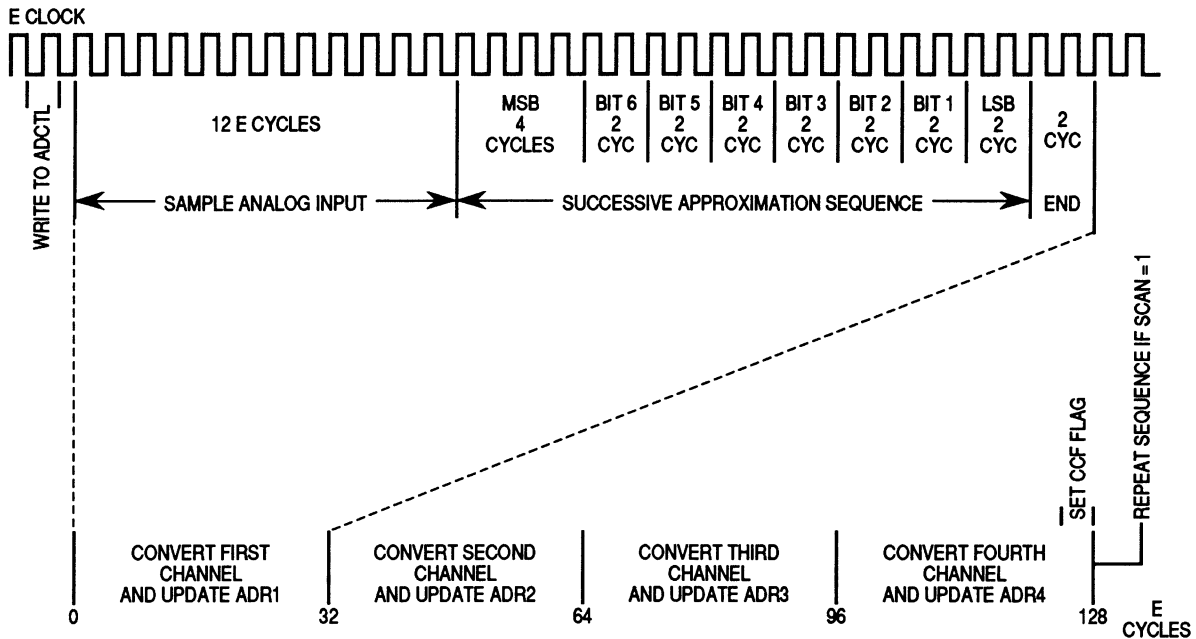

A/D Conversion Sequence

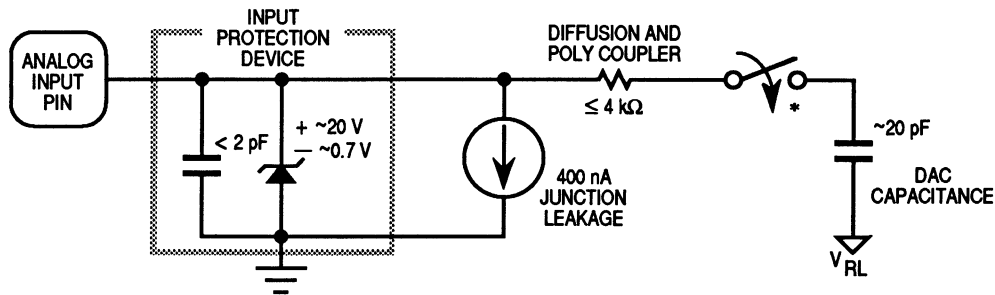

*This analog switch is closed only during the 12-cycle sample time.

Electrical Model of an Analog Input Pin (Sample Mode)

ADCTL — A/D Control/Status

\$1030

	Bit 7	6	5	4	3	2	1	Bit 0
	CCF	0	SCAN	MULT	CD	CC	CB	CA
RESET:	U	0	U	U	U	U	U	U

CCF — Conversions Complete Flag

Set after an A/D conversion cycle. Cleared when ADCTL is written.

SCAN — Continuous Scan Control

0 = Do four conversions and stop

1 = Convert four channels in selected group continuously

MULT — Multiple Channel/Single Channel Control

0 = Convert single channel selected

1 = Convert four channels in selected group

CD–CA — Channel Select D through A

A/D Converter Channel Assignments

Channel Select Control Bits				Channel Signal	Result in ADRx if MULT = 1
CD	CC	CB	CA		
0	0	0	0	AN0	ADR1
0	0	0	1	AN1	ADR2
0	0	1	0	AN2	ADR3
0	0	1	1	AN3	ADR4
0	1	0	0	AN4*	ADR1
0	1	0	1	AN5*	ADR2
0	1	1	0	AN6*	ADR3
0	1	1	1	AN7*	ADR4
1	0	X	X	Reserved	ADR1–ADR4
1	1	0	0	VRH**	ADR1
1	1	0	1	VRL**	ADR2
1	1	1	0	(VRH)/2**	ADR3
1	1	1	1	Reserved**	ADR4

*Not available in 48-pin package

** Used for factory testing

ADR1-ADR4 — A/D Results

\$1031-\$1034

	Bit 7	6	5	4	3	2	1	Bit 0	
\$1031	Bit 7	6	5	4	3	2	1	Bit 0	ADR1
\$1032	Bit 7	6	5	4	3	2	1	Bit 0	ADR2
\$1033	Bit 7	6	5	4	3	2	1	Bit 0	ADR3
\$1034	Bit 7	6	5	4	3	2	1	Bit 0	ADR4

Analog Input to 8-Bit Result Translation Table

	Bit 7	6	5	4	3	2	1	Bit 0
% (1)	50%	25%	12.5%	6.25%	3.12%	1.56%	0.78%	0.39%
Volts (2)	2.500	1.250	0.625	0.3125	0.1562	0.0781	0.0391	0.0195

(1) % of $V_{RH}-V_{RL}$

(2) $V_{RL} = 0.0\text{ V}; V_{RH} = 5.0\text{ V}$

OPTION — System Configuration Options

\$1039

	Bit 7	6	5	4	3	2	1	Bit 0
	ADPU	CSEL	IRQE*	DLY*	CME	0	CR1*	CR0*

RESET: 0 0 0 1 0 0 0 0

*Can be written only once in first 64 cycles out of reset in normal modes, or any time in special modes.

ADPU — A/D Power Up

- 0 = A/D Converter powered down
- 1 = A/D Converter powered up

CSEL — Clock Select

- 0 = A/D and EEPROM use system E clock
- 1 = A/D and EEPROM use internal RC clock

IRQE — $\overline{\text{IRQ}}$ Select Edge Sensitive Only

Refer to **Resets and Interrupts**.

DLY — Enable Oscillator Start-Up Delay on Exit from STOP

Refer to **Resets and Interrupts**.

CME — Clock Monitor Enable

Refer to **Resets and Interrupts**.

CR1, CR0 — COP Timer Rate Select

Refer to **Resets and Interrupts**.

Home Page:

www.freescale.com

email:

support@freescale.com

USA/Europe or Locations Not Listed:

Freescale Semiconductor
Technical Information Center, CH370
1300 N. Alma School Road
Chandler, Arizona 85224
(800) 521-6274
480-768-2130

support@freescale.com

Europe, Middle East, and Africa:

Freescale Halbleiter Deutschland GmbH
Technical Information Center
Schatzbogen 7
81829 Muenchen, Germany
+44 1296 380 456 (English)
+46 8 52200080 (English)
+49 89 92103 559 (German)
+33 1 69 35 48 48 (French)
support@freescale.com

Japan:

Freescale Semiconductor Japan Ltd.
Headquarters
ARCO Tower 15F
1-8-1, Shimo-Meguro, Meguro-ku
Tokyo 153-0064, Japan
0120 191014
+81 2666 8080
support.japan@freescale.com

Asia/Pacific:

Freescale Semiconductor Hong Kong Ltd.
Technical Information Center
2 Dai King Street
Tai Po Industrial Estate,
Tai Po, N.T., Hong Kong
+800 2666 8080
support.asia@freescale.com

For Literature Requests Only:

Freescale Semiconductor
Literature Distribution Center
P.O. Box 5405
Denver, Colorado 80217
(800) 441-2447
303-675-2140
Fax: 303-675-2150
LDCForFreescaleSemiconductor
@hibbertgroup.com

RoHS-compliant and/or Pb-free versions of Freescale products have the functionality and electrical characteristics of their non-RoHS-compliant and/or non-Pb-free counterparts. For further information, see <http://www.freescale.com> or contact your Freescale sales representative.

For information on Freescale's Environmental Products program, go to <http://www.freescale.com/epp>.

Information in this document is provided solely to enable system and software implementers to use Freescale Semiconductor products. There are no express or implied copyright licenses granted hereunder to design or fabricate any integrated circuits or integrated circuits based on the information in this document. Freescale Semiconductor reserves the right to make changes without further notice to any products herein. Freescale Semiconductor makes no warranty, representation or guarantee regarding the suitability of its products for any particular purpose, nor does Freescale Semiconductor assume any liability arising out of the application or use of any product or circuit, and specifically disclaims any and all liability, including without limitation consequential or incidental damages. "Typical" parameters which may be provided in Freescale Semiconductor data sheets and/or specifications can and do vary in different applications and actual performance may vary over time. All operating parameters, including "Typicals" must be validated for each customer application by customer's technical experts. Freescale Semiconductor does not convey any license under its patent rights nor the rights of others. Freescale Semiconductor products are not designed, intended, or authorized for use as components in systems intended for surgical implant into the body, or other applications intended to support or sustain life, or for any other application in which the failure of the Freescale Semiconductor product could create a situation where personal injury or death may occur. Should Buyer purchase or use Freescale Semiconductor products for any such unintended or unauthorized application, Buyer shall indemnify and hold Freescale Semiconductor and its officers, employees, subsidiaries, affiliates, and distributors harmless against all claims, costs, damages, and expenses, and reasonable attorney fees arising out of, directly or indirectly, any claim of personal injury or death associated with such unintended or unauthorized use, even if such claim alleges that Freescale Semiconductor was negligent regarding the design or manufacture of the part.



元器件交易网

www.cecb2b.com

中发网全新升级平台



WWW.ZFA.CN

全球最大的PDF中文下载站



中发网

www.zfa.cn

PDF 资料下载尽在中发网