

MM53200 Encoder/Decoder

The MM53200 Encoder/Decoder is an MOS/LSI Digital Code Transmitter — Receiver system.

Features

- A single chip contains both the Encoder and Decoder.
- Oscillator stability is non-critical, 5% components may be used.
- Cross interference of receivers in close proximity is virtually eliminated by circuitry which requires 4 valid words to be received, each within 64 ms of the other.

Operation

In the transmit mode the twelve inputs are scanned sequentially producing the output pattern shown in Figure

1. This code is generated at the rate of 0.96 ms/bit, or 11.52 ms/word with 11.52 ms reset pulse between words.

In the receiver mode, the incoming signal is compared to the local code in a sequential manner; if there is an error, the system is reset and begins its comparison on the next pulse. If all twelve bits are received correctly, a "valid" signal will be generated. This signal clears a 64 ms counter and clocks a 3 stage counter. The 3 stage counter counts the "valid" pulses and when 4 pulses have been received, the transmit/receive output goes low. After the transmit/receive output is enabled, the next "valid" must be received within 128 ms, giving a one valid in 6 requirement to keep the transmit/receive output low.

Connection diagrams for the device in the Receive and Transmit modes are shown in Figures 2 and 3.

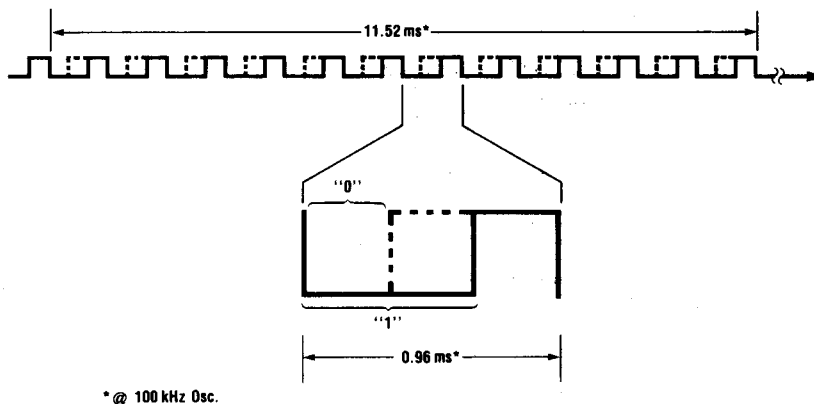
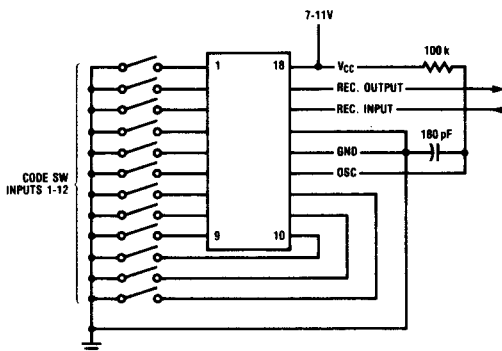
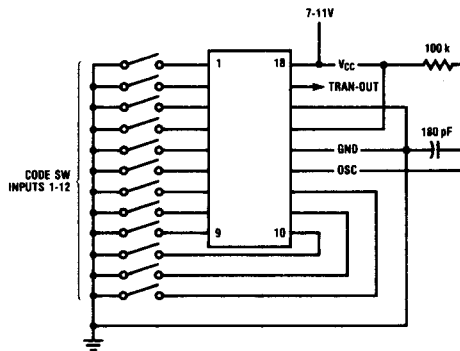

Figure 1. Output Waveform



RECEIVER CODE SW INPUT MUST BE SET TO SAME COMBINATION AS TRANSMITTER

Figure 2. Pin Connections for Receiver Mode



TRANSMITTER CODE SW INPUTS MUST BE SET TO SAME COMBINATION AS RECEIVER

Figure 3. Pin Connections for Transmitter Mode

Design Specifications

Storage Temperature	-65 °C to +125 °C
Operating Temperature	-25 °C to +70 °C
Lead Temperature, Max. (Soldering, 10 seconds)	+300 °C
Power Supply	
V_{DD}	$V_{SS} + 7V$ to $V_{SS} + 11V$
I_{DD}	12 mA Max.

Electrical Characteristics

Parameter	Conditions	Min.	Typ.	Max.	Units
Input Voltage Levels Schmitt Trigger Input	Level 1	$V_{SS} + 4$			V
	Level 0			$V_{SS} + 2$	V
All Other Inputs	Level 1	$V_{DD} - 0.5$		V_{DD}	V
	Level 0	V_{SS}		$V_{SS} + 0.5$	V
Input Resistor to V_{DD}		200k		1.2M	Ω
Output Voltage (trans/rec) Logic High "1"	$I_{SOURCE} 5\mu A$ $I_{SINK} 2mA$	$V_{DD} - 0.5$		V_{DD}	
		V_{SS}		$V_{SS} + 1.0$	
Oscillator Frequency	$\pm 15\%$ exclusive of external components		100		kHz

18-Pin DIP — Top View

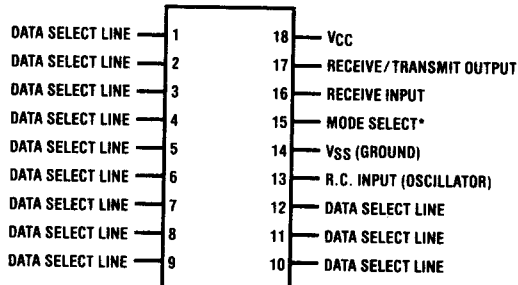

*a. GROUND CONNECTION IS RECEIVER MODE
b. V_{DD} CONNECTION IS TRANSMITTER MODE

Order Number MM53200N
See Package 20

Pin Functions

Pin

- 1-12 These Data Select lines are used to set the address of the encoder/decoder pair. They have on-chip pull-ups and input switches should pull them to ground.
- 13 The R.C. Input is the connection point for the single pin Oscillator. A resistor is hooked from this pin to V_{CC} and a capacitor from this pin to GND. The frequency = $2/RC$. The frequency may be decreased by increasing the resistor value.
- 14 V_{SS} is the Ground Pin.
- 15 The Mode Select pin changes operation of the IC from Receiver to Transmitter. By grounding pin 15 the IC is put in the Receiver mode. By connection to V_{CC} the IC is put in the Transmitter mode.
- 16 The Receiver input receives the digital PCM waveform from the Detector circuit.
- 17 The Output pin produces the PCM waveform when in the Transmit mode and is active low in the Receive mode.
- 18 V_{CC} is the positive supply pin.