



# MX27C1100/27C1024

1M-BIT [128K x 8/64K x 16] CMOS EPROM

## FEATURES

- 64K x 16 organization(MX27C1024, JEDEC pin out)
- 128K x 8 or 64K x 16 organization(MX27C1100, ROM pin out compatible)
- +12.5V programming voltage
- Fast access time: 55/70/85/100/120/150 ns
- Totally static operation
- Completely TTL compatible
- Operating current: 40mA
- Standby current: 100uA
- Package type:
  - 40 pin ceramic DIP
  - 40 pin plastic DIP
  - 40 pin plastic SOP
  - 44 pin PLCC
  - 40pin 10 x 14mm TSOP(I)

## GENERAL DESCRIPTION

The MX27C1024 is a 5V only, 1M-bit, ultraviolet Erasable Programmable Read Only Memory. It is organized as 64K words by 16 bits per word(MX27C1024), 128K x 8 or 64K x 16(MX27C1100), operates from a single + 5 volt supply, has a static standby mode, and features fast single address location programming. All programming signals are TTL levels, requiring a single pulse. For programming outside from the system, existing EPROM programmers

may be used. The MX27C1100/1024 supports a intelligent fast programming algorithm which can result in programming time of less than thirty seconds.

This EPROM is packaged in industry standard 40 pin dual-in-line packages, 40 lead SOP, 44 lead PLCC, and 40 lead TSOP(I) packages.

## PIN CONFIGURATIONS

### CDIP/PDIP/SOP(MX27C1100)

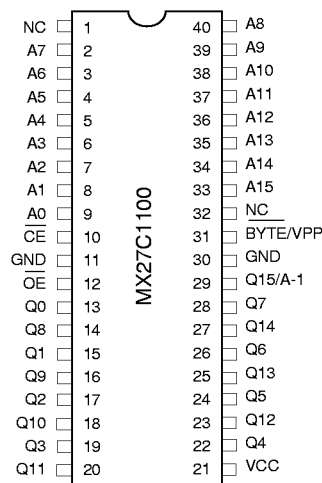

## BLOCK DIAGRAM (MX27C1100)

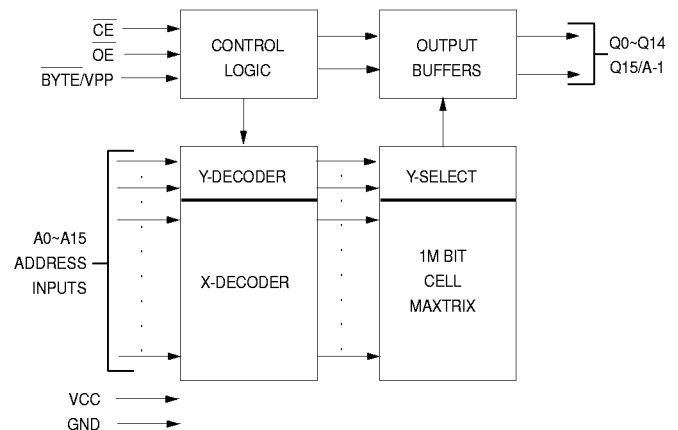

## PIN CONFIGURATIONS

### CDIP/PDIP/SOP(MX27C1024)

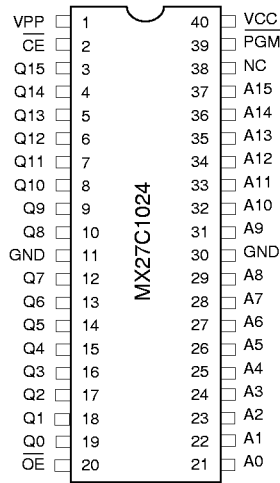

### PLCC(MX27C1024)

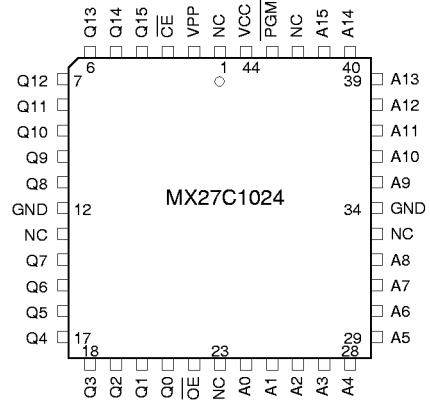

### BLOCK DIAGRAM (MX27C1024)

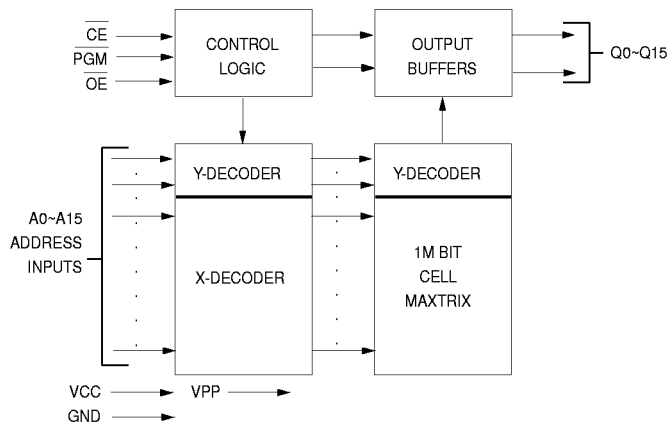

### 10 x 14mm TSOP(I)

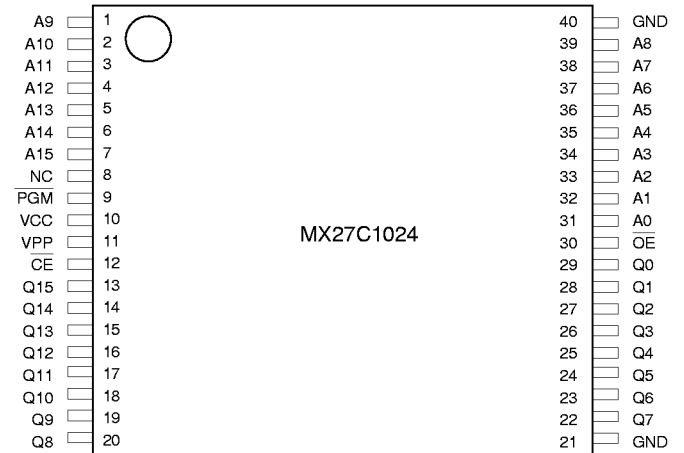



# MX27C1100/27C1024

## PIN DESCRIPTION(MX27C1100)

SYMBOL	PIN NAME
A0~A15	Address Input
Q0~Q14	Data Input/Output
$\overline{CE}$	Chip Enable Input
$\overline{OE}$	Output Enable Input
BYTE/VPP	Word/Byte Selection /Program Supply Voltage
Q15/A-1	Q15(Word mode)/LSB addr. (Byte mode)
VCC	Power Supply Pin (+5V)
GND	Ground Pin

## PIN DESCRIPTION(MX27C1024)

SYMBOL	PIN NAME
A0~A15	Address Input
Q0~Q15	Data Input/Output
$\overline{CE}$	Chip Enable Input
$\overline{OE}$	Output Enable Input
$\overline{PGM}$	Program Enable Input
VPP	Program Supply Voltage
VCC	Power Supply Pin (+5V)
GND	Ground Pin

## TRUTH TABLE OF $\overline{BYTE}$ FUNCTION(MX27C1100)

### BYTE MODE( $\overline{BYTE} = \text{GND}$ )

$\overline{CE}$	$\overline{OE}$	Q15/A-1	MODE	Q0-Q7	SUPPLY CURRENT
H	X	X	Non selected	High Z	Standby(ICC2)
L	H	X	Non selected	High Z	Operating(ICC1)
L	L	A-1 input	Selected	DOUT	Operating(ICC1)

### WORD MODE( $\overline{BYTE} = \text{VCC}$ )

$\overline{CE}$	$\overline{OE}$	Q15/A-1	MODE	Q0-Q14	SUPPLY CURRENT
H	X	High Z	Non selected	High Z	Standby(ICC2)
L	H	High Z	Non selected	High Z	Operating(ICC1)
L	L	DOUT	Selected	DOUT	Operating(ICC1)

NOTE : X = H or L



## FUNCTIONAL DESCRIPTION

### THE ERASURE OF THE MX27C1100/1024

The MX27C1100/1024 is erased by exposing the chip to an ultraviolet light source. A dosage of 15 W seconds/cm<sup>2</sup> is required to completely erase a MX27C1100/1024. This dosage can be obtained by exposure to an ultraviolet lamp --- wavelength of 2537 Angstroms (Å) --- with intensity of 12,000 uW/cm<sup>2</sup> for 15 to 20 minutes. The MX27C1100/1024 should be directly under and about one inch from the source and all filters should be removed from the UV light source prior to erasure.

It is important to note that the MX27C1100/1024, and similar devices, will be cleared for all bits of their programmed states with light sources having wavelengths shorter than 4000 Å. Although erasure times will be much longer than that with UV sources at 2537 Å, nevertheless the exposure to fluorescent light and sunlight will eventually erase the MX27C1100/1024 and exposure to them should be prevented to realize maximum system reliability. If used in such an environment, the package window should be covered by an opaque label or substance.

### THE PROGRAMMING OF THE MX27C1100/1024

When the MX27C1100/1024 is delivered, or it is erased, the chip has all 1M bits in the "ONE" or HIGH state. "ZEROS" are loaded into the MX27C1100/1024 through the procedure of programming.

For programming, the data to be programmed is applied with 16 bits in parallel to the data pins.

VCC must be applied simultaneously or before VPP, and removed simultaneously or after VPP. When programming an MXIC EPROM, a 0.1uF capacitor is required across VPP and ground to suppress spurious voltage transients which may damage the device.

### FAST PROGRAMMING

The device is set up in the fast programming mode when the programming voltage  $V_{PP} = 12.75V$  is applied, with  $V_{CC} = 6.25V$  and  $PGM = VIL$  (or  $OE = VIH$ ) (Algorithm is shown in Figure 1). The programming is achieved by applying a single TTL low level 100us pulse to the PGM input after addresses and data line are stable. If the data

is not verified, an additional pulse is applied for a maximum of 25 pulses. This process is repeated while sequencing through each address of the device. When the programming mode is completed, the data in all address is verified at  $V_{CC} = V_{PP} = 5V \pm 10\%$ .

### PROGRAM INHIBIT MODE

Programming of multiple MX27C1100/1024's in parallel with different data is also easily accomplished by using the Program Inhibit Mode. Except for CE and OE, all like inputs of the parallel MX27C1100/1024 may be common. A TTL low-level program pulse applied to an MX27C1100/1024 CE input with  $V_{PP} = 12.5 \pm 0.5V$  will program the MX27C1100/1024. A high-level CE input inhibits the other MX27C1100/1024s from being programmed.

### PROGRAM VERIFY MODE

Verification should be performed on the programmed bits to determine that they were correctly programmed. The verification should be performed with OE and CE at VIL (for MX27C1024), OE at VIL, CE at VIH (for MX27C1100) and VPP at its programming voltage.

### AUTO IDENTIFY MODE

The auto identify mode allows the reading out of a binary code from an EPROM that will identify its manufacturer and device type. This mode is intended for use by programming equipment for the purpose of automatically matching the device to be programmed with its corresponding programming algorithm. This mode is functional in the  $25^{\circ}C \pm 5^{\circ}C$  ambient temperature range that is required when programming the MX27C1100/1024.

To activate this mode, the programming equipment must force  $12.0 \pm 0.5V$  on address line A9 of the device. Two identifier bytes may then be sequenced from the device outputs by toggling address line A0 from VIL to VIH. All other address lines must be held at VIL during auto identify mode.

Byte 0 (A0 = VIL) represents the manufacturer code, and byte 1 (A0 = VIH), the device identifier code. For the MX27C1100/1024, these two identifier bytes are given in the Mode Select Table. All identifiers for manufacturer and device codes will possess odd parity, with the MSB (Q15) defined as the parity bit.

### READ MODE

The MX27C1100/1024 has two control functions, both of which must be logically satisfied in order to obtain data at the outputs. Chip Enable (CE) is the power control and should be used for device selection. Output Enable (OE) is the output control and should be used to gate data to the output pins, independent of device selection. Assuming that addresses are stable, address access time ( $t_{ACC}$ ) is equal to the delay from CE to output ( $t_{CE}$ ). Data is available at the outputs  $t_{OE}$  after the falling edge of OE's, assuming that CE has been LOW and addresses have been stable for at least  $t_{ACC} - t_{OE}$ .

## WORD-WIDE MODE

With BYTE/VPP at  $V_{CC} \pm 0.2V$  outputs Q0-7 present data Q0-7 and outputs Q8-15 present data Q8-15, after CE and OE are appropriately enabled.

## BYTE-WIDE MODE

With BYTE/VPP at  $GND \pm 0.2V$ , outputs Q8-15 are tri-stated. If  $Q_{15}/A-1 = V_{IH}$ , outputs Q0-7 present data bits Q8-15. If  $Q_{15}/A-1 = V_{IL}$ , outputs Q0-7 present data bits Q0-7.

## STANDBY MODE

The MX27C1100/1024 has a CMOS standby mode which reduces the maximum VCC current to 100  $\mu A$ . It is placed in CMOS standby when CE is at  $V_{CC} \pm 0.3 V$ . The MX27C1100/1024 also has a TTL-standby mode which reduces the maximum VCC current to 1.5 mA. It is placed in TTL-standby when CE is at  $V_{IH}$ . When in standby mode, the outputs are in a high-impedance state, independent of the OE input.

## TWO-LINE OUTPUT CONTROL FUNCTION

To accommodate multiple memory connections, a two-line control function is provided to allow for:

1. Low memory power dissipation,
2. Assurance that output bus contention will not occur.

It is recommended that CE be decoded and used as the

primary device-selecting function, while OE be made a common connection to all devices in the array and connected to the READ line from the system control bus. This assures that all deselected memory devices are in their low-power standby mode and that the output pins are only active when data is desired from a particular memory device.

## SYSTEM CONSIDERATIONS

During the switch between active and standby conditions, transient current peaks are produced on the rising and falling edges of Chip Enable. The magnitude of these transient current peaks is dependent on the output capacitance loading of the device. At a minimum, a 0.1  $\mu F$  ceramic capacitor (high frequency, low inherent inductance) should be used on each device between VCC and GND to minimize transient effects. In addition, to overcome the voltage drop caused by the inductive effects of the printed circuit board traces on EPROM arrays, a 4.7  $\mu F$  bulk electrolytic capacitor should be used between VCC and GND for each eight devices. The location of the capacitor should be close to where the power supply is connected to the array.



# MX27C1100/27C1024

## MODE SELECT TABLE (MX27C1024)

MODE	PINS						
	$\overline{CE}$	$\overline{OE}$	$\overline{PGM}$	A0	A9	VPP	OUTPUTS
Read	VIL	VIL	X	X	X	VCC	DOUT
Output Disable	VIL	VIH	X	X	X	VCC	High Z
Standby (TTL)	VIH	X	X	X	X	VCC	High Z
Standby (CMOS)	VCC±0.3V	X	X	X	X	VCC	High Z
Program	VIL	VIH	VIL	X	X	VPP	DIN
Program Verify	VIL	VIL	VIH	X	X	VPP	DOUT
Program Inhibit	VIH	X	X	X	X	VPP	High Z
Manufacturer Code(3)	VIL	VIL	X	VIL	VH	VCC	00C2H
Device Code(3)	VIL	VIL	X	VIH	VH	VCC	0115H

**NOTES:** 1. VH = 12.0 V ± 0.5 V  
2. X = Either VIH or VIL

3. A1 - A8 = A10 - A15 = VIL(For auto select)  
4. See DC Programming Characteristics for VPP voltage during programming.

## MODE SELECT TABLE (MX27C1100)

MODE	$\overline{CE}$	$\overline{OE}$	A9	A0	BYTE/			
					Q15/A-1	VPP(5)	Q8-14	Q0-7
Read (Word)	VIL	VIL	X	X	Q15 Out	VCC	Q8-14 Out	Q0-7 Out
Read (Upper Byte)	VIL	VIL	X	X	VIH	GND	High Z	Q8-15 Out
Read (Lower Byte)	VIL	VIL	X	X	VIL	GND	High Z	Q0-7 Out
Output Disable	VIL	VIH	X	X	High Z	X	High Z	High Z
Standby	VIH	X	X	X	High Z	X	High Z	High Z
Program	VIL	VIH	X	X	Q15 In	VPP	Q8-14 In	Q0-7 In
Program Verify	VIH	VIL	X	X	Q15 Out	VPP	Q8-14 Out	Q0-7 Out
Program Inhibit	VIH	VIH	X	X	High Z	VPP	High Z	High Z
Manufacturer Code(3)	VIL	VIL	VH	VIL	0B	VCC	00H	C2H
Device Code(3)	VIL	VIL	VH	VIH	0B	VCC	01H	12H

**NOTES:** 1. VH = 12.0V ± 0.5V  
2. X = Either VIH or VIL  
3. A1 - A8, A10 - A15 = VIL(For auto select)

4. See DC Programming Characteristics for VPP voltages.  
5. BYTE/VPP is intended for operation under DC Voltage conditions only.

FIGURE 1. FAST PROGRAMMING FLOW CHART

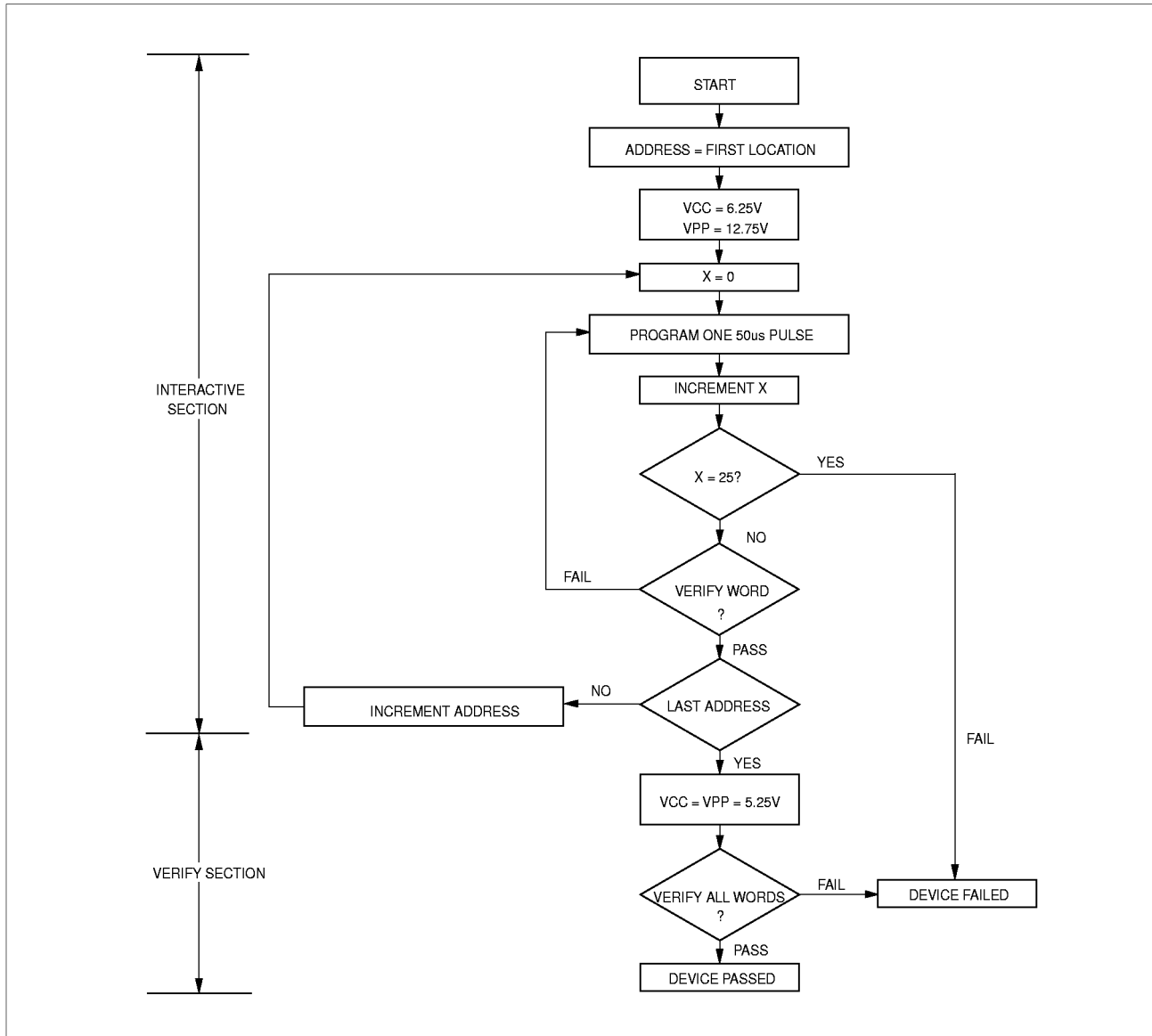

## SWITCHING TEST CIRCUITS

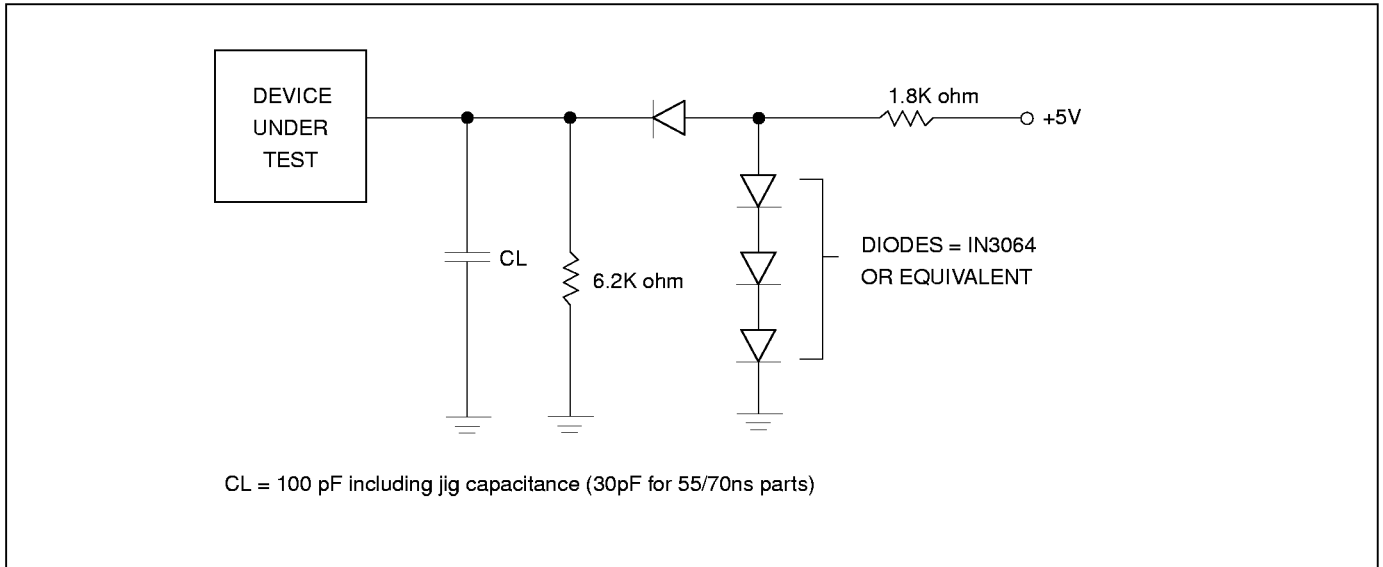

## SWITCHING TEST WAVEFORMS

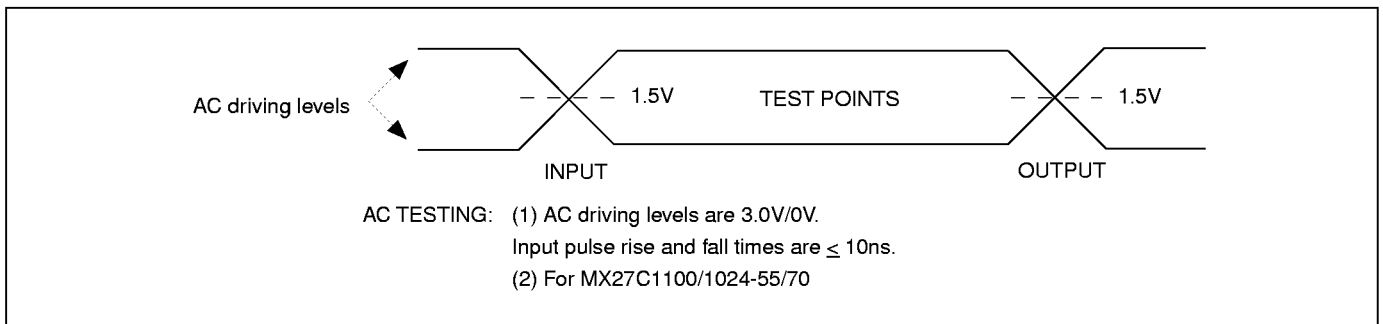
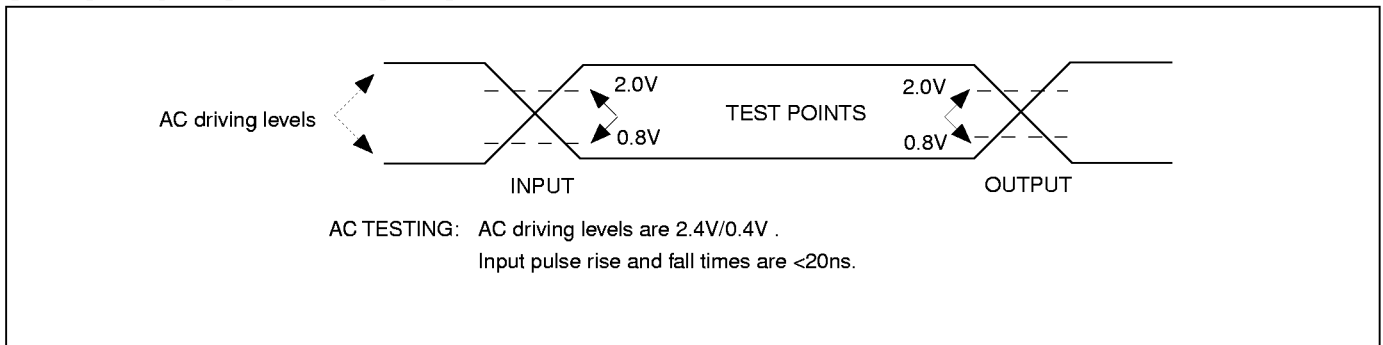



# MX27C1100/27C1024

## ABSOLUTE MAXIMUM RATINGS

RATING	VALUE
Ambient Operating Temperature	-40°C to 85°C
Storage Temperature	-65°C to 125°C
Applied Input Voltage	-0.5V to 7.0V
Applied Output Voltage	-0.5V to VCC + 0.5V
VCC to Ground Potential	-0.5V to 7.0V
A9 & Vpp	-0.5V to 13.5V

### NOTICE:

Stresses greater than those listed under ABSOLUTE MAXIMUM RATINGS may cause permanent damage to the device. This is a stress rating only and functional operation of the device at these or any other conditions above those indicated in the operational sections of this specification is not implied. Exposure to absolute maximum rating conditions for extended period may affect reliability.

### NOTICE:

Specifications contained within the following tables are subject to change.

## DC/AC Operating Conditions for Read Operation

		MX27C1100/1024					
		-55*	-70	-85	-10	-12	-15
Operating Temperature	Commercial	0°C to 55°C	0°C to 70°C	0°C to 70°C	0°C to 70°C	0°C to 70°C	0°C to 70°C
	Industrial **		-40°C to 85°C	-40°C to 85°C	-40°C to 85°C	-40°C to 85°C	-40°C to 85°C
Vcc Power Supply		Vcc ± 5%	Vcc ± 10%	Vcc ± 10%	Vcc ± 10%	Vcc ± 10%	Vcc ± 10%

\* : 55ns for MX27C1024 only

\*\* : Industrial grade for MX27C1024 only

## DC CHARACTERISTICS

SYMBOL	PARAMETER	MIN.	MAX.	UNIT	CONDITIONS
VOH	Output High Voltage	2.4		V	IOH = -0.4mA
VOL	Output Low Voltage		0.4	V	IOL = 2.1mA
VIH	Input High Voltage	2.0	VCC + 0.5	V	
VIL	Input Low Voltage	-0.3	0.8	V	
ILI	Input Leakage Current	-10	10	uA	VIN = 0 to 5.5V
ILO	Output Leakage Current	-10	10	uA	VOUT = 0 to 5.5V
ICC3	VCC Power-Down Current		100	uA	$\overline{CE} = VCC \pm 0.3V$
ICC2	VCC Standby Current		1.5	mA	$\overline{CE} = VIH$
ICC1	VCC Active Current		40	mA	$\overline{CE} = VIL, f=5MHz, I_{out} = 0mA$
IPP	VPP Supply Current Read		10	uA	$\overline{CE} = \overline{OE} = VIL, VPP = 5.5V$

## CAPACITANCE TA = 25°C, f = 1.0 MHz (Sampled only)

SYMBOL	PARAMETER	TYP.	MAX.	UNIT	CONDITIONS
CIN	Input Capacitance	8	12	pF	VIN = 0V
COUT	Output Capacitance	8	12	pF	VOUT = 0V
CVPP	VPP Capacitance	18	25	pF	VPP = 0V



# MX27C1100/27C1024

## AC CHARACTERISTICS

SYMBOL	PARAMETER	27C1024-55		27C1100/1024-70		27C1100/1024-85		UNIT	CONDITIONS
		MIN.	MAX.	MIN.	MAX.	MIN.	MAX.		
tACC	Address to Output Delay		55		70		85	ns	$\overline{CE} = \overline{OE} = \text{VIL}$
tCE	Chip Enable to Output Delay		55		70		85	ns	$\overline{OE} = \text{VIL}$
tOE	Output Enable to Output Delay		30		35		40	ns	$\overline{CE} = \text{VIL}$
tDF	$\overline{OE}$ High to Output Float, or $\overline{CE}$ High to Output Float	0	20	0	20	0	25	ns	
tOH	Output Hold from Address, $\overline{CE}$ or $\overline{OE}$ which ever occurred first	0		0		0		ns	
*tBHA	$\overline{BYTE}$ Access Time				70		85	ns	
*tOHB	$\overline{BYTE}$ Output Hold Time			0		0		ns	
*tBHZ	$\overline{BYTE}$ Output Delay Time				70		70	ns	
*tBLZ	$\overline{BYTE}$ Output Set Time			10		10		ns	

\* : for MX27C1100 only

## AC CHARACTERISTICS

SYMBOL	PARAMETER	27C1100/1024-10		27C1100/1024-12		27C1100/1024-15		UNIT	CONDITIONS
		MIN.	MAX.	MIN.	MAX.	MIN.	MAX.		
tACC	Address to Output Delay		100		120		150	ns	$\overline{CE} = \overline{OE} = \text{VIL}$
tCE	Chip Enable to Output Delay		100		120		150	ns	$\overline{OE} = \text{VIL}$
tOE	Output Enable to Output Delay		45		50		65	ns	$\overline{CE} = \text{VIL}$
tDF	$\overline{OE}$ High to Output Float, or $\overline{CE}$ High to Output Float	0	30	0	35	0	50	ns	
tOH	Output Hold from Address, $\overline{CE}$ or $\overline{OE}$ which ever occurred first	0		0		0		ns	
*tBHA	$\overline{BYTE}$ Access Time		100		120		150	ns	
*tOHB	$\overline{BYTE}$ Output Hold Time	0		0		0		ns	
*tBHZ	$\overline{BYTE}$ Output Delay Time		70		70		70	ns	
*tBLZ	$\overline{BYTE}$ Output Set Time	10		10		10		ns	

\* : for MX27C1100 only



# MX27C1100/27C1024

## DC PROGRAMMING CHARACTERISTICS TA = 25°C ± 5°C

SYMBOL	PARAMETER	MIN.	MAX.	UNIT	CONDITIONS
VOH	Output High Voltage	2.4		V	IOH = -0.40mA
VOL	Output Low Voltage		0.4	V	IOL = 2.1mA
VIH	Input High Voltage	2.0	VCC + 0.5	V	
VIL	Input Low Voltage	-0.3	0.8	V	
ILI	Input Leakage Current	-10	10	uA	VIN = 0 to 5.5V
VH	A9 Auto Select Voltage	11.5	12.5	V	
ICC3	VCC Supply Current (Program & Verify)		50	mA	
IPP2	VPP Supply Current(Program)		30	mA	$\overline{CE} = VIL, \overline{OE} = VIH$
VCC1	Fast Programming Supply Voltage	6.00	6.50	V	
VPP1	Fast Programming Voltage	12.5	13.0	V	

## AC PROGRAMMING CHARACTERISTICS TA = 25°C ± 5°C

SYMBOL	PARAMETER	MIN.	MAX.	UNIT	CONDITIONS
tAS	Address Setup Time	2.0		us	
tOES	$\overline{OE}$ Setup Time	2.0		us	
tDS	Data Setup Time	2.0		us	
tAH	Address Hold Time	0		us	
tDH	Data Hold Time	2.0		us	
tDFP	Output Enable to Output Float Delay	0	130	ns	
tVPS	VPP Setup Time	2.0		us	
tPW	$\overline{PGM}$ Program Pulse Width	95	105	us	
tVCS	VCC Setup Time	2.0		us	
tCES	$\overline{CE}$ Setup Time	2.0		us	
tOE	Data valid from $\overline{OE}$		150	ns	

## WAVEFORMS(MX27C1024) READ CYCLE(WORD MODE)

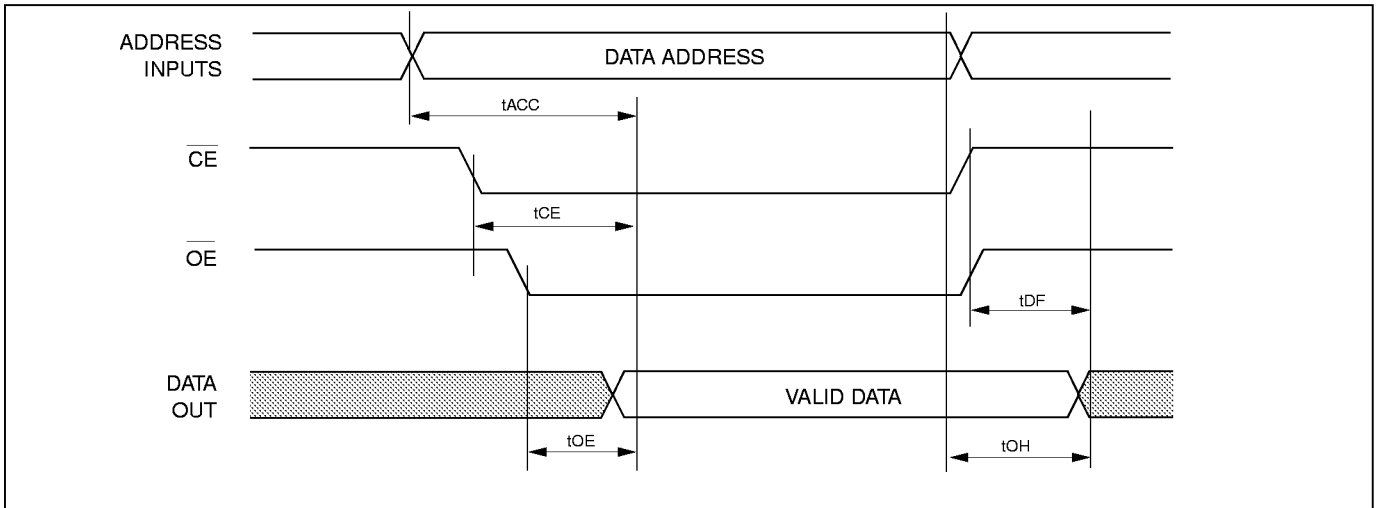

## FAST PROGRAMMING ALGORITHM WAVEFORMS

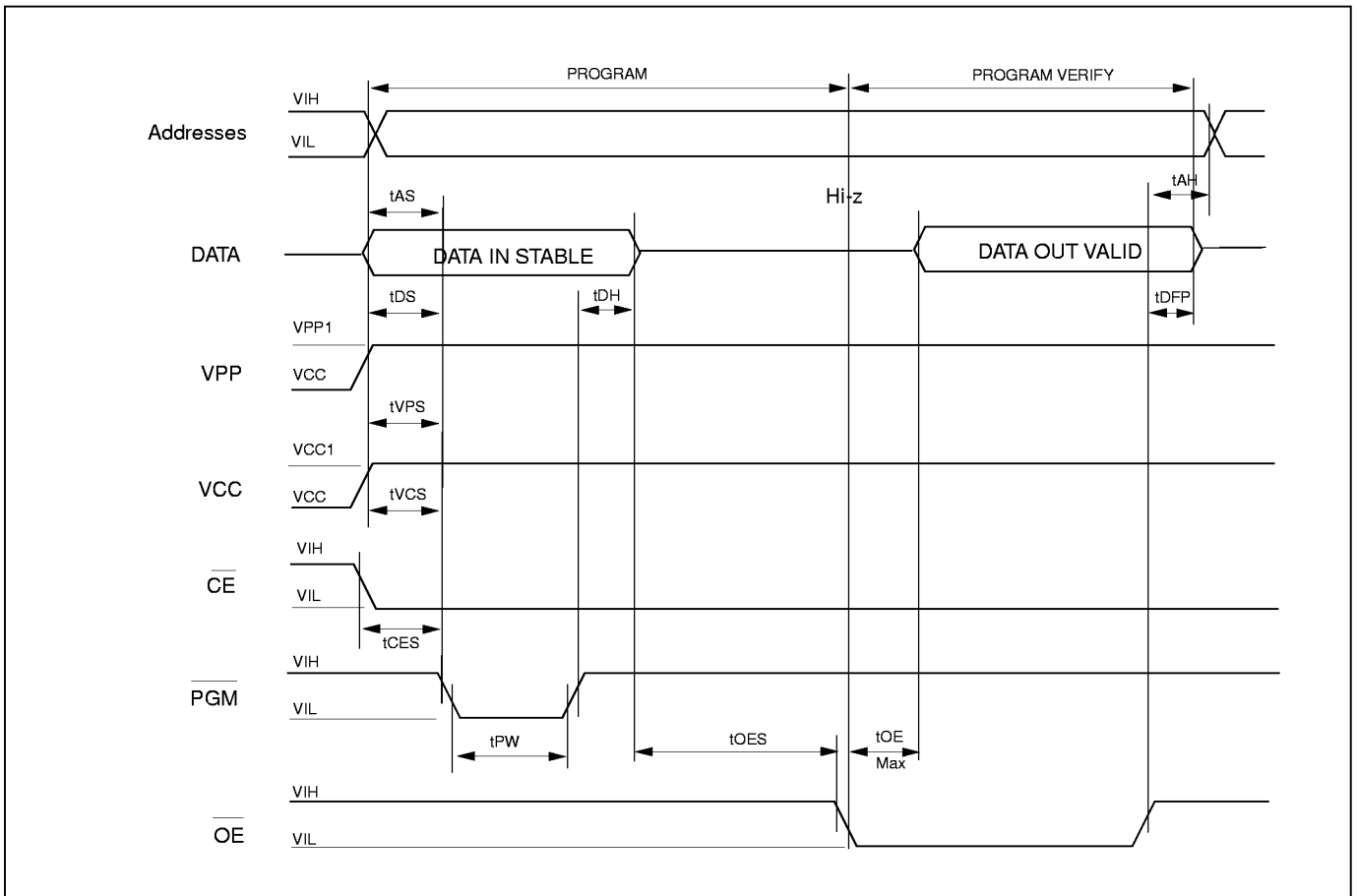

## WAVEFORMS(MX27C1100) READ CYCLE(BYTE MODE)

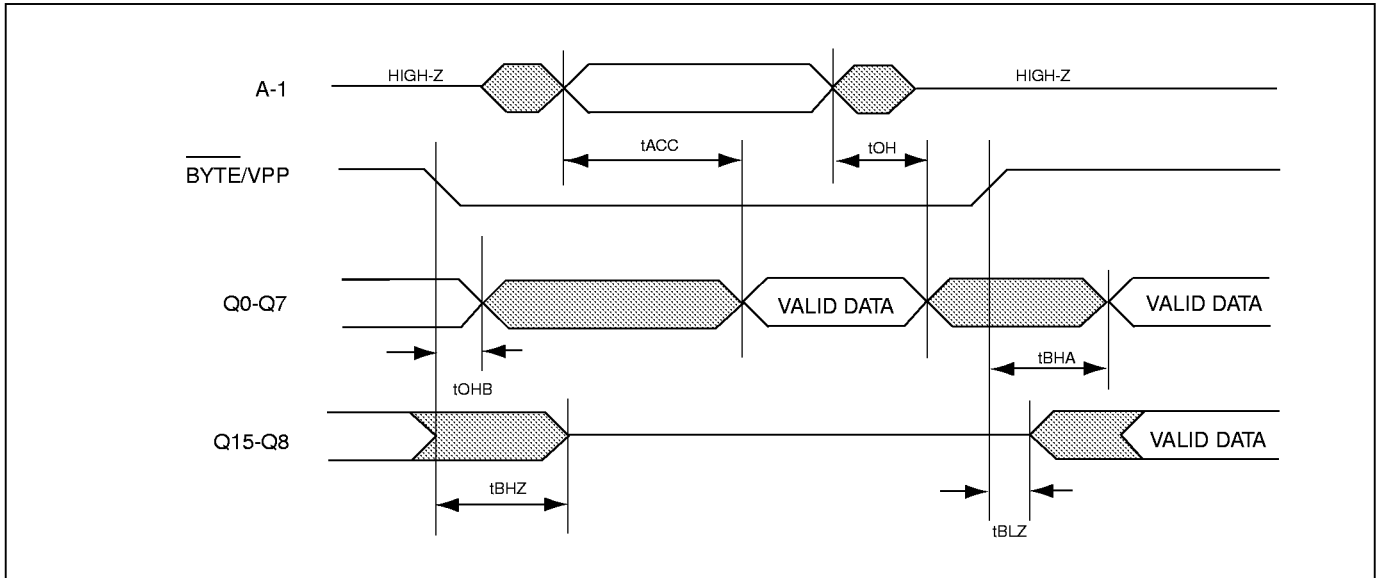

## FAST PROGRAMMING ALGORITHM WAVEFORM

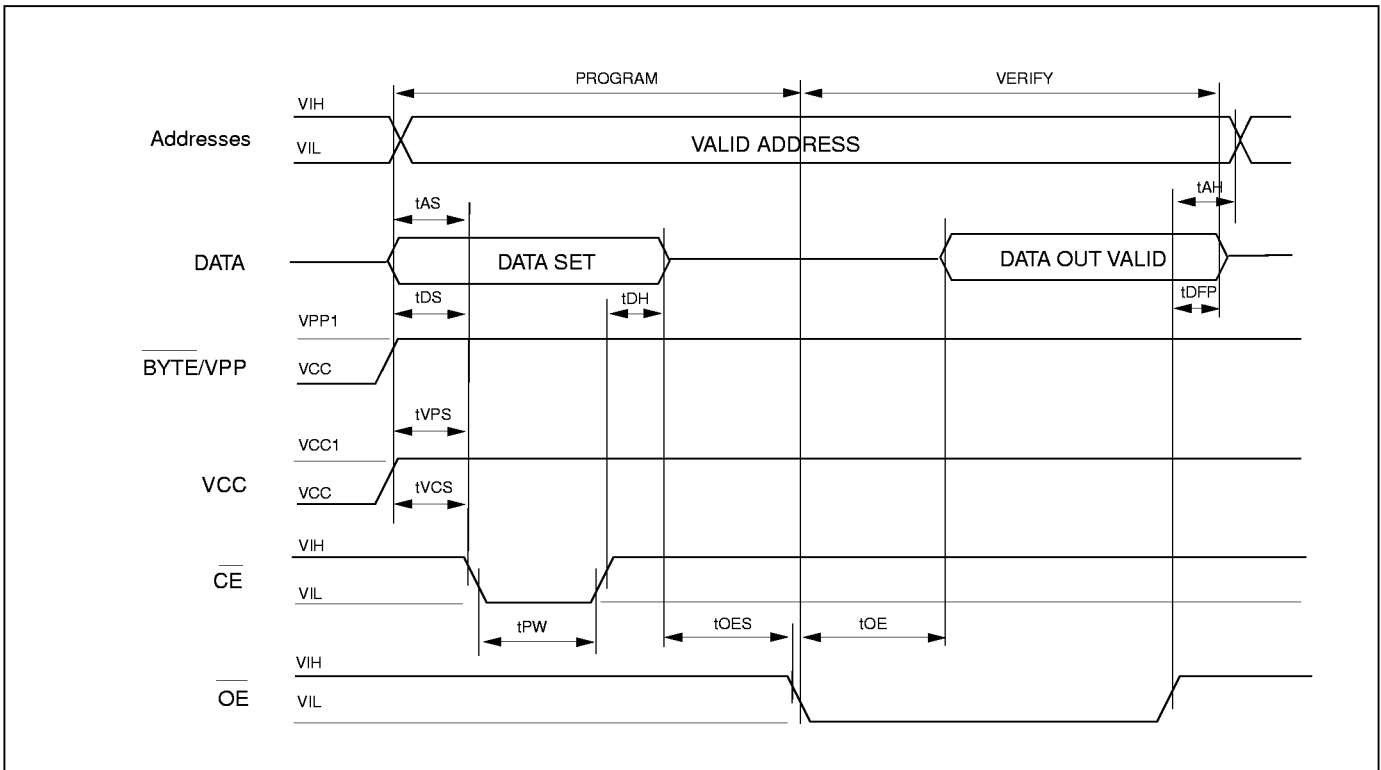



# MX27C1100/27C1024

## ORDER INFORMATION PLASTIC PACKAGE

PART NO.	ACCESS TIME (ns)	OPERATING CURRENT MAX.(mA)	STANDBY CURRENT MAX.(uA)	PACKAGE
MX27C1100PC-70	70	40	100	40 Pin DIP(ROM pin out)
MX27C1100PC-85	85	40	100	40 Pin DIP(ROM pin out)
MX27C1100PC-100	100	40	100	40 Pin DIP(ROM pin out)
MX27C1100PC-120	120	40	100	40 Pin DIP(ROM pin out)
MX27C1100PC-150	150	40	100	40 Pin DIP(ROM pin out)
MX27C1100MC-70	70	40	100	40 Pin SOP
MX27C1100MC-85	85	40	100	40 Pin SOP
MX27C1100MC-100	100	40	100	40 Pin SOP
MX27C1100MC-120	120	40	100	40 Pin SOP
MX27C1100MC-150	150	40	100	40 Pin SOP
MX27C1024PC-55	55	40	100	40 Pin DIP(JEDEC pin out)
MX27C1024PC-70	70	40	100	40 Pin DIP(JEDEC pin out)
MX27C1024PC-85	85	40	100	40 Pin DIP(JEDEC pin out)
MX27C1024PC-100	100	40	100	40 Pin DIP(JEDEC pin out)
MX27C1024PC-120	120	40	100	40 Pin DIP(JEDEC pin out)
MX27C1024PC-150	150	40	100	40 Pin DIP(JEDEC pin out)
MX27C1024QC-55	55	40	100	44 Pin PLCC
MX27C1024QC-70	70	40	100	44 Pin PLCC
MX27C1024QC-85	85	40	100	44 Pin PLCC
MX27C1024QC-100	100	40	100	44 Pin PLCC
MX27C1024QC-120	120	40	100	44 Pin PLCC
MX27C1024QC-150	150	40	100	44 Pin PLCC
MX27C1024MC-55	55	40	100	40 Pin SOP
MX27C1024MC-70	70	40	100	40 Pin SOP
MX27C1024MC-85	85	40	100	40 Pin SOP
MX27C1024MC-100	100	40	100	40 Pin SOP
MX27C1024MC-120	120	40	100	40 Pin SOP
MX27C1024MC-150	150	40	100	40 Pin SOP
MX27C1024TC-55	55	40	100	40 Pin TSOP(I)
MX27C1024TC-70	70	40	100	40 Pin TSOP(I)
MX27C1024TC-85	85	40	100	40 Pin TSOP(I)
MX27C1024TC-100	100	40	100	40 Pin TSOP(I)
MX27C1024TC-120	120	40	100	40 Pin TSOP(I)
MX27C1024TC-150	150	40	100	40 Pin TSOP(I)



# MX27C1100/27C1024

## ORDERING INFORMATION CERAMIC PACKAGE

PART NO.	ACCESS TIME (ns)	OPERATING CURRENT MAX.(mA)	STANDBY CURRENT MAX.(uA)	PACKAGE
MX27C1100DC-70	70	40	100	40 Pin DIP(ROM pin out)
MX27C1100DC-85	85	40	100	40 Pin DIP(ROM pin out)
MX27C1100DC-100	100	40	100	40 Pin DIP(ROM pin out)
MX27C1100DC-120	120	40	100	40 Pin DIP(ROM pin out)
MX27C1100DC-150	150	40	100	40 Pin DIP(ROM pin out)
MX27C1024DC-55	55	40	100	40 Pin DIP(JEDEC pin out)
MX27C1024DC-70	70	40	100	40 Pin DIP(JEDEC pin out)
MX27C1024DC-85	85	40	100	40 Pin DIP(JEDEC pin out)
MX27C1024DC-100	100	40	100	40 Pin DIP(JEDEC pin out)
MX27C1024DC-120	120	40	100	40 Pin DIP(JEDEC pin out)
MX27C1024DC-150	150	40	100	40 Pin DIP(JEDEC pin out)
MX27C1024TI-70	70	40	100	40 Pin TSOP(I)
MX27C1024TI-85	85	40	100	40 Pin TSOP(I)
MX27C1024TI-100	100	40	100	40 Pin TSOP(I)
MX27C1024TI-120	120	40	100	40 Pin TSOP(I)
MX27C1024TI-150	150	40	100	40 Pin TSOP(I)

## PACKAGE INFORMATION

### 40-PIN CERDIP(MSI) WITH WINDOW(600 mil)

ITEM	MILLIMETERS	INCHES
A	53.34 max.	2.100 max.
B	1.85 ± .30	.073 ± .012
C	2.54 [TP]	.100 [TP]
D	.46 ± .05	.018 ± .002
E	48.22	1.900
F	1.40 ± .05	.055 ± .005
G	3.43 ± .38	.135 ± .015
H	.94 ± .41	.037 ± .016
I	5.00	.197
J	15.494 ± 1.27	.610 ± .005
K	14.6558 ± .254	.577 ± .001
L	.25 ± .13	.010 ± .005
M	0~15°	0~15°
N	10.668	.420
O	8.128	.320

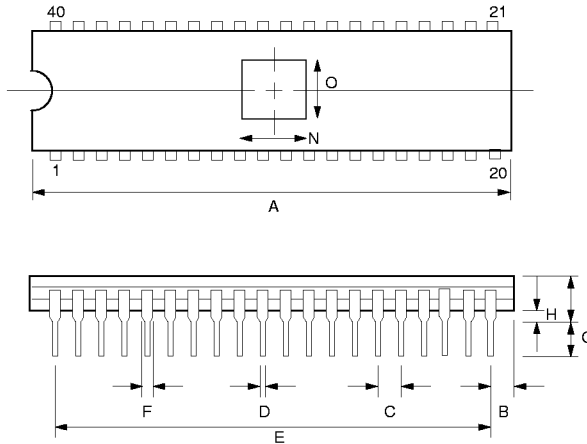

**NOTE:** Each lead centerline is located within .25 mm [.01 inch] of its true position [TP] at maximum material condition.

### 40-PIN PLASTIC DIP(600 mil)

ITEM	MILLIMETERS	INCHES
A	52.54 max.	2.070 max.
B	2.03 [REF]	.080 [REF]
C	2.54 [TP]	.100 [TP]
D	.46 [Typ.]	.018 [Typ.]
E	48.22	1.900
F	1.52 [Typ.]	.060 [Typ.]
G	3.30 ± .25	.130 ± .010
H	.51 [REF]	.020 [REF]
I	3.94 ± .25	.155 ± .010
J	5.33 max.	.210 max.
K	15.22 ± .25	.600 ± .010
L	13.97 ± .25	.550 ± .010
M	.25 [Typ.]	.010 [Typ.]

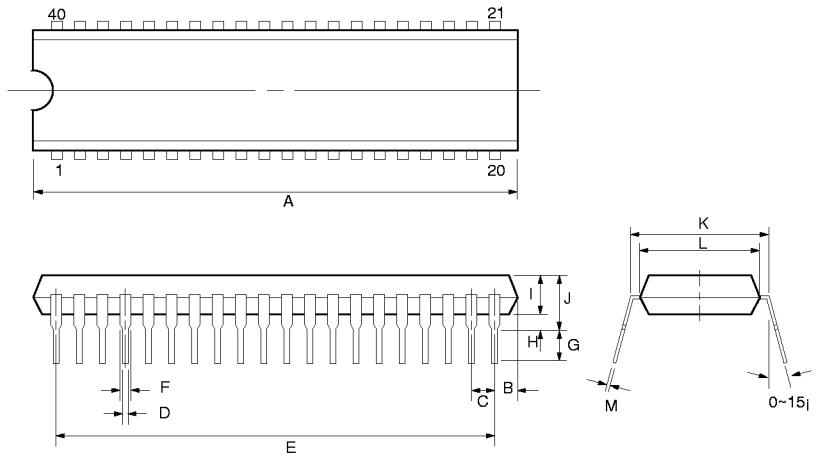

**NOTE:** Each lead centerline is located within .25 mm [.01 inch] of its true position [TP] at maximum material condition.

## PACKAGE INFORMATION

### 44-PIN PLASTIC LEADED CHIP CARRIER (PLCC)

ITEM	MILLIMETERS	INCHES
A	17.53 ± .12	.690 ± .005
B	16.59 ± .12	.653 ± .005
C	16.59 ± .12	.653 ± .005
D	17.53 ± .12	.690 ± .005
E	1.95	.077
F	4.70 max.	.185 max
G	2.55 ± .25	.100 ± .010
H	.51 min.	.020 min.
I	1.27 [Typ.]	.050 [Typ.]
J	.71 ± .10	.028 ± .004
K	.46 ± .10	.018 ± .004
L	15.50 ± .51	.610 ± .020
M	.63 R	.025 R
N	.25 [Typ.]	.010 [Typ.]

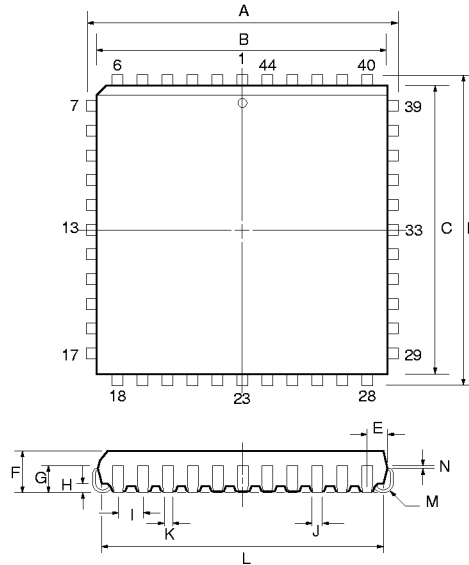

### 40-PIN PLASTIC TSOP

ITEM	MILLIMETERS	INCHES
A	14.0 ± .20	0.551 ± .008
B	12.4 ± .10	0.488 ± .004
C	10.1 max.	0.398 max.
D	0.125 [Typ.]	0.005 [Typ.]
E	.80 [Typ.]	.031 [Typ.]
F	.20 ± .10	.008 ± .004
G	.30 ± .10	.012 ± .004
H	.50 [Typ.]	.020 [Typ.]
I	.45 max.	0.18 max.
J	0 ~ .20	0 ~ .008
K	1.00 ± .10	.039 ± .004
L	1.2 max.	0.047 max.
M	.50	.020
N	0 ~ 10°	0 ~ 10°

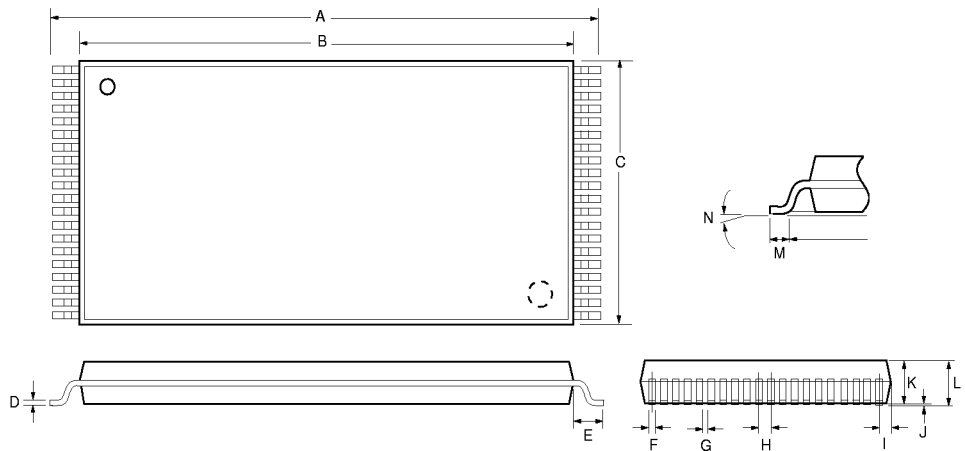

**NOTE:** Each lead centerline is located within .25 mm [.01 inch] of its true position [TP] at maximum material condition.

## 40-PIN PLASTIC SOP(450 mil)

ITEM	MILLIMETERS	INCHES						
A	26.06±.13	1.026±.005						
B	1.00 [REF]	.038 [REF]						
C	1.27 [TP]	.050 [TP]						
D	.41 [Typ.]	.016 [Typ.]						
E	.102 min.	.004 min.						
F	3.0 max.	.118 max.						
G	2.695±.13	.106 ±.005						
H	14.125±.26	.556±.010						
I	11.303±.13	.445±.005	J	.203 [Typ.]	.008 [Typ.]	K	.785±.21	.031±.008
J	.203 [Typ.]	.008 [Typ.]						
K	.785±.21	.031±.008						

**NOTE:** Each lead centerline is located within .25 mm[.01 inch] of its true position [TP] at maximum material condition.

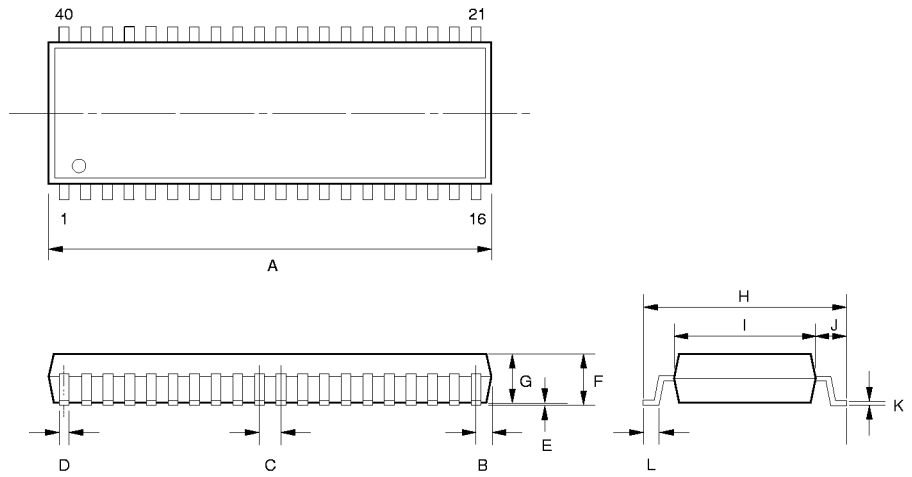



## Revision History

Revision No.	Description	Page	Date
3.0	Revise speed grade from 70/90/120/150ns to 55/70/85/100/120/150ns. Add 40 pin SOP package type.		10/15/1996
4.0	1) Eliminate Interactive Programming Mode. 2) 40-CDIP package quartz lens, change to square shape.		06/14/1997
4.1	IPP : 100uA ----> 10uA		08/08/1997
4.2	Add industrial grade 70/85/100/120/150ns 40-TSOP(I)	P15	11/19/1998