



NE556 SA556 - SE556

GENERAL PURPOSE DUAL BIPOLAR TIMERS

- LOW TURN OFF TIME
- MAXIMUM OPERATING FREQUENCY GREATER THAN 500kHz
- TIMING FROM MICROSECONDS TO HOURS
- OPERATES IN BOTH ASTABLE AND MONOSTABLE MODES
- HIGH OUTPUT CURRENT CAN SOURCE OR SINK 200mA
- ADJUSTABLE DUTY CYCLE
- TTL COMPATIBLE
- TEMPERATURE STABILITY OF 0.005% PER°C

DESCRIPTION

The NE556 dual monolithic timing circuit is a highly stable controller capable of producing accurate time delays or oscillation. In the time delay mode of operation, the time is precisely controlled by one external resistor and capacitor. For a stable operation as an oscillator, the free running frequency and the duty cycle are both accurately controlled with two external resistors and one capacitor.

The circuit may be triggered and reset on falling waveforms, and the output structure can source or sink up to 200mA.

ORDER CODE

Part Number	Temperature Range	Package	
		N	D
NE556	0°C, 70°C	•	•
SA556	-40°C, 105°C	•	•
SE556	-55°C, 125°C	•	•

N = Dual in Line Package (DIP)
D = Small Outline Package (SO) - also available in Tape & Reel (DT)

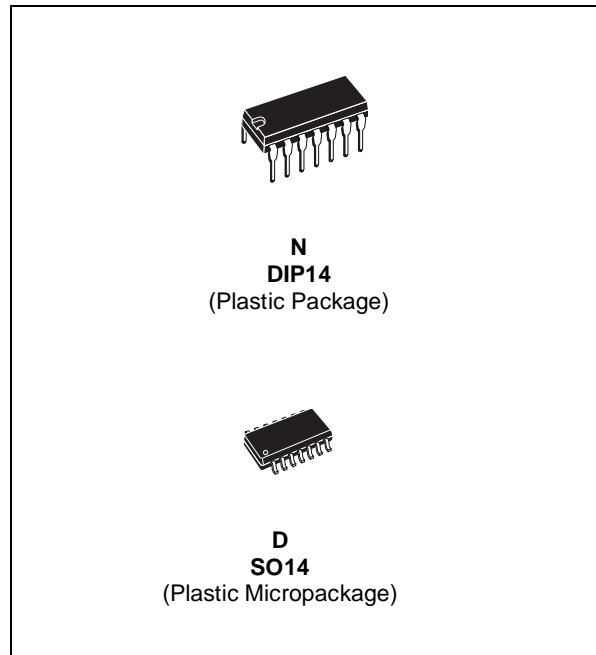

PIN CONNECTIONS (top view)

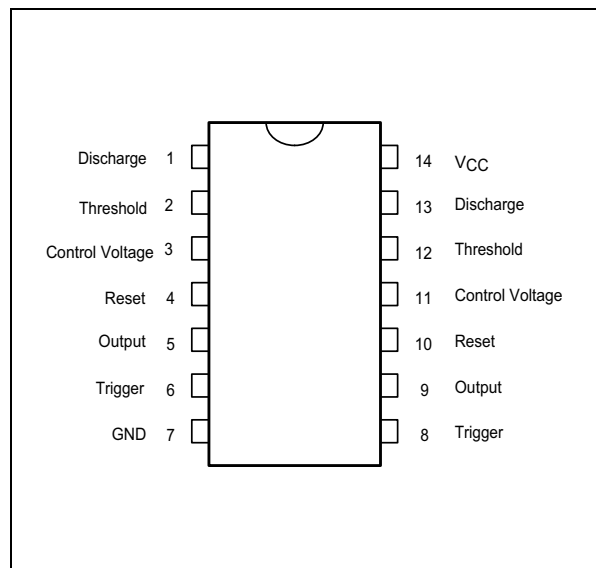

NE556- SA556-SE556

BLOCK DIAGRAM

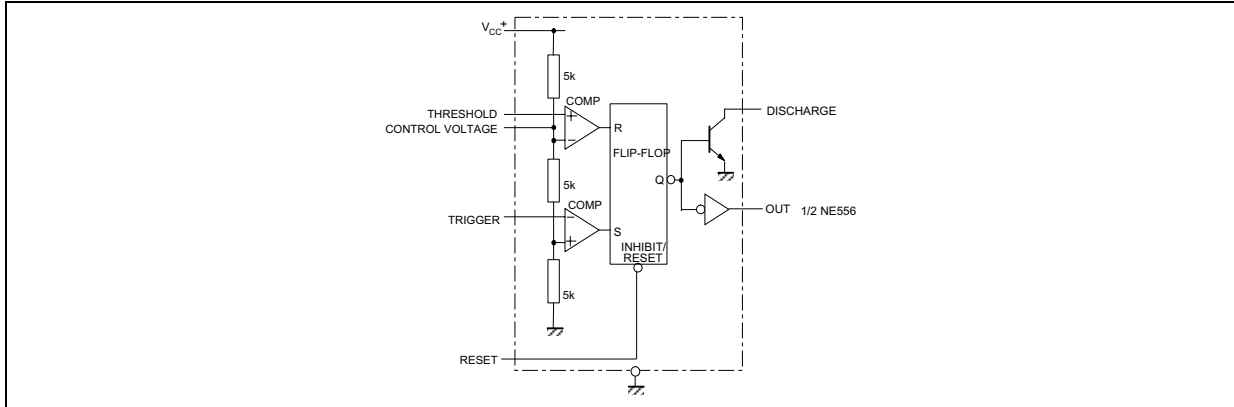

SCHEMATIC DIAGRAM

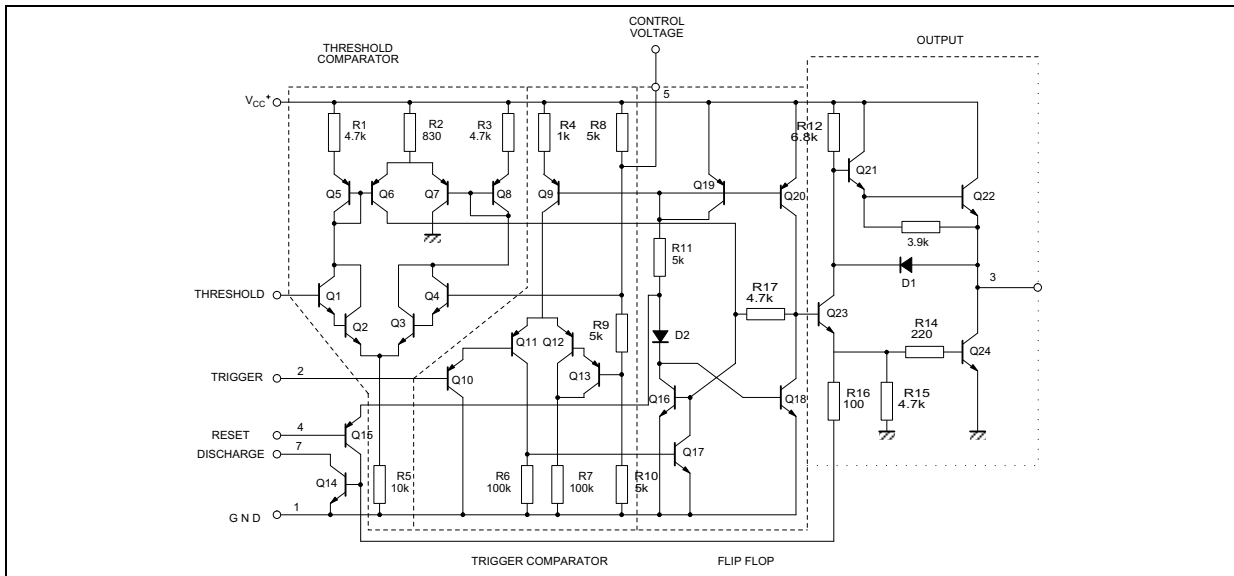

ABSOLUTE MAXIMUM RATINGS

Symbol	Parameter	Value	Unit
V_{CC}	Supply Voltage	18	V
T_j	Junction Temperature	150	°C
T_{stg}	Storage Temperature Range	-65 to 150	°C

OPERATING CONDITIONS

Symbol	Parameter	Value	Unit	
V_{CC}	Supply Voltage	NE556 SA556 SE556	4.5 to 16 4.5 to 16 4.5 to 18	V
$V_{th}, V_{trig}, V_{cl}, V_{reset}$	Maximum Input Voltage	V_{CC}	V	
T_{oper}	Operating Free Air Temperature Range	for NE556 for SA556 for SE556	0 to 70 -40 to 105 -55 to 125	°C

ELECTRICAL CHARACTERISTICS $T_{amb} = +25^{\circ}\text{C}$, $V_{CC} = +5\text{V}$ to $+15\text{V}$ (unless otherwise specified)

Symbol	Parameter	SE556			NE556 - SA556			Unit
		Min.	Typ.	Max.	Min.	Typ.	Max.	
I_{CC}	Supply Current ($R_L = \infty$) - note ¹⁾ (2 timers) Low Stage $V_{CC} = +5\text{V}$		6	10		6	12	mA
	High State $V_{CC} = +15\text{V}$		20	24		20	30	
	Timing Error (monostable) ($R_A = 2\text{k}$ to $100\text{k}\Omega$, $C = 0.1\mu\text{F}$) Initial Accuracy - note ²⁾ Drift with Temperature Drift with Supply Voltage		0.5 30 0.05	2 100 0.2		1 50 0.1	3 30 0.5	% ppm/ $^{\circ}\text{C}$ %/V
	Timing Error (astable) ($R_A, R_B = 1\text{k}\Omega$ to $100\text{k}\Omega$, $C = 0.1\mu\text{F}$, $V_{CC} = +15\text{V}$) Initial Accuracy - see note 2 Drift with Temperature Drift with Supply Voltage		1.5 90 0.15			2.25 150 0.3		% ppm/ $^{\circ}\text{C}$ %/V
V_{CL}	Control Voltage Level $V_{CC} = +15\text{V}$	9.6	10	10.4	9	10	11	V
	$V_{CC} = +5\text{V}$	2.9	3.33	3.8	2.6	3.33	4	
V_{th}	Threshold Voltage $V_{CC} = +15\text{V}$	9.4	10	10.6	8.8	10	11.2	V
	$V_{CC} = +5\text{V}$	2.7	3.33	4	2.4	3.33	4.2	
I_{th}	Threshold Current - note ³⁾		0.1	0.25		0.1	0.25	μA
V_{trig}	Trigger Voltage $V_{CC} = +15\text{V}$	4.8	5	5.2	4.5	5	5.6	V
	$V_{CC} = +5\text{V}$	1.45	1.67	1.9	1.1	1.67	2.2	
I_{trig}	Trigger Current ($V_{trig} = 0\text{V}$)		0.5	0.9		0.5	2.0	μA
V_{reset}	Reset Voltage ⁴⁾	0.4	0.7	1	0.4	0.7	1	V
I_{reset}	Reset Current $V_{reset} = +0.4\text{V}$		0.1	0.4		0.1	0.4	mA
	$V_{reset} = 0\text{V}$		0.4	1		0.4	1.5	
V_{OL}	Low Level Output Voltage $V_{CC} = +15\text{V}$							V
	$I_{O(sink)} = 10\text{mA}$		0.1	0.15		0.1	0.25	
	$I_{O(sink)} = 50\text{mA}$		0.4	0.5		0.4	0.75	
	$I_{O(sink)} = 100\text{mA}$		2	2.2		2	2.5	
	$I_{O(sink)} = 200\text{mA}$		2.5			2.5		
	$V_{CC} = +5\text{V}$		0.1	0.25		0.3	0.4	
V_{OH}	High Level Output Voltage $V_{CC} = +15\text{V}$							V
	$I_{O(sink)} = 200\text{mA}$		13	12.5		12.5		
	$I_{O(sink)} = 100\text{mA}$		13.3	13.3		13.3		
$I_{dis(off)}$	Discharge Pin Leakage Current (output high) ($V_{dis} = 10\text{V}$)		20	100		20	100	nA
	Discharge pin Saturation Voltage (output low) - note ⁵⁾ $V_{CC} = +15\text{V}$, $I_{dis} = 15\text{mA}$		180	480		180	480	mV
$V_{dis(sat)}$	$V_{CC} = +5\text{V}$, $I_{dis} = 4.5\text{mA}$		80	200		80	200	
t_r	Output rise Time		100	200		100	300	ns
t_f	Output Fall Time		100	200		100	300	
t_{off}	Turn off Time - note ⁶⁾ ($V_{reset} = V_{CC}$)		0.5			0.5		μs

1. Supply current when output is high is typically 1mA less.

2. Tested at $V_{CC} = +5\text{V}$ and $V_{CC} = +15\text{V}$

3. This will determine the maximum value of $R_A + R_B$ for +15V operation the max total is $R = 20\text{M}\Omega$ and for 5V operation the max total $R = 3.5\text{M}\Omega$

4. Specified with trigger input high

5. No protection against excessive pin 7 current is necessary, providing the package dissipation rating will not be exceeded

6. Time measured from a positive going input pulse from 0 to $0.8 \times V_{CC}$ into the threshold to the drop from high to low of the output trigger is tied to threshold.

Figure 1 : Minimum Pulse Width Required for Triggering

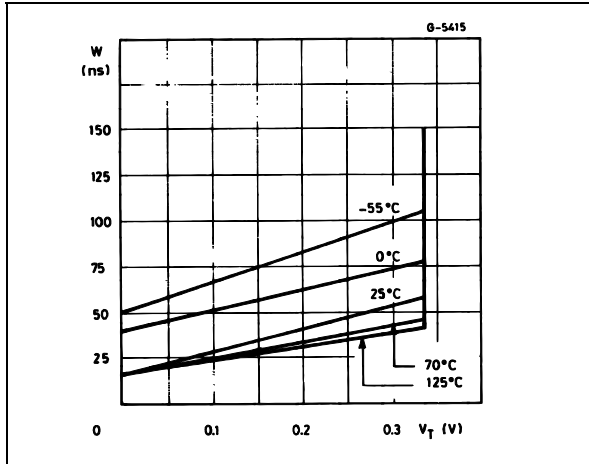

Figure 2 : Supply Current versus Supply Voltage

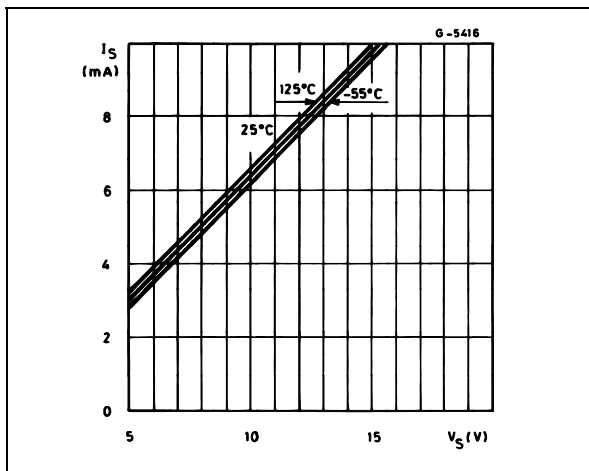

Figure 3 : Delay Time versus Temperature

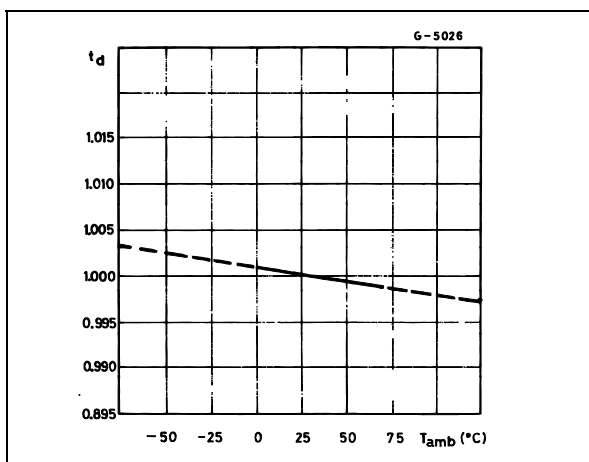

Figure 4 : Low Output Voltage versus Output Sink Current

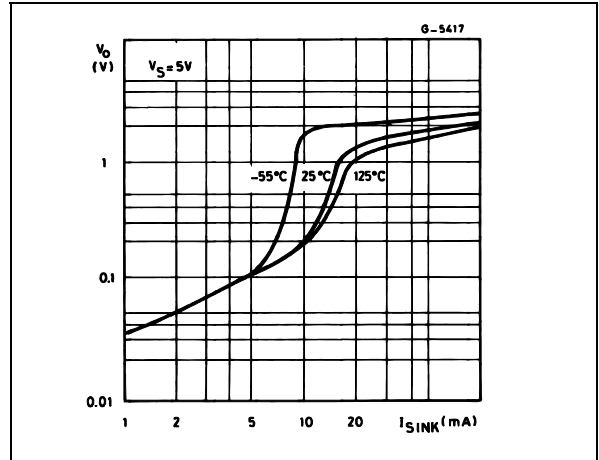

Figure 5 : Low Output Voltage versus Output Sink Current

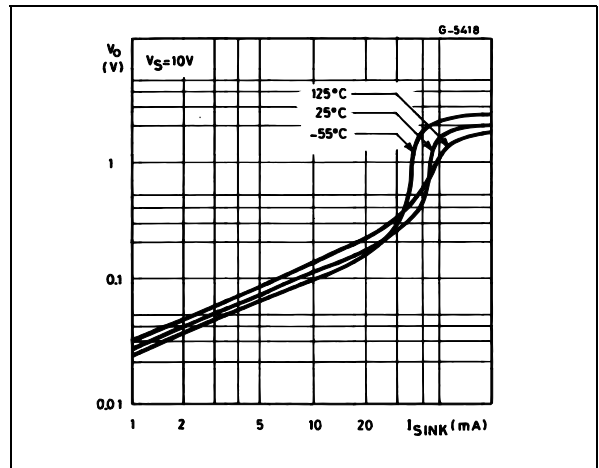

Figure 6 : Low Output Voltage versus Output Sink Current

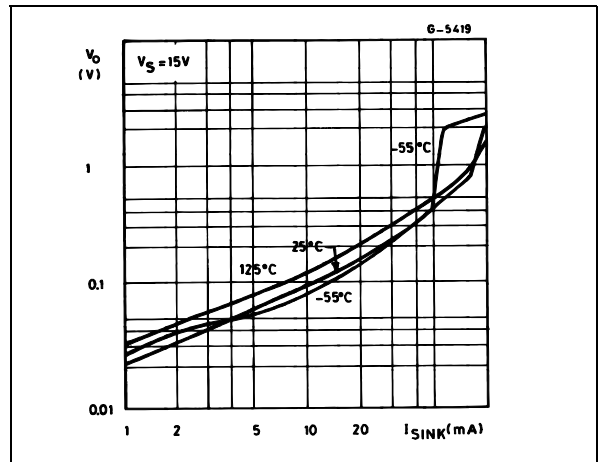

Figure 7 : High Output Voltage Drop versus Output

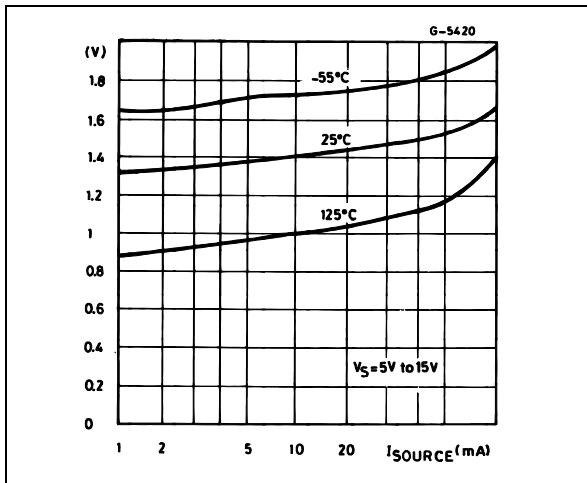

Figure 8 : Delay Time versus Supply Voltage

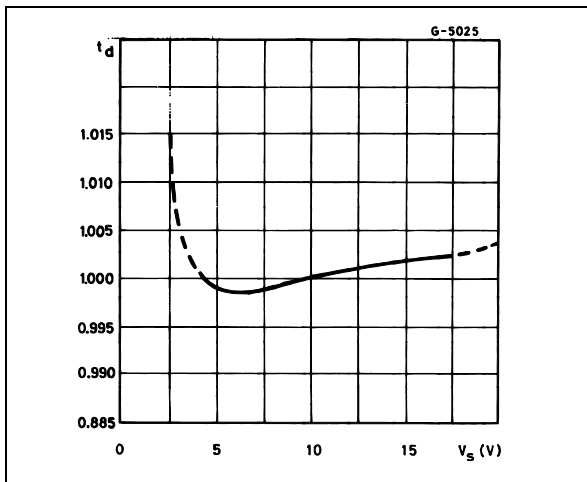
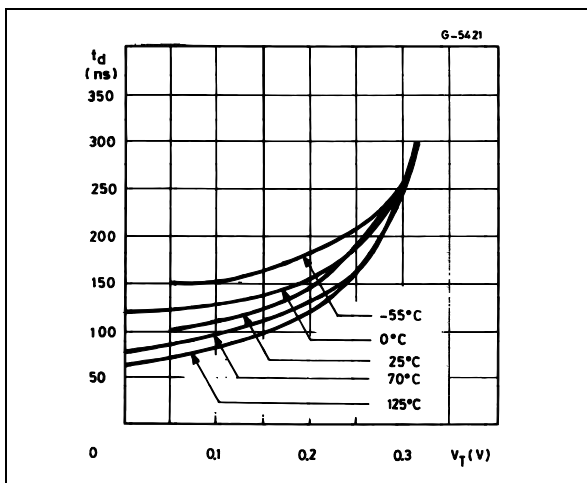
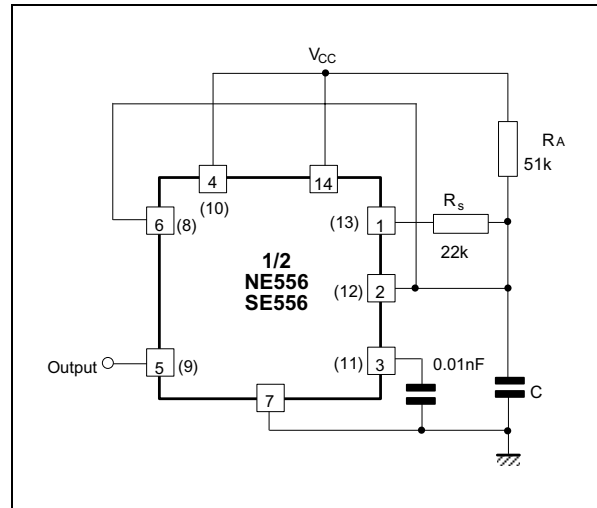

Figure 9 : Propagation Delay versus Voltage Level of Trigger Value



TYPICAL APPLICATION

50% DUTY CYCLE OSCILLATOR



$$t_1 = 0.693 R_A \cdot C$$

$$t_2 = [(R_A R_B)/(R_A + R_B)] C \ln \left[\frac{R_B - 2R_A}{2R_B - R_A} \right]$$

$$f = \frac{t_1}{t_1 + t_2} \quad R_B < \frac{1}{2} R_A t_i$$

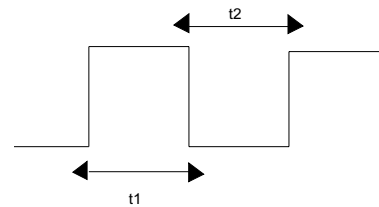

PULSE WIDTH MODULATOR

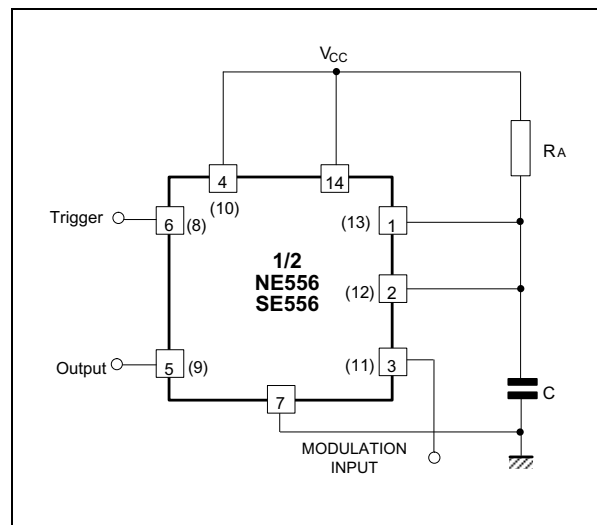

TONE BURST GENERATOR

For a tone burst generator the first timer is used as a monostable and determines the tone duration when triggered by a positive pulse at pin 6. The second timer is enabled by the high output of the monostable. It is connected as an astable and determines the frequency of the tone.

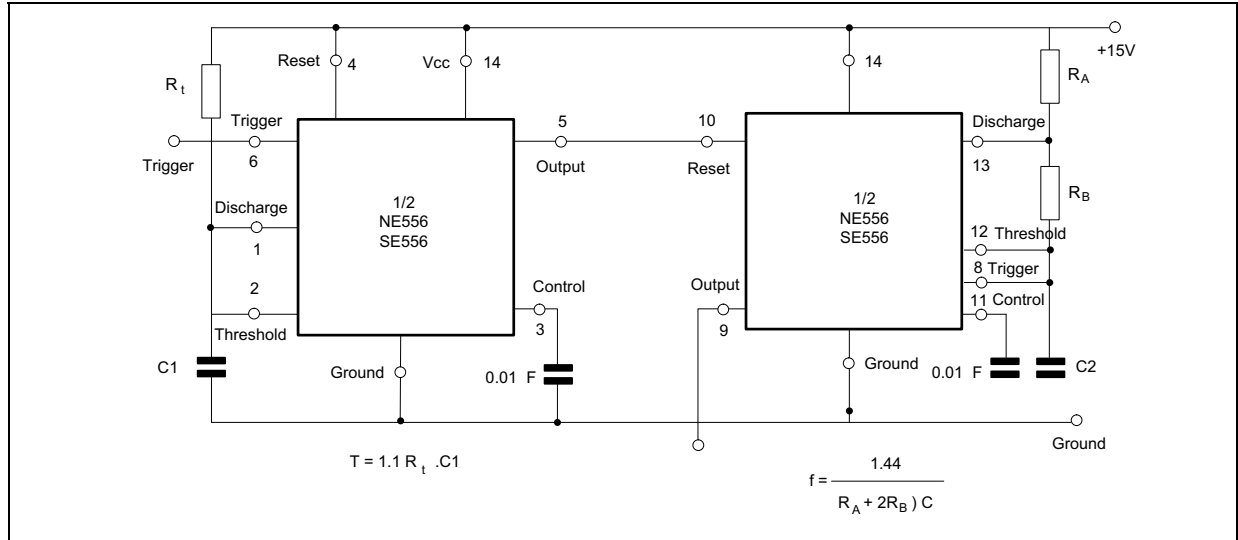

MONOSTABLE OPERATION

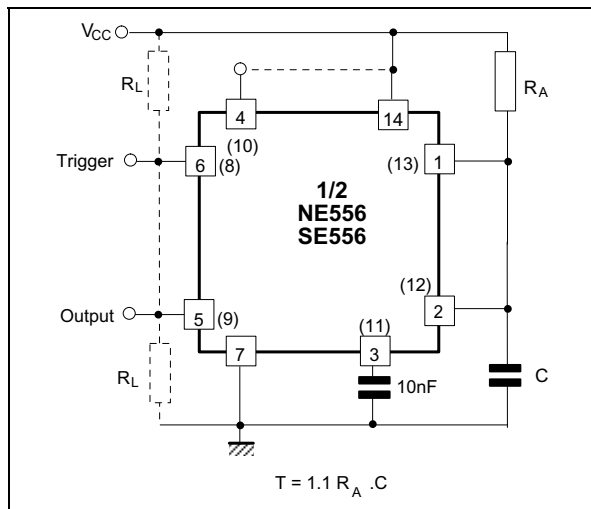

ASTABLE OPERATION

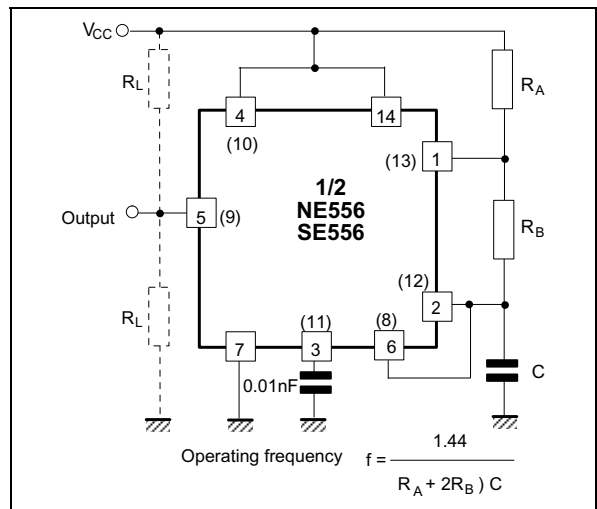

$t_1 = 0.693 (R_A + R_B) C$ Output High
 $t_2 = 0.693 R_B C$ Output Low

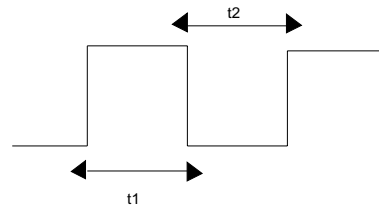

PACKAGE MECHANICAL DATA

Plastic DIP-14 MECHANICAL DATA

DIM.	mm.			inch		
	MIN.	TYP.	MAX.	MIN.	TYP.	MAX.
a1	0.51			0.020		
B	1.39		1.65	0.055		0.065
b		0.5			0.020	
b1		0.25			0.010	
D			20			0.787
E		8.5			0.335	
e		2.54			0.100	
e3		15.24			0.600	
F			7.1			0.280
l			5.1			0.201
L		3.3			0.130	
Z	1.27		2.54	0.050		0.100

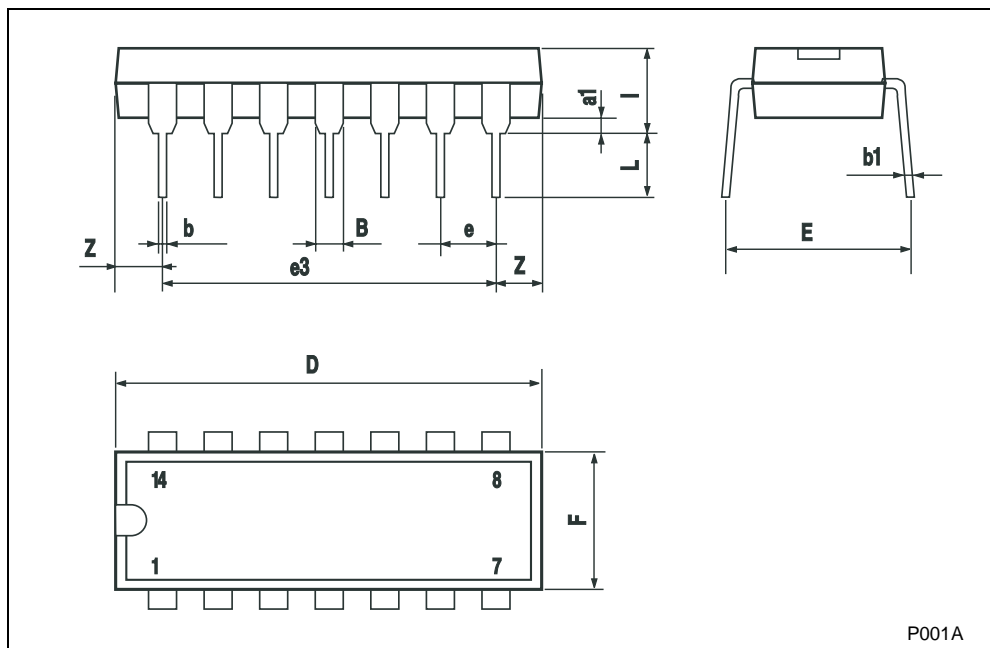

PACKAGE MECHANICAL DATA

SO-14 MECHANICAL DATA						
DIM.	mm.			inch		
	MIN.	TYP.	MAX.	MIN.	TYP.	MAX.
A			1.75			0.068
a1	0.1		0.2	0.003		0.007
a2			1.65			0.064
b	0.35		0.46	0.013		0.018
b1	0.19		0.25	0.007		0.010
C		0.5			0.019	
c1	45° (typ.)					
D	8.55		8.75	0.336		0.344
E	5.8		6.2	0.228		0.244
e		1.27			0.050	
e3		7.62			0.300	
F	3.8		4.0	0.149		0.157
G	4.6		5.3	0.181		0.208
L	0.5		1.27	0.019		0.050
M			0.68			0.026
S	8° (max.)					

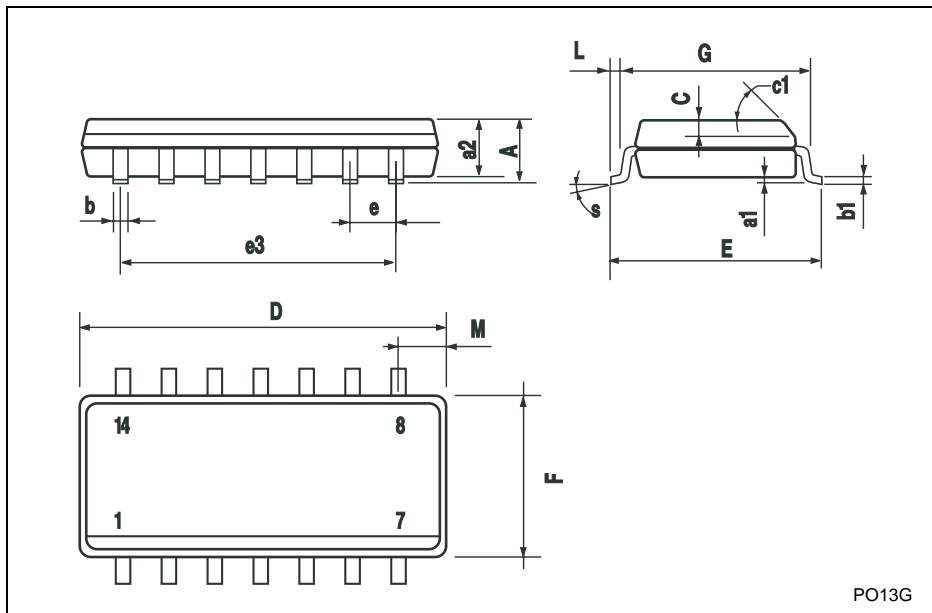

PO13G

Information furnished is believed to be accurate and reliable. However, STMicroelectronics assumes no responsibility for the consequences of use of such information nor for any infringement of patents or other rights of third parties which may result from its use. No license is granted by implication or otherwise under any patent or patent rights of STMicroelectronics. Specifications mentioned in this publication are subject to change without notice. This publication supersedes and replaces all information previously supplied. STMicroelectronics products are not authorized for use as critical components in life support devices or systems without express written approval of STMicroelectronics.

The ST logo is a registered trademark of STMicroelectronics

© 2003 STMicroelectronics - All Rights Reserved
 STMicroelectronics GROUP OF COMPANIES

Australia - Brazil - China - Finland - France - Germany - Hong Kong - India - Italy - Japan - Malaysia - Malta - Morocco
 Singapore - Spain - Sweden - Switzerland - United Kingdom
<http://www.st.com>

