

NMC27C1024
1,048,576-Bit (64k x 16) UV Erasable CMOS PROM
General Description

The NMC27C1024 is a high-speed 1024k UV erasable and electrically reprogrammable CMOS EPROM, ideally suited for applications where fast turnaround, pattern experimentation and low power consumption are important requirements.

The NMC27C1024 is designed to operate with a single +5V power supply with $\pm 5\%$ or $\pm 10\%$ tolerance. The CMOS design allows the part to operate over extended and military temperature ranges.

The NMC27C1024 is packaged in a 40-pin dual in-line package with transparent lid. The transparent lid allows the user to expose the chip to ultraviolet light to erase the bit pattern. A new pattern can then be written electrically into the device by following the programming procedure.

This EPROM is fabricated with National's proprietary, time proven CMOS double-poly silicon gate technology which combines high performance and high density with low power consumption and excellent reliability.

Features

- Clocked sense amps for fast access time down to 120 ns
- Low CMOS power consumption
 - Active Power: 110 mW max
 - Standby Power: 550 μ W max
- Performance compatible to 16-bit and 32-bit microprocessors
- Extended temperature range (NMC27C1024QE), -40°C to $+85^{\circ}\text{C}$, and military temperature range (NMC27C1024QM), -55°C to $+125^{\circ}\text{C}$, available
- Pin compatible with NMOS worldwide 1024k EPROMs
- Fast and reliable programming—100 μ s typical/byte
- Static operation—no clocks required
- TTL, CMOS compatible inputs/outputs
- TRI-STATE[®] output
- Optimum EPROM for total CMOS systems
- Manufacturer's Identification Code for automatic programming control
- High current CMOS level output drivers

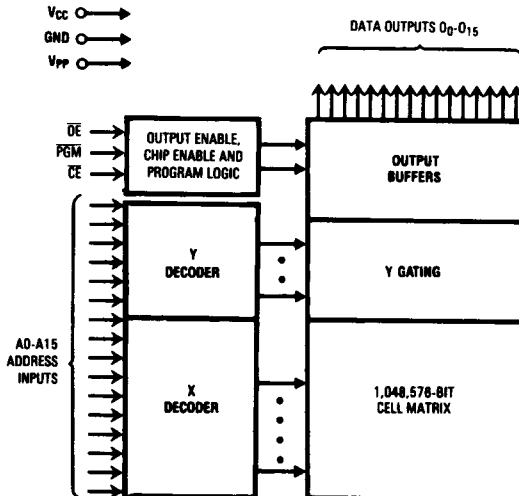
Block Diagram

TL/D/8806-1

Pin Names

Pin Name	Description
A0-A15	Addresses
$\overline{\text{CE}}$	Chip Enable
$\overline{\text{OE}}$	Output Enable
O ₀ -O ₁₅	Outputs
PGM	Program
NC	No Connect

Connection Diagram

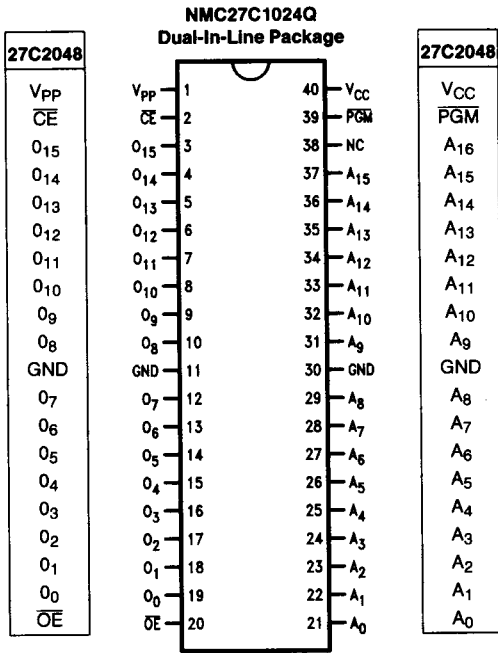

TL/D/8806-2

Order Number NMC27C1024Q
See NS Package Number J40AQ

Note: National's socket compatible EPROM pin configurations are shown in the blocks adjacent to the NMC27C1024 pins.

Commercial Temperature Range (0°C to +70°C)
V_{CC} = 5V ± 5%

Parameter/Order Number	Access Time (ns)
NMC27C1024Q12	120
NMC27C1024Q15	150
NMC27C1024Q17	170
NMC27C1024Q20	200
NMC27C1024Q25	250

Extended Temperature (-40°C to +85°C)
V_{CC} = 5V ± 10%

Parameter/Order Number	Access Time (ns)
NMC27C1024QE150	150
NMC27C1024QE170	170
NMC27C1024QE200	200

Note: Surface mount PLCC package available for commercial and extended temperature ranges only.

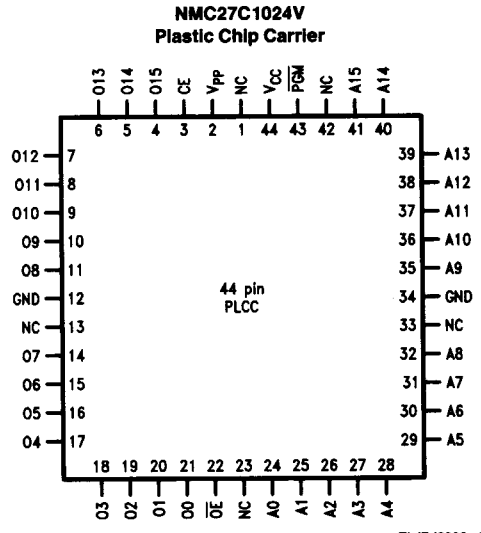

TL/D/8806-11

Order Number NMC27C1024V
See NS Package Number V44A

Commercial Temperature Range (0°C to +70°C)
V_{CC} = 5V ± 10%

Parameter/Order Number	Access Time (ns)
NMC27C1024Q120	120
NMC27C1024Q150	150
NMC27C1024Q170	170
NMC27C1024Q200	200
NMC27C1024Q250	250

Military Temperature Range (-55°C to +125°C)
V_{CC} = 5V ± 10%

Parameter/Order Number	Access Time (ns)
NMC27C1024QM170	170
NMC27C1024QM200	200

COMMERCIAL TEMPERATURE RANGE

Absolute Maximum Ratings (Note 1)

Temperature Under Bias	-10°C to +80°C
Storage Temperature	-65°C to +150°C
All Input Voltages except A9 with Respect to Ground (Note 10)	+6.5V to -0.6V
All Output Voltages with Respect to Ground (Note 10)	V _{CC} +1.0 to GND-0.6V
V _{PP} Supply Voltage and A9 with Respect to Ground During Programming	+14.0V to -0.6V
V _{CC} Supply Voltage with Respect to Ground	+7.0V to -0.6V

Power Dissipation	1.0W
Lead Temperature (Soldering, 10 sec.)	300°C
ESD rating (MiL Spec 883C Method 3015.2)	2000V

Operating Conditions (Note 7)

Temperature Range	0°C to +70°C
V _{CC} Power Supply	
NMC27C1024Q12, 15, 17, 20, 25	+5V ±5%
NMC27C1024Q120, 150, 170, 200, 250	+5V ±10%

READ OPERATION

DC Electrical Characteristics

Symbol	Parameter	Conditions	Min	Typ	Max	Units
I _{LI}	Input Load Current	V _{IN} = V _{CC} or GND			1	μA
I _{LO}	Output Leakage Current	V _{OUT} = V _{CC} or GND, $\overline{CE} = V_{IH}$			1	μA
I _{CC1} (Note 9)	V _{CC} Current (Active) TTL Inputs	$\overline{CE} = V_{IL}$, f = 5 MHz Inputs = V _{IH} or V _{IL} I/O = 0 mA		15	30	mA
I _{CC2} (Note 9)	V _{CC} Current (Active) CMOS Inputs	$\overline{CE} = GND$, f = 5 MHz Inputs = V _{CC} or GND, I/O = 0 mA		13	20	mA
I _{CCSB1}	V _{CC} Current (Standby) TTL Inputs	$\overline{CE} = V_{IH}$		0.1	1	mA
I _{CCSB2}	V _{CC} Current (Standby) CMOS Inputs	$\overline{CE} = V_{CC}$		0.5	100	μA
I _{PP}	V _{PP} Load Current	V _{PP} = V _{CC}			10	μA
V _{IL}	Input Low Voltage		-0.2		0.8	V
V _{IH}	Input High Voltage		2.0		V _{CC} + 1	V
V _{OL1}	Output Low Voltage	I _{OL} = 2.1 mA			0.40	V
V _{OH1}	Output High Voltage	I _{OH} = -2.5 mA	3.5			V
V _{OL2}	Output Low Voltage	I _{OL} = 10 μA			0.1	V
V _{OH2}	Output High Voltage	I _{OH} = -10 μA	V _{CC} - 0.1			V

AC Electrical Characteristics

Symbol	Parameter	Conditions	Q12, Q120		Q15, Q150		Q17, Q170		Q20, Q200		Q25, Q250		Units
			Min	Max	Min	Max	Min	Max	Min	Max	Min	Max	
t _{ACC}	Address to Output Delay	$\overline{CE} = \overline{OE} = V_{IL}$ PGM = V _{IH}		120		150		170		200		250	ns
t _{CE}	\overline{CE} to Output Delay	$\overline{OE} = V_{IL}$ PGM = V _{IH}		120		150		170		200		250	ns
t _{OE}	\overline{OE} to Output Delay	$\overline{CE} = V_{IL}$ PGM = V _{IH}		50		60		75		75		100	ns
t _{DF}	\overline{OE} High to Output Float	$\overline{CE} = V_{IL}$ PGM = V _{IH}	0	40	0	50	0	55	0	55	0	60	ns
t _{CF}	\overline{CE} High to Output Float	$\overline{OE} = V_{IL}$ PGM = V _{IH}	0	40	0	50	0	55	0	55	0	60	ns
t _{OH}	Output Hold from Addresses, \overline{CE} or \overline{OE} , Whichever Occurred First	$\overline{CE} = \overline{OE} = V_{IL}$ PGM = V _{IH}	0		0		0		0		0		ns

MILITARY AND EXTENDED TEMPERATURE RANGE

Absolute Maximum Ratings (Note 1)

If Military/Aerospace specified devices are required, please contact the National Semiconductor Sales Office/Distributors for availability and specifications.

Temperature Under Bias	Operating Temp. Range	
Storage Temperature		-65°C to +150°C
All Input Voltages except A9 with Respect to Ground (Note 10)		+6.5V to -0.6V
All Output Voltages with Respect to Ground (Note 10)	V _{CC} + 1.0V to GND - 0.6V	
V _{PP} Supply Voltage and A9 with Respect to Ground		
During Programming		+14.0V to -0.6V

V _{CC} Supply Voltage with Respect to Ground	+7.0V to -0.6V
Power Dissipation	1.0W
Lead Temperature (Soldering, 10 sec.)	300°C
ESD Rating (Mil Spec 883C, Method 3015.2)	2000V

Operating Conditions (Note 7)

Temperature Range	
NMC27C1024QE150, 170, 200	-40°C to +85°C
NMC27C1024QM170, 200	-55°C to +125°C
V _{CC} Power Supply	+5V ± 10%

READ OPERATION

DC Electrical Characteristics

Symbol	Parameter	Conditions	Min	Typ	Max	Units
I _{LI}	Input Load Current	V _{IN} = V _{CC} or GND			10	μA
I _{LO}	Output Leakage Current	V _{OUT} = V _{CC} or GND, $\overline{CE} = V_{IH}$			10	μA
I _{CC1} (Note 9)	V _{CC} Current (Active) TTL Inputs	$\overline{CE} = V_{IL}$, f = 5 MHz Inputs = V _{IH} or V _{IL} , I/O = 0 mA		15	30	mA
I _{CC2} (Note 9)	V _{CC} Current (Active) CMOS Inputs	$\overline{CE} = GND$, f = 5 MHz Inputs = V _{CC} or GND, I/O = 0 mA		13	20	mA
I _{CCSB1}	V _{CC} Current (Standby) TTL Inputs	$\overline{CE} = V_{IH}$		0.1	1	mA
I _{CCSB2}	V _{CC} Current (Standby) CMOS Inputs	$\overline{CE} = V_{CC}$		0.5	100	μA
I _{PP}	V _{PP} Load Current	V _{PP} = V _{CC}			10	μA
V _{IL}	Input Low Voltage		-0.2		0.8	V
V _{IH}	Input High Voltage		2.0		V _{CC} + 1	V
V _{OL1}	Output Low Voltage	I _{OL} = 2.1 mA			0.40	V
V _{OH1}	Output High Voltage	I _{OH} = -1.6 mA	3.5			V
V _{OL2}	Output Low Voltage	I _{OL} = 10 μA			0.1	V
V _{OH2}	Output High Voltage	I _{OH} = -10 μA	V _{CC} - 0.1			V

AC Electrical Characteristics

Symbol	Parameter	Conditions	NMC27C1024Q						Units
			E150		E170, M170		E200, M200		
			Min	Max	Min	Max	Min	Max	
t _{ACC}	Address to Output Delay	$\overline{CE} = \overline{OE} = V_{IL}$ PGM = V _{IH}		150		170		200	ns
t _{CE}	\overline{CE} to Output Delay	$\overline{OE} = V_{IL}$, PGM = V _{IH}		150		170		200	ns
t _{OE}	\overline{OE} to Output Delay	$\overline{CE} = V_{IL}$, PGM = V _{IH}		60		75		75	ns
t _{DF}	\overline{OE} High to Output Float	$\overline{CE} = V_{IL}$, PGM = V _{IH}	0	50	0	55	0	55	ns
t _{CF}	\overline{CE} High to Output Float	$\overline{OE} = V_{IL}$, PGM = V _{IH}	0	50	0	55	0	55	ns
t _{OH}	Output Hold from Addresses, \overline{CE} or \overline{OE} , Whichever Occurred First	$\overline{CE} = \overline{OE} = V_{IL}$ PGM = V _{IH}	0		0		0		ns

Capacitance $T_A = +25^\circ\text{C}$, $f = 1\text{ MHz}$ (Note 2)

Symbol	Parameter	Conditions	Typ	Max	Units
C_{IN}	Input Capacitance	$V_{IN} = 0\text{V}$	12	20	pF
C_{OUT}	Output Capacitance	$V_{OUT} = 0\text{V}$	13	20	pF

AC Test Conditions

Output Load 1 TTL Gate and $C_L = 100\text{ pF}$ (Note 8)

Input Rise and Fall Times $\leq 5\text{ ns}$

Input Pulse Levels 0.45V to 2.4V

Timing Measurement Reference Level

Inputs 0.8V and 2V

Outputs 0.8V and 2V

AC Waveforms (Notes 6, 7, & 9)

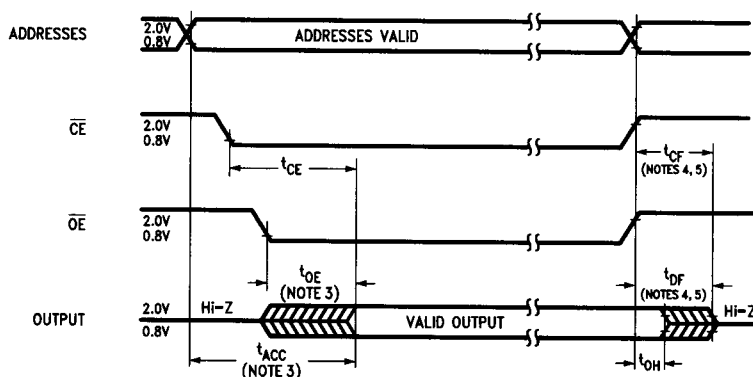

TL/D/8806-3

Note 1: Stresses above those listed under "Absolute Maximum Ratings" may cause permanent damage to the device. This is a stress rating only and functional operation of the device at these or any other conditions above those indicated in the operational sections of this specification is not implied. Exposure to absolute maximum rating conditions for extended periods may affect device reliability.

Note 2: This parameter is only sampled and is not 100% tested.

Note 3: \overline{OE} may be delayed up to $t_{ACC} - t_{OE}$ after the falling edge of \overline{CE} without impacting t_{ACC} .

Note 4: The t_{DF} and t_{CF} compare level is determined as follows:

High to TRI-STATE, the measured V_{OH1} (DC) - 0.10V

Low to TRI-STATE, the measured V_{OL1} (DC) + 0.10V

Note 5: TRI-STATE may be attained using \overline{OE} or \overline{CE} .

Note 6: The power switching characteristics of EPROMs require careful device decoupling. It is recommended that at least a 0.1 μF ceramic capacitor be used on every device between V_{CC} and GND.

Note 7: The outputs must be restricted to $V_{CC} + 1.0\text{V}$ to avoid latch-up and device damage.

Note 8: 1 TTL Gate: $I_{OL} = 1.6\text{ mA}$, $I_{OH} = -400\text{ }\mu\text{A}$.

CL: 100 pF includes fixture capacitance.

Note 9: V_{PP} may be connected to V_{CC} except during programming.

Note 10: Inputs and outputs can undershoot to -2.0V for 20 ns max.

Programming Characteristics (Notes 1, 2, 3 & 4)

Symbol	Parameter	Conditions	Min	Typ	Max	Units
t_{AS}	Address Set-Up Time		1			μs
t_{OES}	\overline{OE} Set-Up Time		1			μs
t_{CES}	\overline{CE} Set-Up Time		1			μs
t_{DS}	Data Set-Up Time		1			μs
t_{VPS}	V_{PP} Set-Up Time		1			μs
t_{VCS}	V_{CC} Set-Up Time		1			μs
t_{AH}	Address Hold Time		0			μs
t_{DH}	Data Hold Time		1			μs
t_{DF}	Output Enable to Output Float Delay	$\overline{CE} = V_{IL}$	0		60	ns
t_{PW}	Program Pulse Width		95	100	105	μs
t_{OE}	Data Valid From \overline{OE}	$\overline{CE} = V_{IL}$			100	ns
I_{PP}	V_{PP} Supply Current during Programming Pulse	$\overline{CE} = V_{IL}$ $\text{PGM} = V_{IL}$			60	mA
I_{CC}	V_{CC} Supply Current				10	mA
t_R	Temp Ambient		20	25	30	$^{\circ}\text{C}$
V_{CC}	Power Supply Voltage		6.0	6.25	6.5	V
V_{PP}	Programming Supply Voltage		12.5	12.75	13.0	V
T_{CR}	Input Rise, Fall Time		5			ns
V_{IL}	Input Low Voltage			0.0	0.45	V
V_{IH}	Input High Voltage		2.4	4.0		V
t_{IN}	Input Timing Reference Voltage		0.8	1.5	2.0	V
t_{OUT}	Output Timing Reference Voltage		0.8	1.5	2.0	V

Programming Waveforms (Note 3)

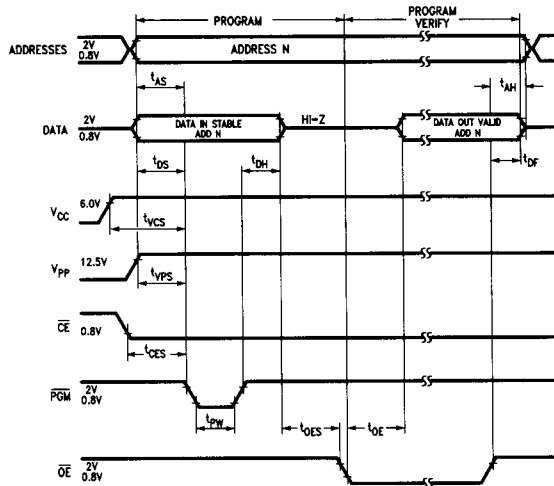

TL/D/8806-10

Note 1: National's standard product warranty applies only to devices programmed to specifications described herein.

Note 2: V_{CC} must be applied simultaneously or before V_{PP} and removed simultaneously or after V_{PP} . The EPROM must not be inserted into or removed from a board with voltage applied to V_{PP} or V_{CC} .

Note 3: The maximum absolute allowable voltage which may be applied to the V_{PP} pin during programming is 14V. Care must be taken when switching the V_{PP} supply to prevent any overshoot from exceeding this 14V maximum specification. At least a 0.1 μF capacitor is required across V_{PP} , V_{CC} to GND to suppress spurious voltage transients which may damage the device.

Note 4: Programming and program verify are tested with the Fast Program Algorithm, at typical power supply voltages and timings.

Fast Programming Algorithm Flow Chart

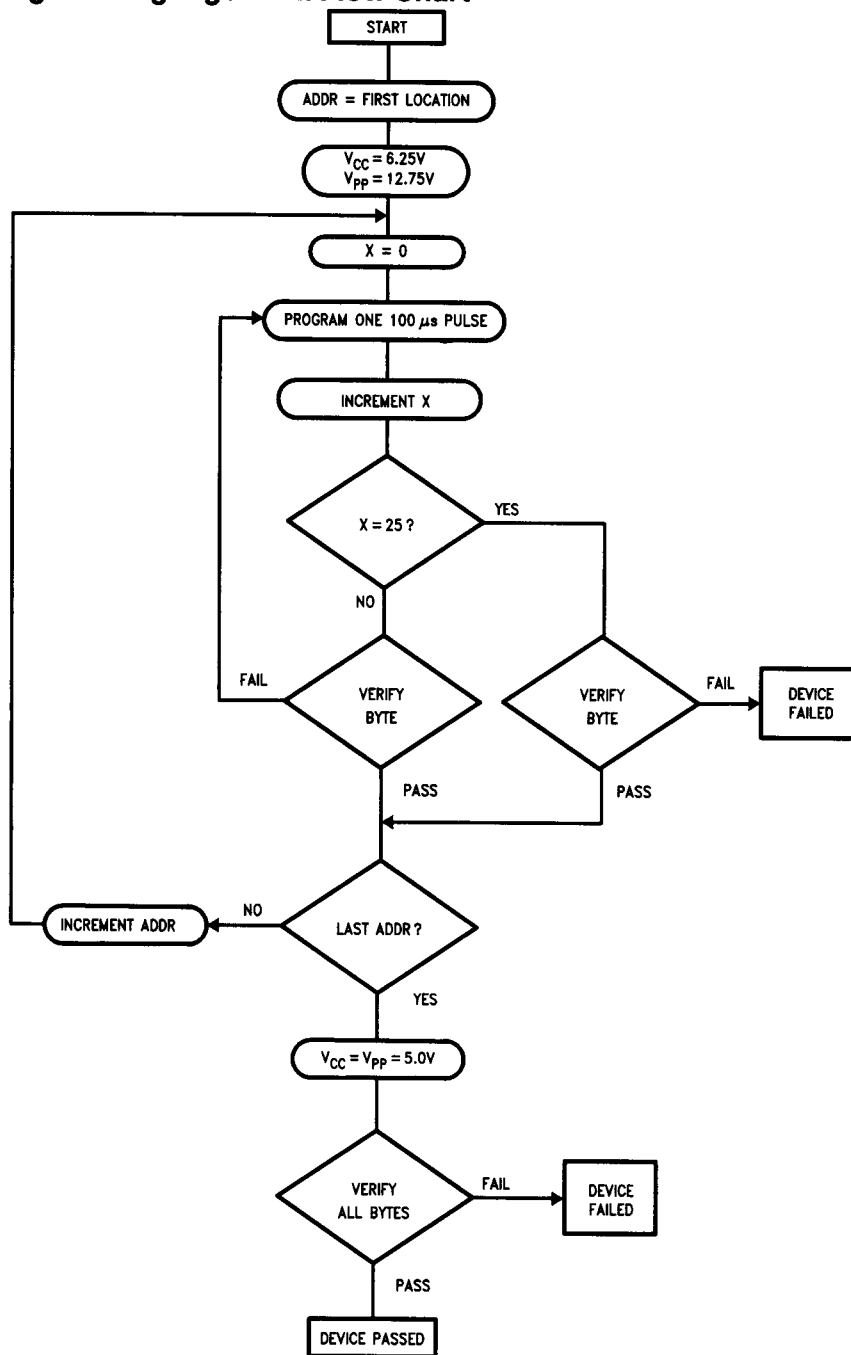

FIGURE 1

TL/D/8806-5

Functional Description

DEVICE OPERATION

The six modes of operation of the NMC27C1024 are listed in Table I. It should be noted that all inputs for the six modes are at TTL levels. The power supplies required are V_{CC} and V_{PP} . The V_{PP} power supply must be at 12.75V during the three programming modes, and must be at 5V in the other three modes. The V_{CC} power supply must be at 6.25V during the three programming modes, and at 5V in the other three modes.

Read Mode

The NMC27C1024 has two control functions, both of which must be logically active in order to obtain data at the outputs. Chip Enable (\overline{CE}) is the power control and should be used for device selection. Output Enable (\overline{OE}) is the output control and should be used to gate data to the output pins, independent of device selection. Assuming that addresses are stable, address access time (t_{ACC}) is equal to the delay from \overline{CE} to output (t_{CE}). Data is available at the outputs t_{OE} after the falling edge of \overline{OE} , assuming that \overline{CE} has been low and addresses have been stable for at least $t_{ACC}-t_{OE}$.

The sense amps are clocked for fast access time. V_{CC} should therefore be maintained at operating voltage during read and verify. If V_{CC} temporarily drops below the spec. voltage (but not to ground) an address transition must be performed after the drop to ensure proper output data.

Standby Mode

The NMC27C1024 has a standby mode which reduces the active power dissipation by over 99%, from 110 mW to 0.55 mW. The NMC27C1024 is placed in the standby mode by applying a CMOS high signal to the \overline{CE} input. When in standby mode, the outputs are in a high impedance state, independent of the \overline{OE} input.

Output OR-Tying

Because NMC27C1024s are usually used in larger memory arrays, National has provided a 2-line control function that accommodates this use of multiple memory connections. The 2-line control function allows for:

- the lowest possible memory power dissipation, and
- complete assurance that output bus contention will not occur.

To most efficiently use these two control lines, it is recommended that \overline{CE} (pin 2) be decoded and used as the primary device selecting function, while \overline{OE} (pin 20) be made a common connection to all devices in the array and connected to the READ line from the system control bus. This assures that all deselected memory devices are in their low power standby modes and that the output pins are active only when data is desired from a particular memory device.

Programming

CAUTION: Exceeding 14V on the V_{PP} or A9 pin will damage the NMC27C1024.

Initially, and after each erasure, all bits of the NMC27C1024 are in the "1" state. Data is introduced by selectively programming "0's" into the desired bit locations. Although only "0's" will be programmed, both "1's" and "0's" can be presented in the data word. The only way to change a "0" to a "1" is by ultraviolet light erasure.

The NMC27C1024 is in the programming mode when the V_{PP} power supply is at 12.75V and \overline{OE} is at V_{IH} . It is required that at least a 0.1 μF capacitor be placed across V_{PP} , V_{CC} to ground to suppress spurious voltage transients which may damage the device. The data to be programmed is applied 16 bits in parallel to the data output pins. The levels required for the address and data inputs are TTL.

When the address and data are stable, an active low, TTL program pulse is applied to the PGM input. A program pulse must be applied at each address location to be programmed. The NMC27C1024 is programmed with the Fast Programming Algorithm shown in Figure 1. Each Address is programmed with a series of 100 μs pulses until it verifies good, up to a maximum of 25 pulses. Most memory cells will program with a single 100 μs pulse. The NMC27C1024 must not be programmed with a DC signal applied to the PGM input.

Programming multiple NMC27C1024s in parallel with the same data can be easily accomplished due to the simplicity of the programming requirements. Like inputs of the parallel NMC27C1024s may be connected together when they are programmed with the same data. A low level TTL pulse applied to the PGM input programs the paralleled NMC27C1024s.

TABLE I. Mode Selection

Mode	Pins	\overline{CE} (2)	\overline{OE} (20)	PGM (39)	V_{PP} (1)	V_{CC} (40)	Outputs (3-10, 12-19)
	Read		V_{IL}	V_{IL}	V_{IH}	V_{CC}	5V
Standby		V_{IH}	Don't Care	Don't Care	V_{CC}	5V	Hi-Z
Output Disable		Don't Care	V_{IH}	V_{IH}	V_{CC}	5V	Hi-Z
Program		V_{IL}	V_{IH}	V_{IL}	12.75V	6.25V	D_{IN}
Program Verify		V_{IL}	V_{IL}	V_{IH}	12.75V	6.25V	D_{OUT}
Program Inhibit		V_{IH}	Don't Care	Don't Care	12.75V	6.25V	Hi-Z

Functional Description (Continued)

Program Inhibit

Programming multiple NMC27C1024s in parallel with different data is also easily accomplished. Except for \overline{CE} , all like inputs (including \overline{OE} and \overline{PGM}) of the parallel NMC27C1024 may be common. A TTL low level program pulse applied to an NMC27C1024 \overline{PGM} input with \overline{CE} at V_{IL} and V_{PP} at 12.5V will program that NMC27C1024. A TTL high level \overline{CE} input inhibits the other NMC27C1024s from being programmed.

Program Verify

A verify should be performed on the programmed bits to determine whether they were correctly programmed. The verify may be performed with V_{PP} at 12.5V. V_{PP} must be at V_{CC} except during programming and program verify.

Manufacturer's Identification Code

The NMC27C1024 has a manufacturer's identification code to aid in programming. When the device is inserted in an EPROM programmer socket, the programmer reads the code and then automatically calls up the specific programming algorithm for the part. This automatic programming control is only possible with programmers which have the capability of reading the code.

The Manufacturer's Identification code, shown in Table II, specifically identifies the manufacturer and the device type. The code for the NMC27C1024 is "8FD6", where "8F" designates that it is made by National Semiconductor, and "D6" designates a 1 Meg part.

The code is accessed by applying $12 \pm 0.5V$ to address pin A9. Addresses A1–A8, A10–A15, and all control pins are held at V_{IL} . Address pin A0 is held at V_{IL} for the manufacturer's code, and held at V_{IH} for the device code. The code is read on the lower eight data pins, O₀–O₇. Proper code access is only guaranteed at $25^\circ C \pm 5^\circ C$.

ERASURE CHARACTERISTICS

The erasure characteristics of the NMC27C1024 are such that erasure begins to occur when exposed to light with wavelengths shorter than approximately 4000 Angstroms (\AA). It should be noted that sunlight and certain types of fluorescent lamps have wavelengths in the 3000 \AA –4000 \AA range. After programming opaque labels should be placed

over the NMC27C1024 window to prevent unintentional erasure. Covering the window will also prevent temporary functional failure due to the generation of photo currents.

The recommended erasure procedure for the NMC27C1024 is exposure to short wave ultraviolet light which has a wavelength of 2537 Angstroms (\AA). The integrated dose (i.e., UV intensity x exposure time) for erasure should be a minimum of 15W-sec/cm².

The NMC27C1024 should be placed within 1 inch of the lamp tubes during erasure. Some lamps have a filter on their tubes which should be removed before erasure. Table III shows the minimum NMC27C1024 erasure time for various light intensities.

An erasure system should be calibrated periodically. The distance from lamp to unit should be maintained at one inch. The erasure time increases as the square of the distance. (If distance is doubled the erasure time increases by a factor of 4.) Lamps lose intensity as they age. When a lamp is changed, the distance has changed, or the lamp has aged, the system should be checked to make certain full erasure is occurring. Incomplete erasure will cause symptoms that can be misleading. Programmers, components, and even system designs have been erroneously suspected when incomplete erasure was the problem.

SYSTEM CONSIDERATION

The power switching characteristics of EPROMs require careful decoupling of the devices. The supply current, I_{CC} , has three segments that are of interest to the system designer—the standby current level, the active current level, and the transient current peaks that are produced by voltage transitions on input pins. The magnitude of these transient current peaks is dependent on the output capacitance loading of the device. The associated V_{CC} transient voltage peaks can be suppressed by properly selected decoupling capacitors. It is recommended that at least a 0.1 μF ceramic capacitor be used on every device between V_{CC} and GND. This should be a high frequency capacitor of low inherent inductance. In addition, at least a 4.7 μF bulk electrolytic capacitor should be used between V_{CC} and GND for each eight devices. The bulk capacitor should be located near where the power supply is connected to the array. The purpose of the bulk capacitor is to overcome the voltage drop caused by the inductive effects of the PC board traces.

TABLE II. Manufacturer's Identification Code

Pins	A ₀ (21)	O ₇ (12)	O ₆ (13)	O ₅ (14)	O ₄ (15)	O ₃ (16)	O ₂ (17)	O ₁ (18)	O ₀ (19)	Hex Data
Manufacturer Code	V_{IL}	1	0	0	0	1	1	1	1	8F
Device Code	V_{IH}	1	1	0	1	0	1	1	0	D6

TABLE III. Minimum NMC27C1024 Erasure Time

Light Intensity (Micro-Watts/cm ²)	Erasure Time (Minutes)
15,000	20
10,000	25
5,000	50

1