

**SAA1250, SAA1251 IC Kit for 64 Channel Infrared Remote Control (both in 24-Pin Plastic Package)**

**SAA1250:** Transmitter IC in CMOS Technology  
**SAA1251:** Receiver IC in P-Channel Si-Gate Technology

This IC kit, developed for the remote control of television and radio receivers is based on an interference-rejecting infrared transmission principle. It consumes a minimal current at the transmitting end and, due to its large instruction repertoire is highly flexible in application. This is why it may also be employed for industrial remote-control. Pulse-sequence modulated infrared light serves for the transmission of remote-control commands, the information being defined by the varying time intervals between a sequence of very short infrared pulses. This enables the emitter diode to be driven with a high current (1 A or more), thus achieving a large transmission distance and high interference immunity while ensuring a long battery life.

A photo-diode converts the received IR-transmissions into electrical signals. These are then amplified and fed to the receiver IC SAA1251, where certain signals are converted into command signals for television and wireless receivers, e.g. for on/off switching, choice of program and for the setting of four analog control values such as volume, brightness etc. All the received signals appear on the data output DA of the SAA1251 in amplitude-modulated form and may be processed further by the adapter IC SAA1272.

Each remote-control signal word contains ten information bits. The transmitter IC SAA1250, therefore, is capable of delivering 1024 different signals. The word is usually structured into four bits and six bits offering 16 addresses and 64 commands. However, this separation must by no means be rigidly adhered to. The receiver IC allows an operational mode in which commands for calling up subsystems are also used. So, the number of transmittable commands and addressable additional integrated circuits becomes practically unlimited.

The signals are transmitted by means of infrared light in the shape of packaged pulses. For the transmission of a 10-bit word, 14 pulses are required. The binary information of a bit is contained in the time interval between two pulses. We define the time T (approx. 100  $\mu$ s) as the basis for the code to be employed. A short interval of duration T between any two pulses corresponds to the binary digit "0", while a long interval of the duration 2T signifies the binary digit "1". For a 10-bit word, 11 data pulses are therefore required. In addition, every signal contains a preliminary pulse, a start pulse and a stop pulse. The spacing between preliminary pulse and start pulse is 3T. This is followed after 1T by the 11 data pulses and terminated after a 3T interval by the stop pulse.

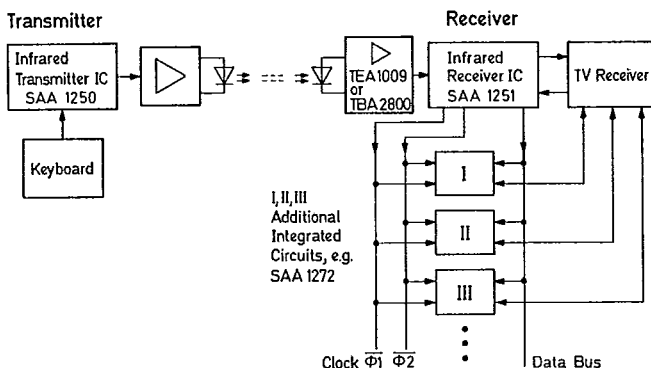

**Infrared Remote Control System with SAA1250, SAA1251**

**SAA1272 Programmable Adapter-IC for the Infrared Receiver-IC SAA1251 (18-Pin Plastic Package)**

MOS circuit in N-channel silicon-gate depletion-load technology that processes the serial information delivered at the data output DA of the SAA1251 infrared receiver circuit, e.g. for the application in text decoders.

The SAA1272 recognizes the address, stores the six control bits, and delivers the signals for a 7-bit MIBUS or a 7-bit IBUS. The output code is mask programmable.

The first four bits of the command word from the SAA1251 are considered as an address by the SAA1272 and checked. Addresses 1 or 16 will be stored, any other address is ignored, and the evaluation of the command word interrupted.

If address 1 or 16 has been recognized, the following six control bits are taken as command and stored temporarily in a 6-bit shift register. The command is decoded in a decoder ROM depending on setting of the subsystems, stored address and the "output option" and "bus mode" signals (pins 16 and 17). These relations are mask programmable. At a maximum, 80 commands may be decoded in the various dependencies.

If a command cannot be decoded, the SAA1272 interrupts decoding and waits for another command word. If a command is decoded, this command selects a certain address in an encoder ROM which is mask programmed for a certain output code. An output shift register takes the output signal and delivers it via pin 5 in a serial form.

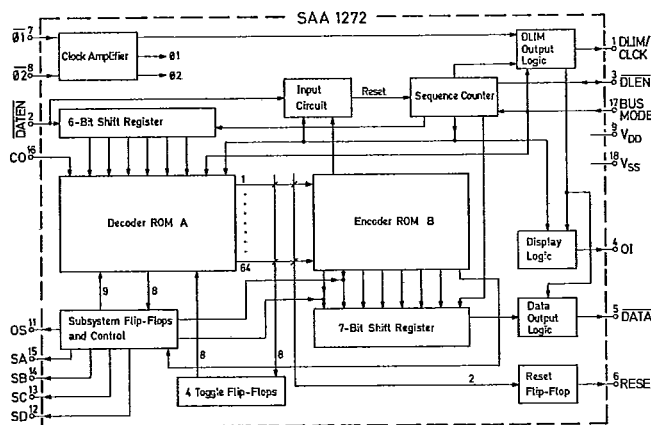

**SAA1272 Block Diagram**