

Bipolar circuit

Fast ECL divider with constant dividing ratio 1:64 covering the frequency range from 80 MHz to 1 GHz. The SDA 2001 includes a broadband preamplifier with approx. 20 dB voltage gain and two separate inputs for UHF and VHF, which can be selected by external dc voltage.

- Input frequency up to 1 GHz
- Integrated preamplifier
- Balanced output in phase opposition

Type	Ordering code	Package outline
SDA 2001	Q67000-A1464	DIP 18

Maximum ratings

Supply voltage	V_S	10	V
Input voltage	V_{i4}, V_{i5}	1	V
Output current	I_{q8}, I_{q9}	-2.1	mA
Junction temperature	T_j	150	°C
Storage temperature range	T_{stg}	-40 to 125	°C
Thermal resistance (system-air)	$R_{th SA}$	70	K/W

Range of operation

Supply voltage range	V_S	6.45 to 7.15	V
Ambient temperature range	T_{amb}	0 to 70	°C

Characteristics ($V_S = 6.8\text{ V}$; $T_{amb} = 25\text{ }^\circ\text{C}$)

		min	typ	max	
Current consumption	I_7	75	105	140	mA
Input voltage range	$f_i = 100\text{ MHz}$	V_{i4}	35	500	mV
	$f_i = 200\text{ MHz}$	V_{i4}	20	500	mV
	$f_i = 470\text{ MHz}$	V_{i5}	20	300	mV
	$f_i = 900\text{ MHz}$	V_{i5}	35	100	mV
	Maximum $f_{i\text{ max}}$	f_{i5}	950	1100	
Input frequency	Minimum $f_{i\text{ min}}$	f_{i4}	60	80	MHz
		V_{q8}, V_{q9}	600	800	1000
Output voltage				0.6	V
L-changeover voltage	V_{2L}				V
H-changeover voltage	V_{2H}	3			V
Changeover current ($V_2 = 12\text{ V}$)	$-I_2$		1.5		mA
Output resistance	R_q		250		Ω

Input voltage ratings are measured with Vector-voltmeter 8405 A at amplifier input.

Test circuit

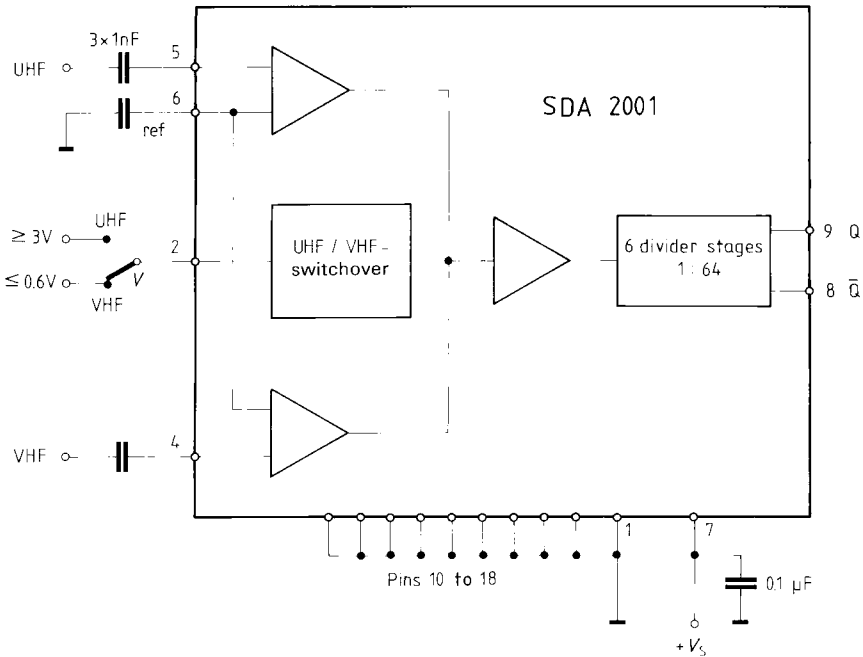

Block diagram incl. internal pin configuration

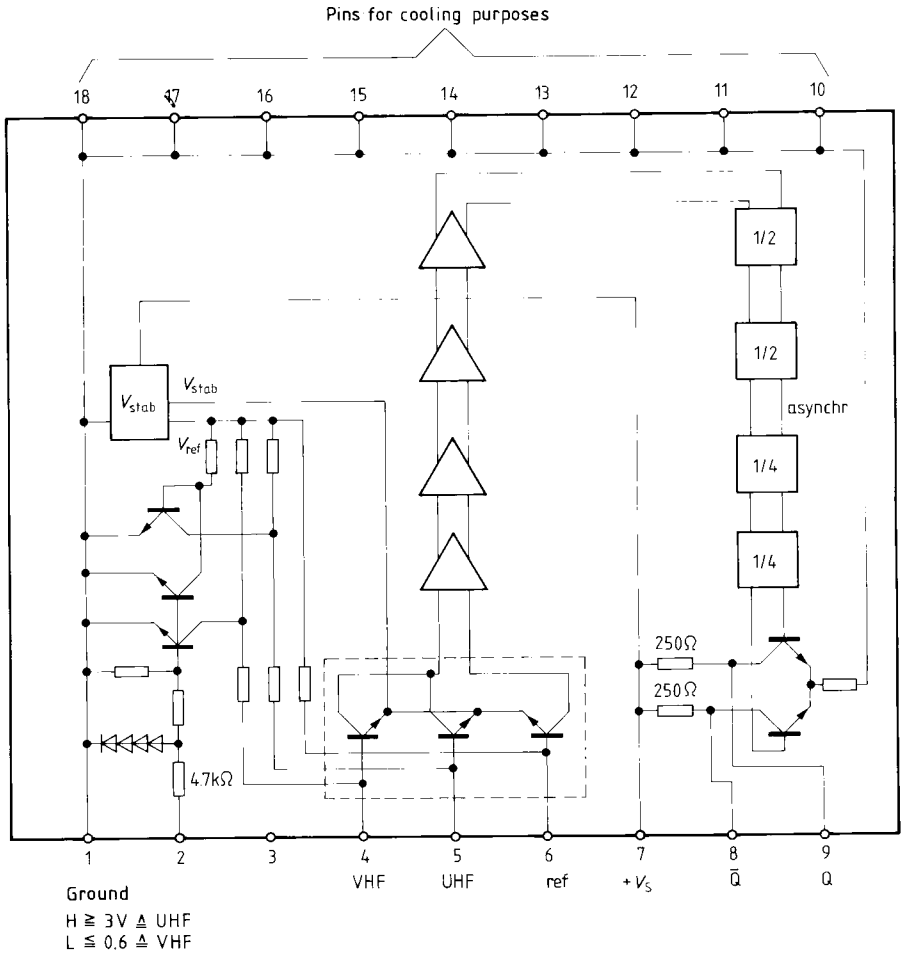

Input impedance behavior versus frequency

$Z_0 = 75 \Omega$, measured asymmetrically

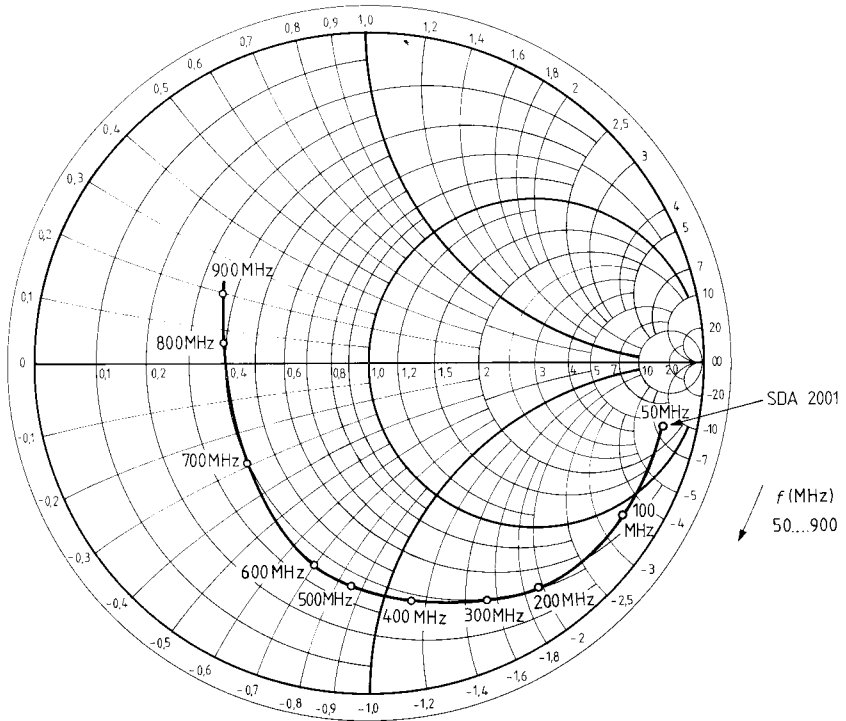

Decoupling of the VHF and UHF input versus input frequency

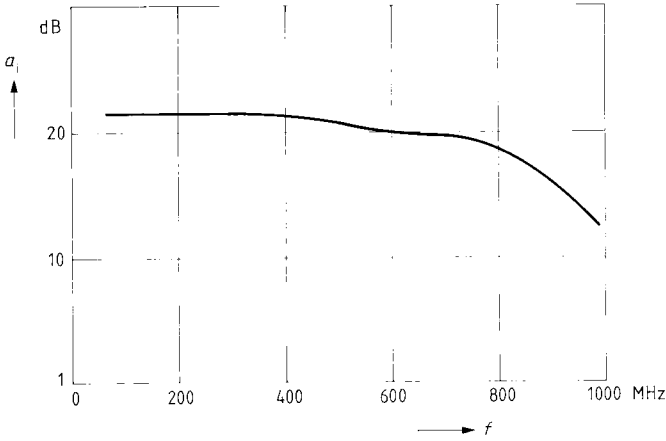

Input sensitivity versus input frequency

