

54LS/74LS245 (Preliminary Data)

PIN CONFIGURATION

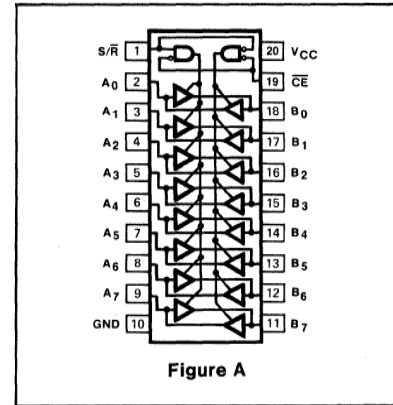

Figure A

ORDERING CODE (See Section 9 for further Package and Ordering Information)

PACKAGES	PIN CONF.	COMMERCIAL RANGES $V_{CC}=5V \pm 5\%$; $T_A=0^\circ C$ to $+70^\circ C$	MILITARY RANGES $V_{CC}=5V \pm 10\%$; $T_A=-55^\circ C$ to $+125^\circ C$
Plastic DIP	Fig. A	N74LS245N	
Ceramic DIP	Fig. A	N74LS245F	S54LS245F
Flatpak			

FUNCTION TABLE

INPUTS		INPUTS/OUTPUTS	
\overline{CE}	S/R	A_n	B_n
L	L	A = B	INPUTS
L	H	INPUT	B = A
H	X	(Z)	(Z)

H = HIGH voltage level
 L = LOW voltage level
 X = Don't care
 (Z) = High impedance "off" state

INPUT AND OUTPUT LOADING AND FAN-OUT TABLE^(a)

PINS	54/74	54H/74H	54S/74S	54LS/74LS
Inputs	I_{IH} (μA)			20
	I_{IL} (mA)			-0.2
Outputs	I_{OH} (μA)			-12/-15 ^(a)
	I_{OL} (mA)			12/24 ^(a)

DC CHARACTERISTICS OVER OPERATING TEMPERATURE RANGE^(b)

PARAMETER	TEST CONDITIONS	54/74		54H/74H		54S/74S		54LS/74LS		UNIT
		Min	Max	Min	Max	Min	Max	Min	Max	
V_{OH} Output HIGH voltage	$V_{CC} = \text{Min}$ $V_{IN} = 2V$ $V_{CE} = V_{IL}$	$I_{OH} = -3.0mA$						2.4		V
		$I_{OH} = -12mA$						2.0		V
		$I_{OH} = -15mA^{(c)}$						2.0		V
V_{OL} Output LOW voltage	$V_{CC} = \text{Min}$ $V_{IN} = V_{IL}$ $V_{CE} = V_{IL}$	$I_{OL} = 12mA$						0.4		V
		$I_{OL} = 24mA^{(c)}$						0.5		V
I_{OS} Output short circuit current	$V_{CC} = \text{Max}, V_{OUT} = 0V$							-40	-120	mA
I_{CCH} Supply current HIGH	$V_{CC} = \text{Max}, V_A = 4.5V$ $V_{CE} = 0V, V_{S/R} = 0V$							70		mA
I_{CCL} Supply current LOW	$V_{CC} = \text{Max}, V_A = 0V$ $V_{CE} = 0V, V_{S/R} = 0V$							90		mA
I_{CCZ} Supply current "off"	$V_{CC} = \text{Max}, V_A = V_B = \text{open}$ $V_{CE} = 4.5V, V_{S/R} = 0V$							95		mA

NOTES

- a. The slashed numbers indicate different parametric values for Military/Commercial temperature ranges respectively.
- b. For family dc characteristics see inside front cover for 54/74 and 54H/74H, and see inside back cover for 54S/74S and 54LS/74LS specification.
- c. This parameter for Commercial Range only.