

LINEAR INTEGRATED CIRCUIT

TAA 611A

AUDIO AMPLIFIER

- OUTPUT POWER 1.8 W (9 V - 4 Ω)
- LOW DISTORTION
- LOW QUIESCENT CURRENT
- HIGH INPUT IMPEDANCE

The TAA 611 A is a monolithic integrated circuit in a 14-lead quad in-line plastic package or in a TO-100 metal case.

It is particularly designed for use in radio receivers and record-players as audio amplifier. The usable range of supply voltage varies from 6 V to 12 V and the circuit requires a minimum number of external components.

ABSOLUTE MAXIMUM RATINGS

ABSOLUTE MAXIMUM RATINGS		TAA 611 A12	TAA 611 A55
V_s	Supply voltage	12 V	
V_i^*	Input voltage	-0.5 to 12 V	
i_o	Output peak current	1 A	
$\rightarrow P_{tot}$	Power dissipation at $T_{amb} \leq 25^\circ\text{C}$	1.35 W	0.57 W
	at $T_{case} \leq 70^\circ\text{C}$	—	1.6 W
	at $T_{case} \leq 100^\circ\text{C}$	3.1 W	—
$\rightarrow T_{stg}, T_j$	Storage and junction temperature	-40 to 150°C	

* For $V_s < 12\text{ V}$, $V_{i\text{ max}} = V_s$

ORDERING NUMBERS: TAA 611 A55 (for TO-100 metal case)
TAA 611 A12 (for quad in-line plastic package)

MECHANICAL DATA

Dimensions in mm

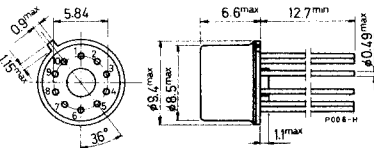

TAA 611 A55

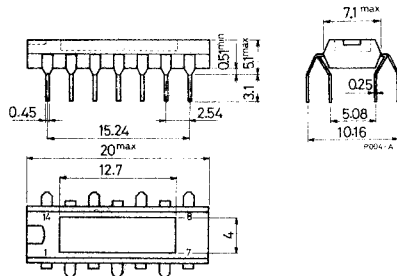

TAA 611 A12

TAA 611A

CONNECTION DIAGRAMS

For TAA 611 A12

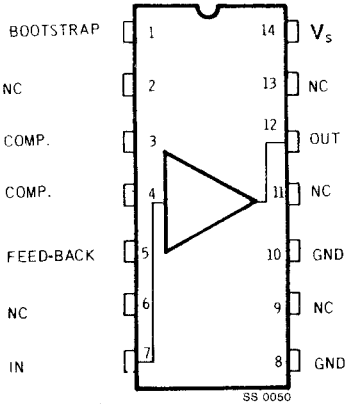

For TAA 611 A55

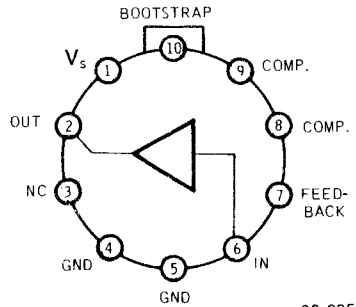

SCHEMATIC DIAGRAM

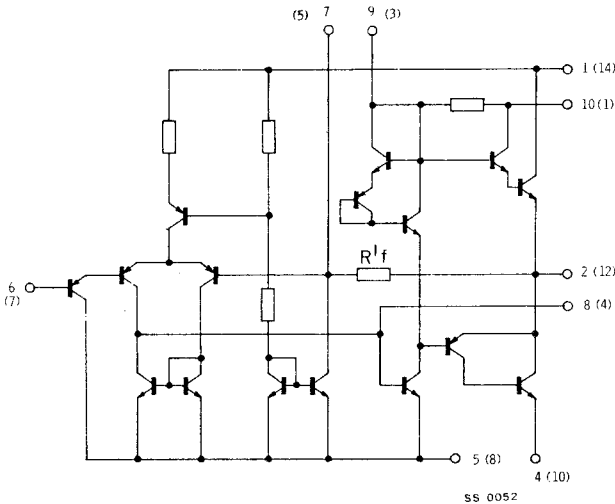

The pin numbers in brackets refer to the TAA 611 A12 and those without brackets refer to the TAA 611 A55.

TAA 611A

TEST CIRCUITS

Circuit No. 1 ($G_v = 50$)

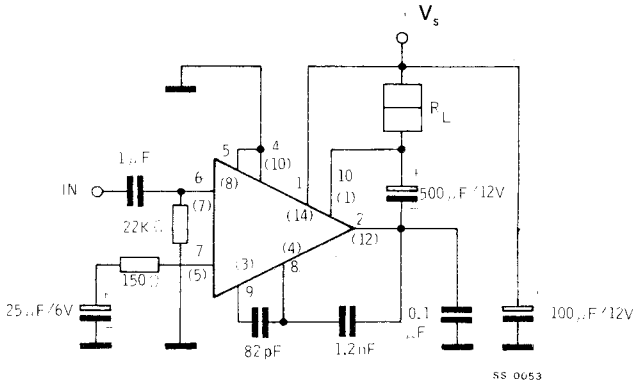

Circuit No. 2 ($G_v = 250$)

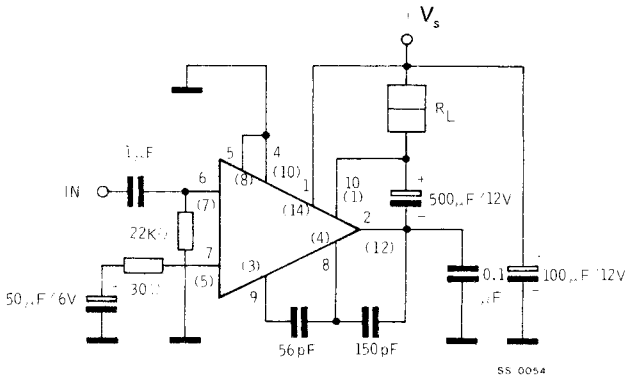

TAA 611A

THERMAL DATA (maximum values)		TAA 611 A12	TAA 611 A55
→ $R_{th\ j-case}$	Thermal resistance junction-case	16 °C/W	50 °C/W
$R_{th\ j-amb}$	Thermal resistance junction-ambient	93 °C/W	220 °C/W

ELECTRICAL CHARACTERISTICS

($T_{amb} = 25\text{ °C}$, $V_s = 9\text{ V}$, refer to the test circuit no. 2 unless otherwise specified)

Parameter	Test conditions	Min.	Typ.	Max.	Unit
V_o	Quiescent output voltage		4.8		V
I_d	Total quiescent drain current		3		mA
I_d	Quiescent drain current of output transistors		1		mA
I_d	Drain current	$P_o = 1.15\text{ W}$		170	mA
→ I_b	Input bias current		0.1	0.8	μA
→ P_o^*	Output power	$d = 2\%$ $f = 1\text{ kHz}$			
		$V_s = 6\text{ V}$ $R_L = 4\ \Omega$	0.50		W
		$V_s = 6\text{ V}$ $R_L = 8\ \Omega$	0.35		W
		$V_s = 9\text{ V}$ $R_L = 4\ \Omega$	1.4		W
		$V_s = 9\text{ V}$ $R_L = 8\ \Omega$	0.9		W
		$d = 10\%$ $f = 1\text{ kHz}$			
		$V_s = 6\text{ V}$ $R_L = 4\ \Omega$	0.65		W
		$V_s = 6\text{ V}$ $R_L = 8\ \Omega$	0.45		W
		$V_s = 9\text{ V}$ $R_L = 4\ \Omega$	1.8		W
		$V_s = 9\text{ V}$ $R_L = 8\ \Omega$	0.85	1.15	W
R_f'	Internal feedback resistance (see schematic diagram)		7.5		kΩ
→ Z_i	Input impedance (open loop)		5		MΩ

TAA 611A

ELECTRICAL CHARACTERISTICS (continued)

Parameter	Test conditions	Min.	Typ.	Max.	Unit
d Distortion	Test circuit 1				
	$P_o = 50 \text{ mW}$	$V_s = 9 \text{ V}$			
	$R_L = 8 \Omega$	$f = 1 \text{ kHz}$	0.4		%
	$P_o = 0.5 \text{ W}$	$V_s = 9 \text{ V}$			
	$R_L = 8 \Omega$	$f = 1 \text{ kHz}$	0.3		%
	Test circuit 2				
$P_o = 50 \text{ mW}$	$V_s = 9 \text{ V}$				
$R_L = 8 \Omega$	$f = 1 \text{ kHz}$	1.7		%	
$P_o = 0.5 \text{ W}$	$V_s = 9 \text{ V}$				
$R_L = 8 \Omega$	$f = 1 \text{ kHz}$	1.2		%	
G_v Voltage gain (open loop)	$R_L = 8 \Omega$		68		dB

* External heatsink not required except for TAA 611 A55 at $V_s = 9 \text{ V}$, $R_L = 4 \Omega$

Fig. 1 - Typical output power vs load resistance

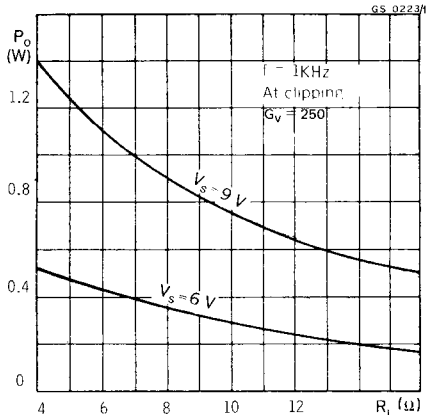
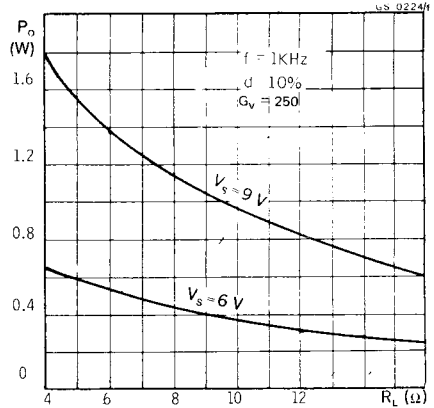

Fig. 2 - Typical output power vs load resistance



TAA 611A

Fig. 3 - Typical distortion vs output power

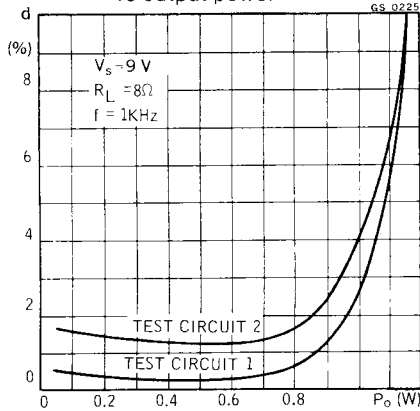

Fig. 4 - Typical distortion vs output power

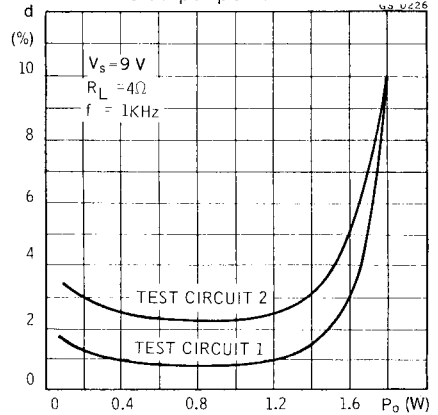

Fig. 5 - Typical relative frequency response

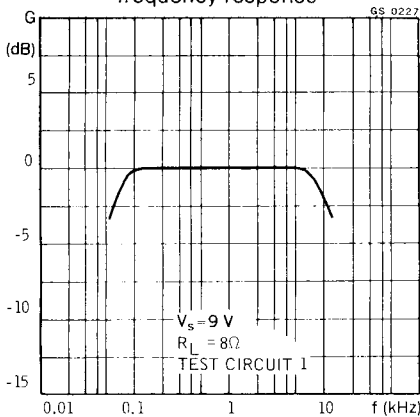
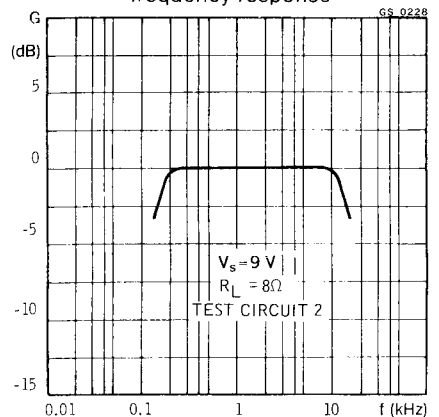

Fig. 6 - Typical relative frequency response



TAA 611A

Fig. 7 - Typical voltage gain (open loop) vs frequency

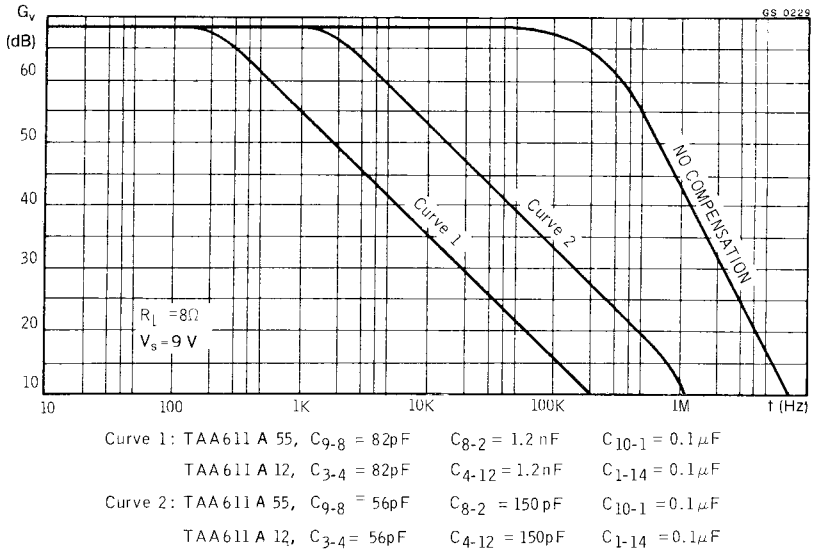

Fig. 8 - Typical output power vs input voltage

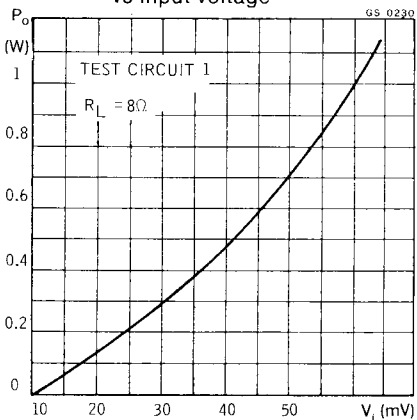
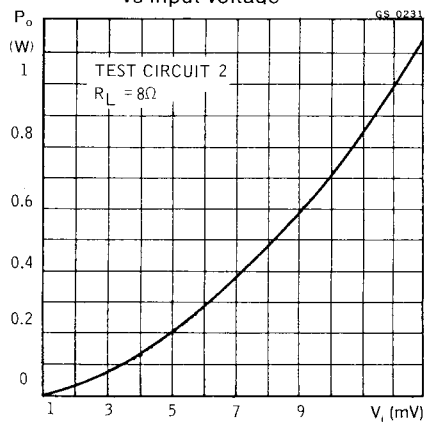

Fig. 9 - Typical output power vs input voltage



TAA 611A

Fig. 10 - Typical power dissipation and efficiency vs output power

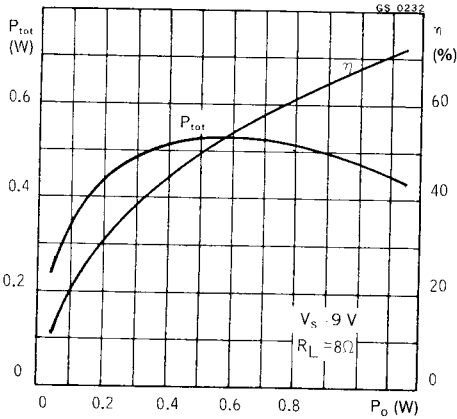

Fig. 11 - Typical power dissipation and efficiency vs output power

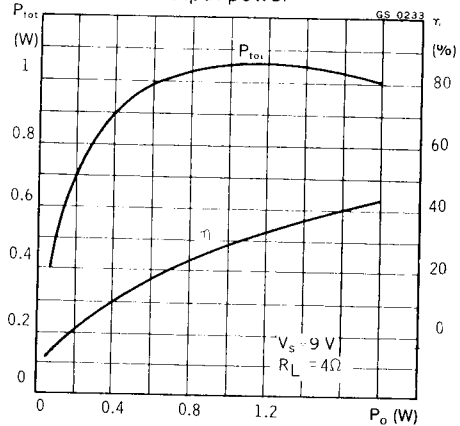

Fig. 12 - Typical power dissipation and efficiency vs output power

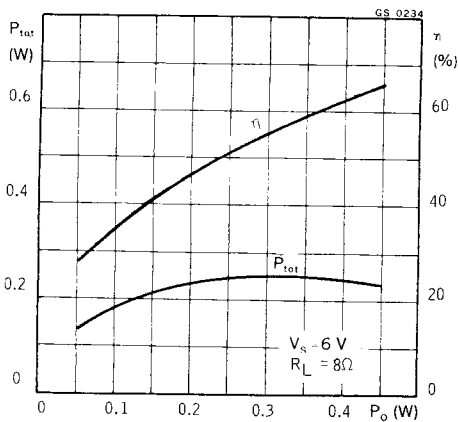
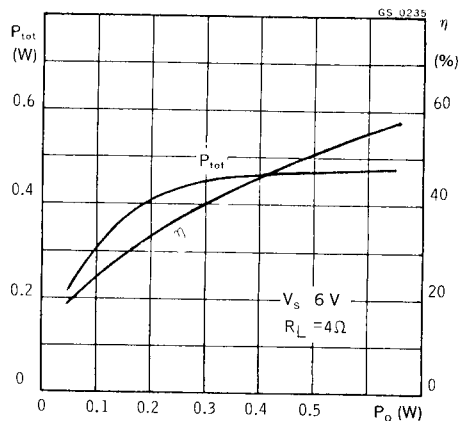

Fig. 13 - Typical power dissipation and efficiency vs output power



TAA 611A

Fig. 14 - Typical drain current vs output power

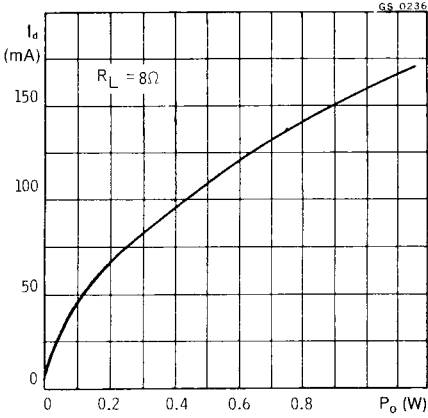

Fig. 15 - Maximum power dissipation vs load resistance

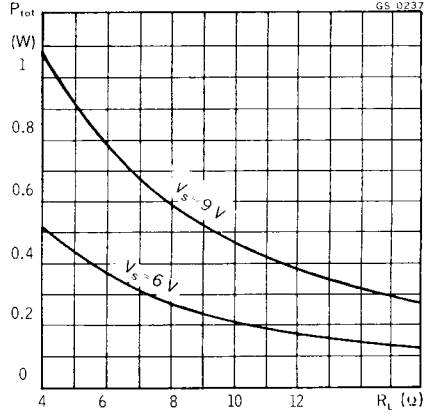

Fig. 16 - Power rating chart (TAA 611 A55)

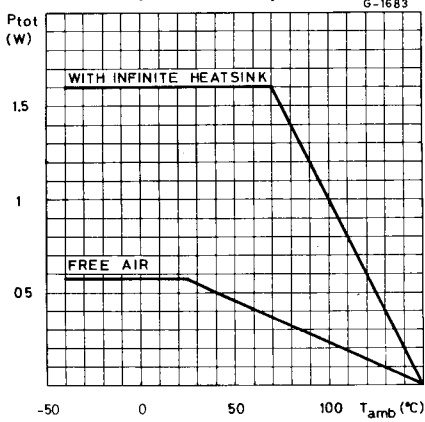
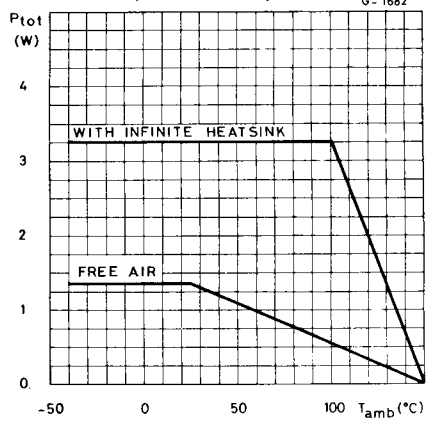

Fig. 17 - Power rating chart (TAA 611 A12)



TAA 611A

Fig. 18 - Typical quiescent drain current vs supply voltage

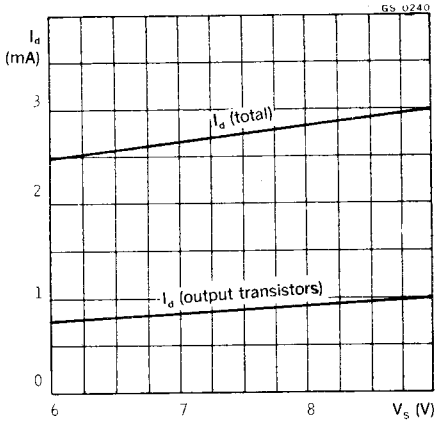

Fig. 19 - Typical quiescent drain current vs ambient temperature

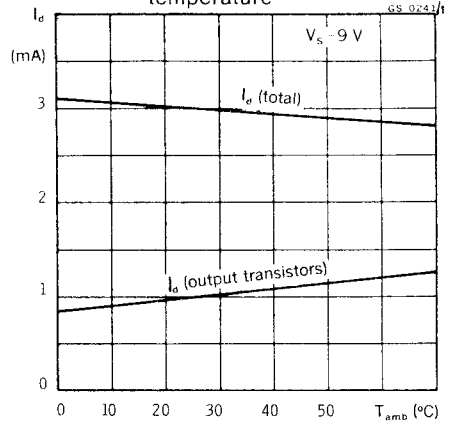
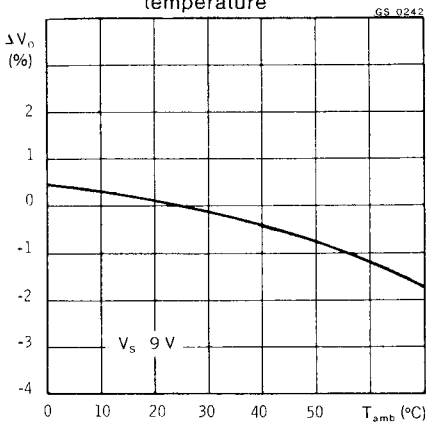

Fig. 20 - Typical quiescent output voltage vs ambient temperature



TAA 611A

TYPICAL APPLICATIONS

Fig. 21 - Audio amplifier for record-player

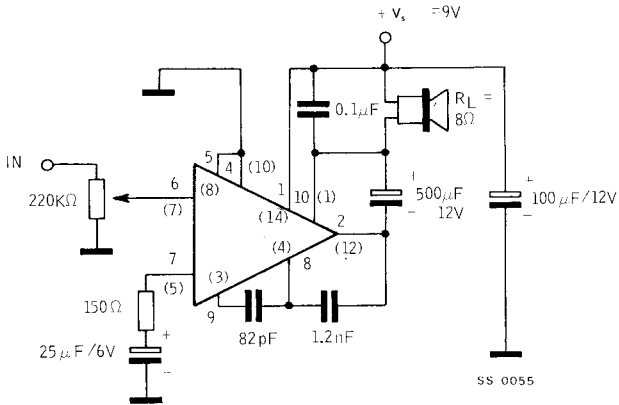
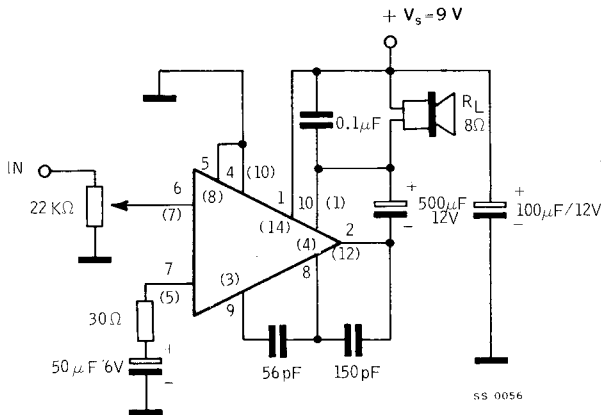

Fig. 22 - Audio amplifier for radio



The pin numbers in brackets refer to the TAA 611 A12 and those without brackets refer to the TAA 611 A55.