

**TMS27C020 262144 BY 8-BIT UV ERASABLE
TMS27PC020 262144 BY 8-BIT
PROGRAMMABLE READ-ONLY MEMORIES**

SMLS020C – NOVEMBER 1990 – REVISED SEPTEMBER 1997

- D Organization . . . 262144 by 8 Bits
- D Single 5-V Power Supply
- D Operationally Compatible With Existing Megabit EPROMs
- D Industry Standard 32-Pin Dual-In-line Package and 32-Lead Plastic Leaded Chip Carrier
- D All Inputs/Outputs Fully TTL Compatible
- D $\pm 10\%$ V_{CC} Tolerance
- D Max Access/Min Cycle Time
 $V_{CC} \pm 10\%$
 - '27C/PC020-10 100 ns
 - '27C/PC020-12 120 ns
 - '27C/PC020-15 150 ns
 - '27C/PC020-20 200 ns
 - '27C/PC020-25 250 ns
- D 8-Bit Output For Use in Microprocessor-Based Systems
- D Very High-Speed SNAP! Pulse Programming
- D Power Saving CMOS Technology
- D 3-State Output Buffers
- D 400 mV Minimum DC Noise Immunity With Standard TTL Loads
- D Latchup Immunity of 250 mA on All Input and Output Pins
- D No Pullup Resistors Required
- D Low Power Dissipation ($V_{CC} = 5.5$ V)
 - Active . . . 165 mW Worst Case
 - Standby . . . 0.55 mW Worst Case (CMOS-Input Levels)
- D Temperature Range Options

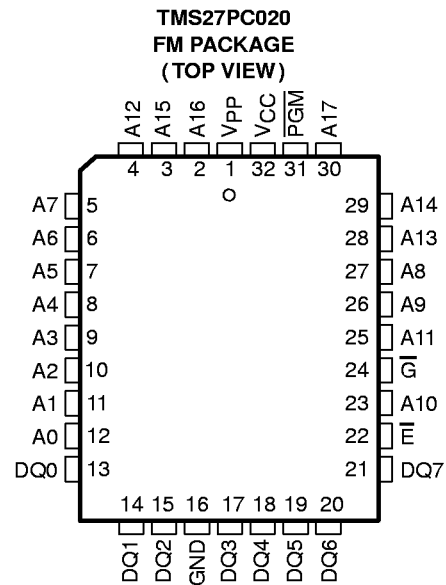
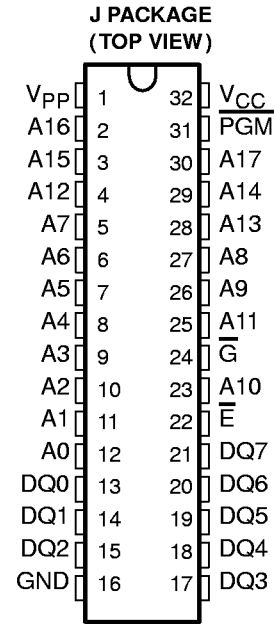

description

The TMS27C020 series are 262144 by 8-bit (2097152-bit), ultraviolet (UV) light erasable, electrically programmable read-only memories (EPROMs).

The TMS27PC020 series are one-time programmable (OTP) electrically programmable read-only memories (PROMs).

PIN NOMENCLATURE	
A0–A17	Address Inputs
DQ0–DQ7	Inputs (programming)/Outputs
\bar{E}	Chip Enable
\bar{G}	Output Enable
GND	Ground
PGM	Program
V_{CC}	5-V Power Supply
V_{PP}	13-V Power Supply †

† Only in program mode



Please be aware that an important notice concerning availability, standard warranty, and use in critical applications of Texas Instruments semiconductor products and disclaimers thereto appears at the end of this data sheet.

PRODUCTION DATA information is current as of publication date. Products conform to specifications per the terms of Texas Instruments standard warranty. Production processing does not necessarily include testing of all parameters.



POST OFFICE BOX 1443 • HOUSTON, TEXAS 77251-1443

Copyright © 1997, Texas Instruments Incorporated

**TMS27C020 262144 BY 8-BIT UV ERASABLE
TMS27PC020 262144 BY 8-BIT
PROGRAMMABLE READ-ONLY MEMORIES**

SMLS020C – NOVEMBER 1990 – REVISED SEPTEMBER 1997

description (continued)

These devices are fabricated using power-saving CMOS technology for high speed and simple interface with MOS and bipolar circuits. All inputs (including program data inputs) can be driven by Series 74 TTL circuits without the use of external pullup resistors. Each output can drive one Series 74 TTL circuit without external resistors.

The TMS27C020 EPROM is offered in a dual-in-line ceramic package (J suffix) designed for insertion in mounting hole rows on 15,2-mm (600-mil) centers. The TMS27C020 is also offered with two choices of temperature ranges of 0° to 70°C (JL suffix) and – 40°C to 85°C (JE suffix). See Table 1.

The TMS27PC020 is offered in a 32-lead plastic leaded chip carrier using 1,25 mm (50 mil) lead spacing (FM suffix). The TMS27PC020 is offered with two choices of temperature ranges of 0°C to 70°C (FML suffix) and – 40°C to 85°C (FME suffix). See Table 1.

Table 1. Temperature Range Suffixes

FUNCTION	SUFFIX FOR OPERATING TEMPERATURE RANGES	
	0°C TO 70°C	–40 °C TO 85°C
TMS27C040-XXX	JL	JE
TMS27PC040-XXX	FML	FME

These EPROMs operate from a single 5-V supply (in the read mode), they are ideal for use in microprocessor-based systems. One other (13 V) supply is needed for programming. All programming signals are TTL level. For programming outside the system, existing EPROM programmers can be used.

operation

The seven modes of operation for the TMS27C020 and TMS27PC020 are listed in Table 2. The read mode requires a single 5-V supply. All inputs are TTL level except for V_{PP} during programming (13 V), and V_H (12 V) on A9 for the signature mode.

Table 2. Operation Modes

FUNCTION	MODE†							
	READ	OUTPUT DISABLE	STANDBY	PROGRAMMING	VERIFY	PROGRAM INHIBIT	SIGNATURE MODE	
E	V _{IL}	V _{IL}	V _{IH}	V _{IL}	V _{IL}	V _{IH}	V _{IL}	
\overline{G}	V _{IL}	V _{IH}	X	V _{IH}	V _{IL}	X	V _{IL}	
\overline{PGM}	X	X	X	V _{IL}	V _{IH}	X	X	
V _{PP}	X	V _{CC}	V _{CC}	V _{PP}	V _{PP}	V _{PP}	V _{CC}	
V _{CC}	V _{CC}	V _{CC}	V _{CC}	V _{CC}	V _{CC}	V _{CC}	V _{CC}	
A9	X	X	X	X	X	X	V _H ‡ V _H ‡	
A0	X	X	X	X	X	X	V _{IL} V _{IH}	
DQ0–DQ7	Data Out	Hi-Z	Hi-Z	Data In	Data Out	Hi-Z	CODE	
							MFG	DEVICE
							97	32

† X can be V_{IL} or V_{IH}
‡ V_H = 12 V ± 0.5 V



read/output disable

When the outputs of two or more TMS27C020s or TMS27PC020s are connected in parallel on the same bus, the output of any particular device in the circuit can be read with no interference from competing outputs of the other devices. To read the output of a single device, a low level signal is applied to the \overline{E} and \overline{G} pins. All other devices in the circuit should have their outputs disabled by applying a high level signal to one of these pins.

latchup immunity

Latchup immunity on the TMS27C020 and TMS27PC020 is a minimum of 250 mA on all inputs and outputs. This feature provides latchup immunity beyond any potential transients at the P.C. board level when the EPROM is interfaced to industry standard TTL or MOS logic devices. The input/output layout approach controls latchup without compromising performance or packing density.

power down

Active I_{CC} supply current can be reduced from 30 mA to 500 μ A by applying a high TTL input on \overline{E} and to 100 μ A by applying a high CMOS input on \overline{E} . In this mode all outputs are in the high-impedance state.

erasure

Before programming, the TMS27C020 is erased by exposing the chip through the transparent lid to a high intensity ultraviolet light (wavelength 2537 Å). The recommended minimum exposure dose (UV intensity \times exposure time) is 15-W.s/cm². A typical 12-mW/cm², filterless UV lamp erases the device in 21 minutes. The lamp should be located about 2.5 cm above the chip during erasure. After erasure, all bits are in the high state. It should be noted that normal ambient light contains the correct wavelength for erasure. Therefore, when using the TMS27C020, the window should be covered with an opaque label. After erasure (all bits in logic high state), logic lows are programmed into the desired locations. A programmed low can be erased only by ultraviolet light.

SNAP! Pulse programming

The TMS27C020 and TMS27PC020 are programmed using the TI SNAP! Pulse programming algorithm, illustrated by the flowchart in Figure 1, which programs in a nominal time of twenty-six seconds. Actual programming time varies as a function of the programmer used.

The SNAP! Pulse programming algorithm uses an initial pulse of 100 microseconds (μ s) followed by a byte verification to determine when the addressed byte has been successfully programmed. Up to ten 100- μ s pulses per byte are provided before a failure is recognized.

The programming mode is achieved when V_{PP} equals 13 V, $V_{CC} = 6.5$ V, $\overline{E} = V_{IL}$, $\overline{G} = V_{IH}$. Data is presented in parallel (eight bits) on pins DQ0 through DQ7. Once addresses and data are stable, \overline{PGM} is pulsed low.

More than one device can be programmed when the devices are connected in parallel. Locations can be programmed in any order. When the SNAP! Pulse programming routine is complete, all bits are verified with $V_{CC} = V_{PP} = 5$ V \pm 10%.

program inhibit

Programming can be inhibited by maintaining a high level input on the \overline{E} or \overline{PGM} pins.

program verify

Programmed bits can be verified with V_{PP} equals 13 V when $\overline{G} = V_{IL}$, $\overline{E} = V_{IL}$, and $\overline{PGM} = V_{IH}$.

signature mode

The signature mode provides access to a binary code identifying the manufacturer and type. This mode is activated when A9 (pin 26) is forced to 12 V. Two identifier bytes are accessed by toggling A0. All other addresses must be held low. The signature code for the TMS27C020 is 9732. A0 low selects the manufacturer's code 97 (Hex), and A0 high selects the device code 32 (Hex), as shown in Table 3.

**TMS27C020 262144 BY 8-BIT UV ERASABLE
TMS27PC020 262144 BY 8-BIT
PROGRAMMABLE READ-ONLY MEMORIES**

SMLS020C – NOVEMBER 1990 – REVISED SEPTEMBER 1997

signature mode (continued)

Table 3. Signature Mode

IDENTIFIERT	PINS									
	A0	DQ7	DQ6	DQ5	DQ4	DQ3	DQ2	DQ1	DQ0	HEX
MANUFACTURER CODE	V _{IL}	1	0	0	1	0	1	1	1	97
DEVICE CODE	V _{IH}	0	0	1	1	0	0	1	0	32

† $\bar{E} = \bar{G} = V_{IL}$, A1–A8 = V_{IL}, A9 = V_H, A10–A17 = V_{IL}, V_{PP} = V_{CC}.



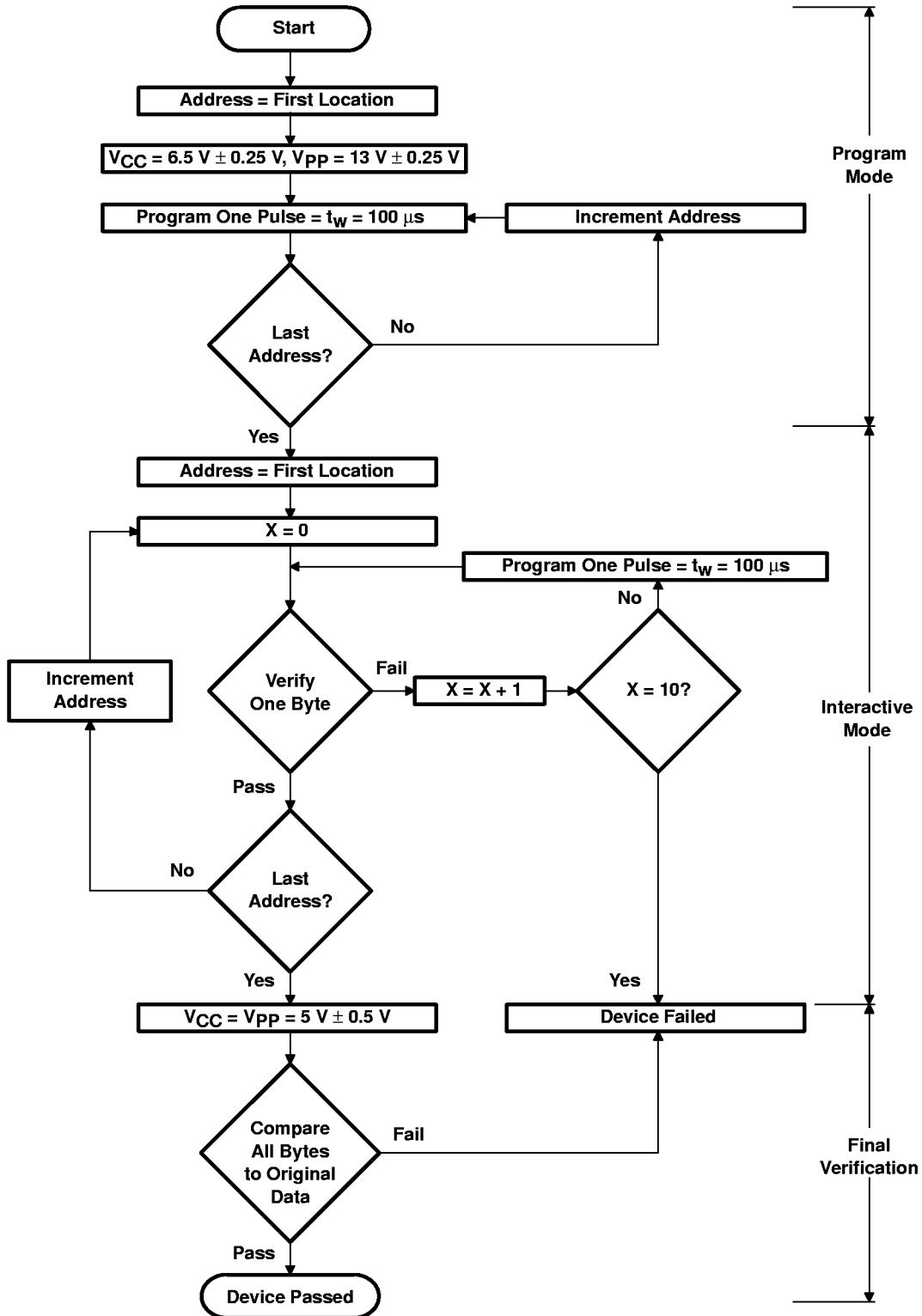
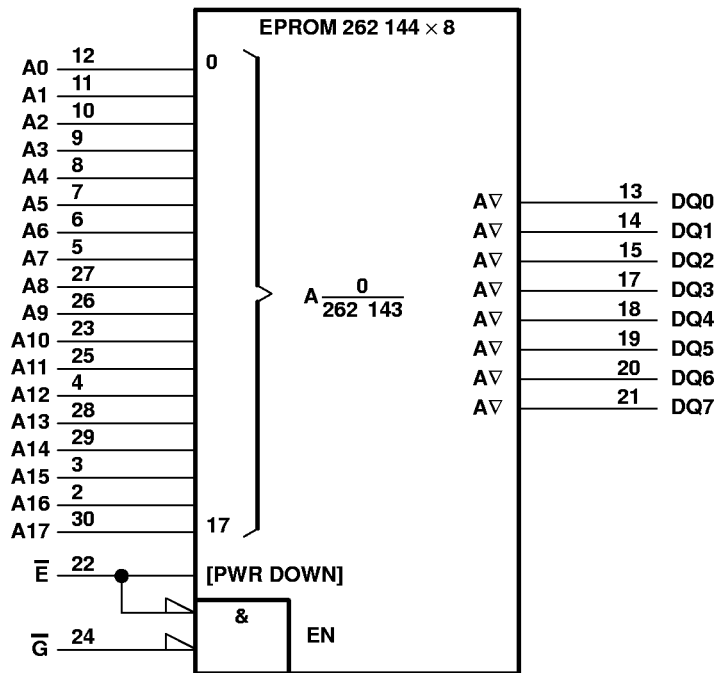

Figure 1. SNAP! Pulse Programming Flowchart

**TMS27C020 262144 BY 8-BIT UV ERASABLE
TMS27PC020 262144 BY 8-BIT
PROGRAMMABLE READ-ONLY MEMORIES**

SMLS020C – NOVEMBER 1990 – REVISED SEPTEMBER 1997

logic symbol†



† This symbol is in accordance with ANSI/IEEE Std 91-1984 and IEC Publication 617-12. Pin numbers are for the J package.

**TMS27C020 262144 BY 8-BIT UV ERASABLE
TMS27PC020 262144 BY 8-BIT
PROGRAMMABLE READ-ONLY MEMORIES**

SMLS020C – NOVEMBER 1990 – REVISED SEPTEMBER 1997

absolute maximum ratings over operating free-air temperature range (unless otherwise noted)‡

Supply voltage range, V_{CC} (see Note 1) :	–0.6 V to 7 V
Supply voltage range, V_{PP} :	–0.6 V to 14 V
Input voltage range (see Note 1), All inputs except A9 :	–0.6 V to $V_{CC} + 1$ V
A9 :	–0.6 V to 13.5 V
Output voltage range, with respect to V_{SS} (see Note 1) :	–0.6 V to $V_{CC} + 1$ V
Operating free-air temperature range ('27C020-__JL, '27PC020-__FML) :	0°C to 70°C
Operating free-air temperature range ('27C020-__JE, '27PC020-__FME) :	–40°C to 85°C
Storage temperature range, T_{stg} :	–65°C to 150°C

‡ Stresses beyond those listed under “absolute maximum ratings” may cause permanent damage to the device. These are stress ratings only, and functional operation of the device at these or any other conditions beyond those indicated under “recommended operating conditions” is not implied. Exposure to absolute-maximum-rated conditions for extended periods may affect device reliability.

NOTE 1: All voltage values are with respect to GND.

recommended operating conditions

		MIN	NOM	MAX	UNIT	
V_{CC}	Supply voltage	Read mode (see Note 2)	4.5	5	5.5	V
		SNAP! Pulse programming algorithm	6.25	6.5	6.75	V
V_{PP}	Supply voltage	Read mode	$V_{CC}-0.6$	V_{CC}	$V_{CC}+0.6$	V
		SNAP! Pulse programming algorithm	12.75	13	13.25	V
V_{IH}	High-level dc input voltage	TTL	2		$V_{CC}+0.5$	V
		CMOS	$V_{CC}-0.2$		$V_{CC}+0.5$	V
V_{IL}	Low-level dc input voltage	TTL	–0.5		0.8	V
		CMOS	–0.5		GND+0.2	V
T_A	Operating free-air temperature			0	70	°C
T_A	Operating free-air temperature			–40	85	°C

NOTE 2: V_{CC} must be applied before or at the same time as V_{PP} and removed after or at the same time as V_{PP} . The device must not be inserted into or removed from the board when V_{PP} or V_{CC} is applied.

electrical characteristics over full ranges of operating conditions

PARAMETER		TEST CONDITIONS	MIN	MAX	UNIT
V_{OH}	High-level dc output voltage	$I_{OH} = -20 \mu A$	$V_{CC} - 0.2$		V
		$I_{OH} = -2 \text{ mA}$	2.4		
V_{OL}	Low-level dc output voltage	$I_{OL} = 2.1 \text{ mA}$		0.4	V
		$I_{OL} = 20 \mu A$		0.1	
I_I	Input current (leakage)	$V_I = 0 \text{ V to } 5.5 \text{ V}$		± 1	μA
I_O	Output current (leakage)	$V_O = 0 \text{ V to } V_{CC}$		± 1	μA
I_{PP1}	V_{PP} supply current	$V_{PP} = V_{CC} = 5.5 \text{ V}$		10	μA
I_{PP2}	V_{PP} supply current (during program pulse)	$V_{PP} = 13 \text{ V}$		50	mA
I_{CC1}	V_{CC} supply current (standby)	TTL-input level	$V_{CC} = 5.5 \text{ V}, \dots \bar{E} = V_{IH}$	500	μA
		CMOS-input level	$V_{CC} = 5.5 \text{ V}, \bar{E} = V_{CC} \pm 0.2 \text{ V}$	100	
I_{CC2}	V_{CC} supply current (active)	$V_{CC} = 5.5 \text{ V}, \bar{E} = V_{IL}$ $t_{cycle} = \text{minimum cycle time, outputs open}^\dagger$		30	mA

† Minimum cycle time = maximum access time.



**TMS27C020 262144 BY 8-BIT UV ERASABLE
TMS27PC020 262144 BY 8-BIT
PROGRAMMABLE READ-ONLY MEMORIES**

SMLS020C – NOVEMBER 1990 – REVISED SEPTEMBER 1997

capacitance over recommended ranges of supply voltage and operating free-air temperature, $f = 1 \text{ MHz}$ †

PARAMETER		TEST CONDITIONS	MIN	NOM‡	MAX	UNIT
C_I	Input capacitance	$V_I = 0 \text{ V}, f = 1 \text{ MHz}$		4	8	pF
C_O	Output capacitance	$V_O = 0 \text{ V}, f = 1 \text{ MHz}$		6	10	pF

† Capacitance measurements are made on sample basis only.

‡ All typical values are at $T_A = 25^\circ\text{C}$ and nominal voltages.

switching characteristics over full ranges of recommended operating conditions (see Notes 3 and 4)

PARAMETER	TEST CONDITIONS	'27C020-10 '27PC020-10		'27C020-12 '27PC020-12		'27C020-15 '27PC020-15		27C020-20 27PC020-20		'27C020-25 '27PC020-25		UNIT
		MIN	MAX	MIN	MAX	MIN	MAX	MIN	MAX	MIN	MAX	
$t_{a(A)}$	Access time from address	100		120		150		200		250		ns
$t_{a(E)}$	Access time from chip enable	100		120		150		200		250		ns
$t_{en(G)}$	Output enable time from \overline{G}	55		55		75		75		100		ns
t_{dis}	Output disable time from \overline{G} or \overline{E} , whichever occurs first†	0	50	0	50	0	60	0	60	0	80	ns
$t_{v(A)}$	Output data valid time after change of address, \overline{E} , or \overline{G} , whichever occurs first§	0		0		0		0		0		ns

§ Value calculated from 0.5-V delta to measured output level. This parameter is sampled and not 100% tested.

NOTES: 3. For all switching characteristics, the input pulse levels are 0.4 V to 2.4 V. Timing measurements are made at 2 V for logic high and 0.8 V for logic low. (See Figure 2).

4. Common test conditions apply for t_{dis} except during programming.



**TMS27C020 262144 BY 8-BIT UV ERASABLE
TMS27PC020 262144 BY 8-BIT
PROGRAMMABLE READ-ONLY MEMORIES**
SMLS020C – NOVEMBER 1990 – REVISED SEPTEMBER 1997

switching characteristics for programming: $V_{CC} = 6.5\text{ V}$ and $V_{PP} = 13\text{ V}$ (SNAP! Pulse), $T_A = 25^\circ\text{C}$ (see Note 3)

PARAMETER		MIN	MAX	UNIT
$t_{dis(G)}$	Output disable time from \overline{G}	0	100	ns
$t_{en(G)}$	Output enable time from \overline{G}		150	ns

NOTE 3: For all switching characteristics the input pulse levels are 0.4 V to 2.4 V. Timing measurements are made at 2 V for logic high and 0.8 V for logic low (See Figure 2).

timing requirements for programming

		MIN	TYP	MAX	UNIT		
$t_w(\text{PGM})$	Pulse duration, program	SNAP! Pulse programming algorithm		95	100	105	μs
$t_{su(A)}$	Setup time, address	2				μs	
$t_{su(E)}$	Setup time, \overline{E}	2				μs	
$t_{su(G)}$	Setup time, \overline{G}	2				μs	
$t_{su(D)}$	Setup time, data	2				μs	
$t_{su(VPP)}$	Setup time, V_{PP}	2				μs	
$t_{su(VCC)}$	Setup time, V_{CC}	2				μs	
$t_h(A)$	Hold time, address	0				μs	
$t_h(D)$	Hold time, data	2				μs	



PARAMETER MEASUREMENT INFORMATION

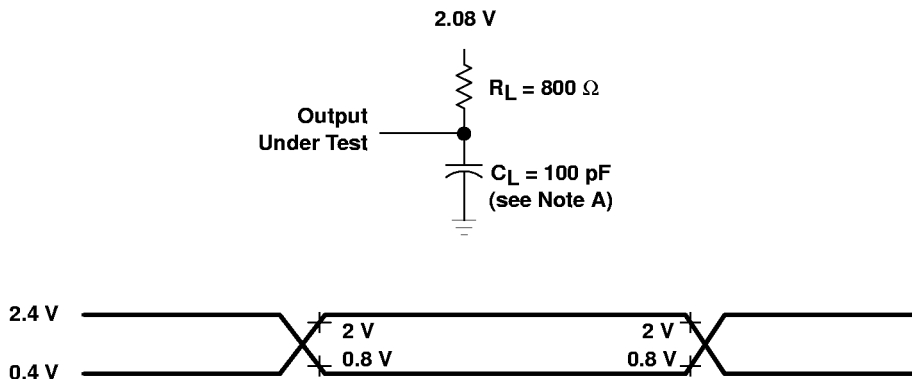

- NOTES: A. C_L includes probe and fixture capacitance.
 B. The ac testing inputs are driven at 2.4 V for logic high and 0.4 V for logic low. Timing measurements are made at 2 V for logic high and 0.8 V for logic low for both inputs and outputs.

Figure 2. The ac Testing Output Load Circuit and Waveform

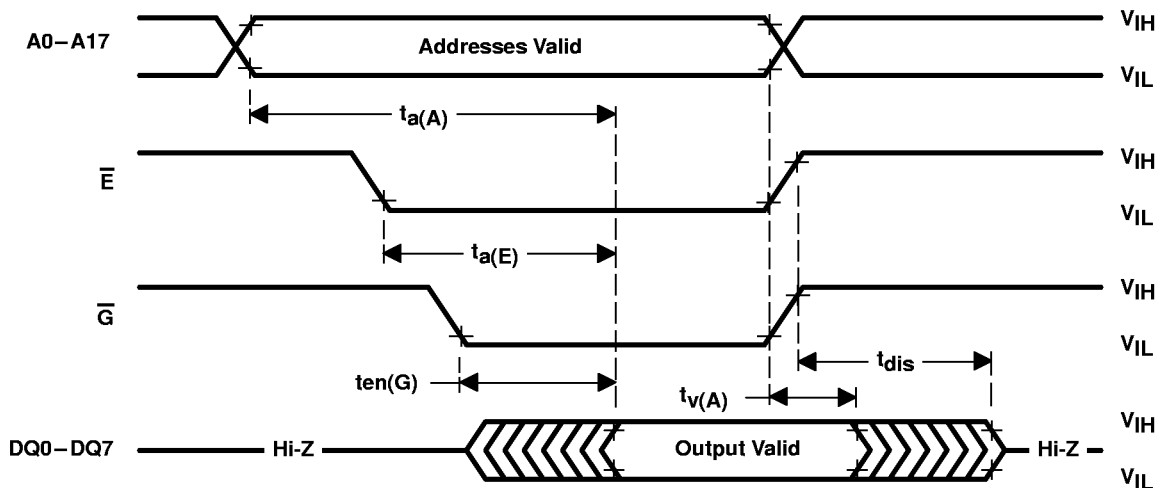
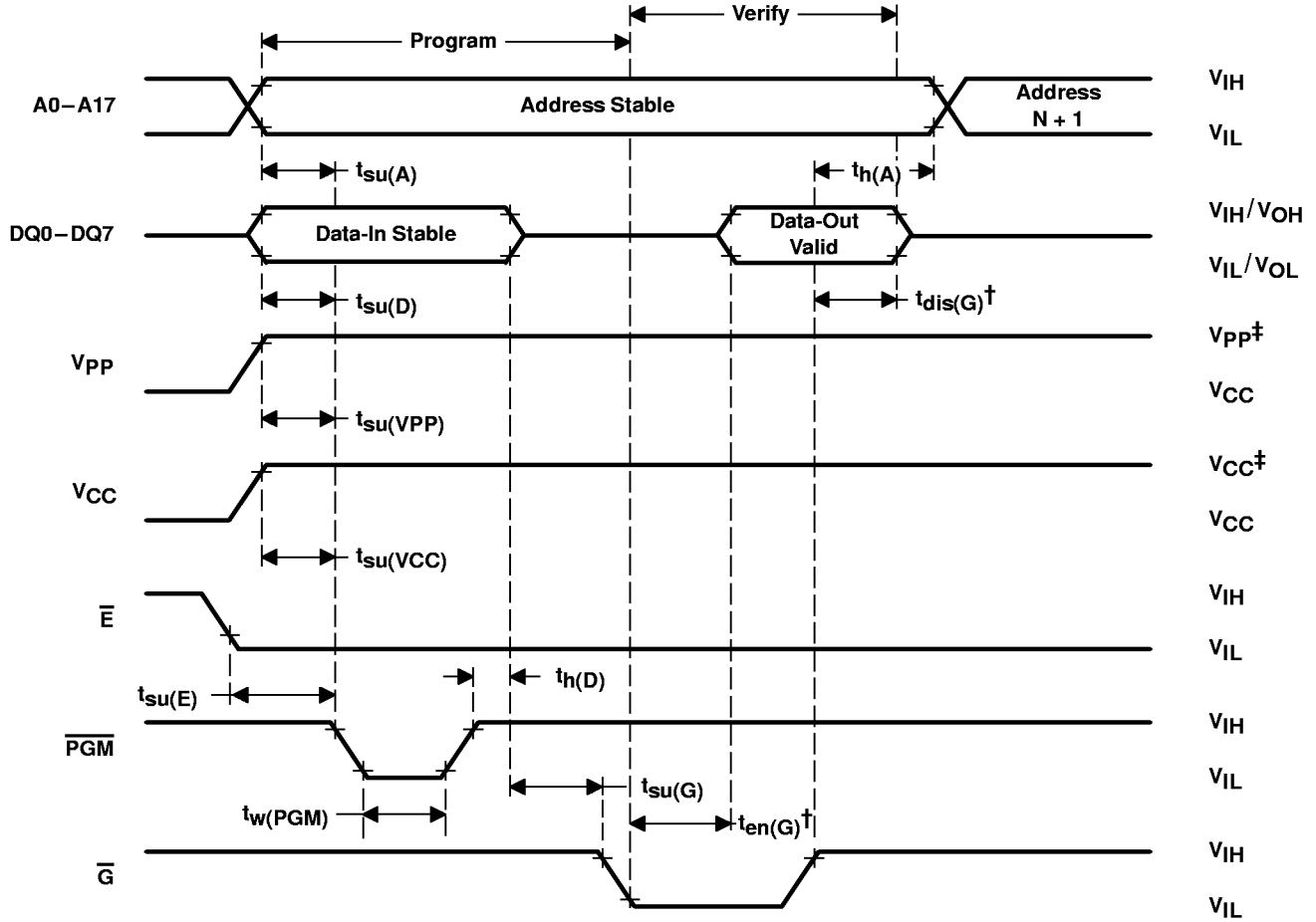

Figure 3. Read-Cycle Timing

PARAMETER MEASUREMENT INFORMATION



† $t_{dis(G)}$ and $t_{en(G)}$ are characteristics of the device but must be accommodated by the programmer.
‡ 13-V V_{PP} and 6.5-V V_{CC} for SNAP! Pulse programming.

Figure 4. Program-Cycle Timing (SNAP! Pulse Programming)

**TMS27C020 262144 BY 8-BIT UV ERASABLE
TMS27PC020 262144 BY 8-BIT
PROGRAMMABLE READ-ONLY MEMORIES**

SMLS020C – NOVEMBER 1990 – REVISED SEPTEMBER 1997

FM (R-PQCC-J32)

PLASTIC J-LEADED CHIP CARRIER

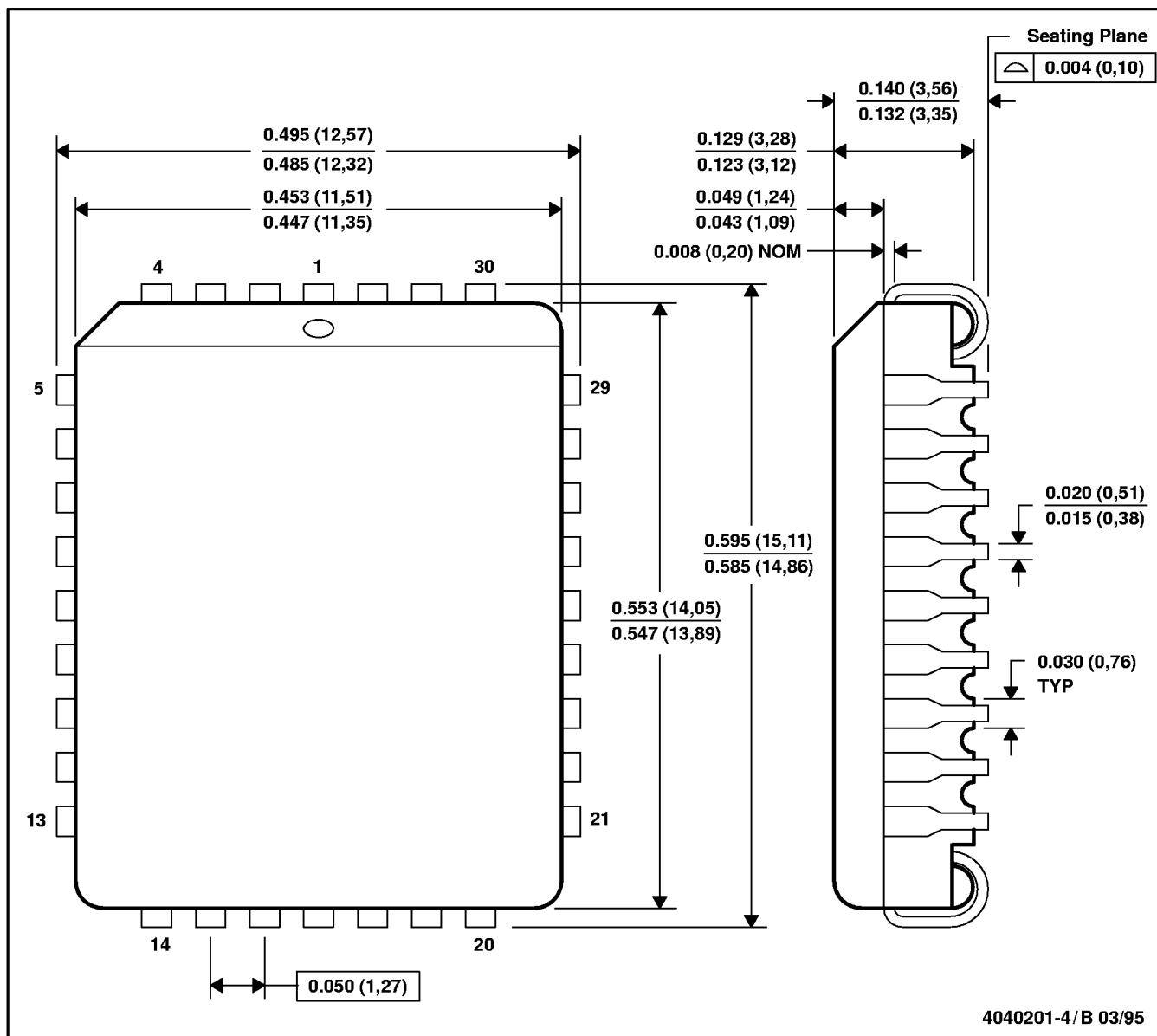

- NOTES: A. All linear dimensions are in inches (millimeters).
 B. This drawing is subject to change without notice.
 C. Falls within JEDEC MS-016



**TMS27C020 262144 BY 8-BIT UV ERASABLE
TMS27PC020 262144 BY 8-BIT
PROGRAMMABLE READ-ONLY MEMORIES**

SMLS020C – NOVEMBER 1990 – REVISED SEPTEMBER 1997

J (R-CDIP-T)**

CERAMIC SIDE-BRAZE DUAL-IN-LINE PACKAGE

24 PIN SHOWN

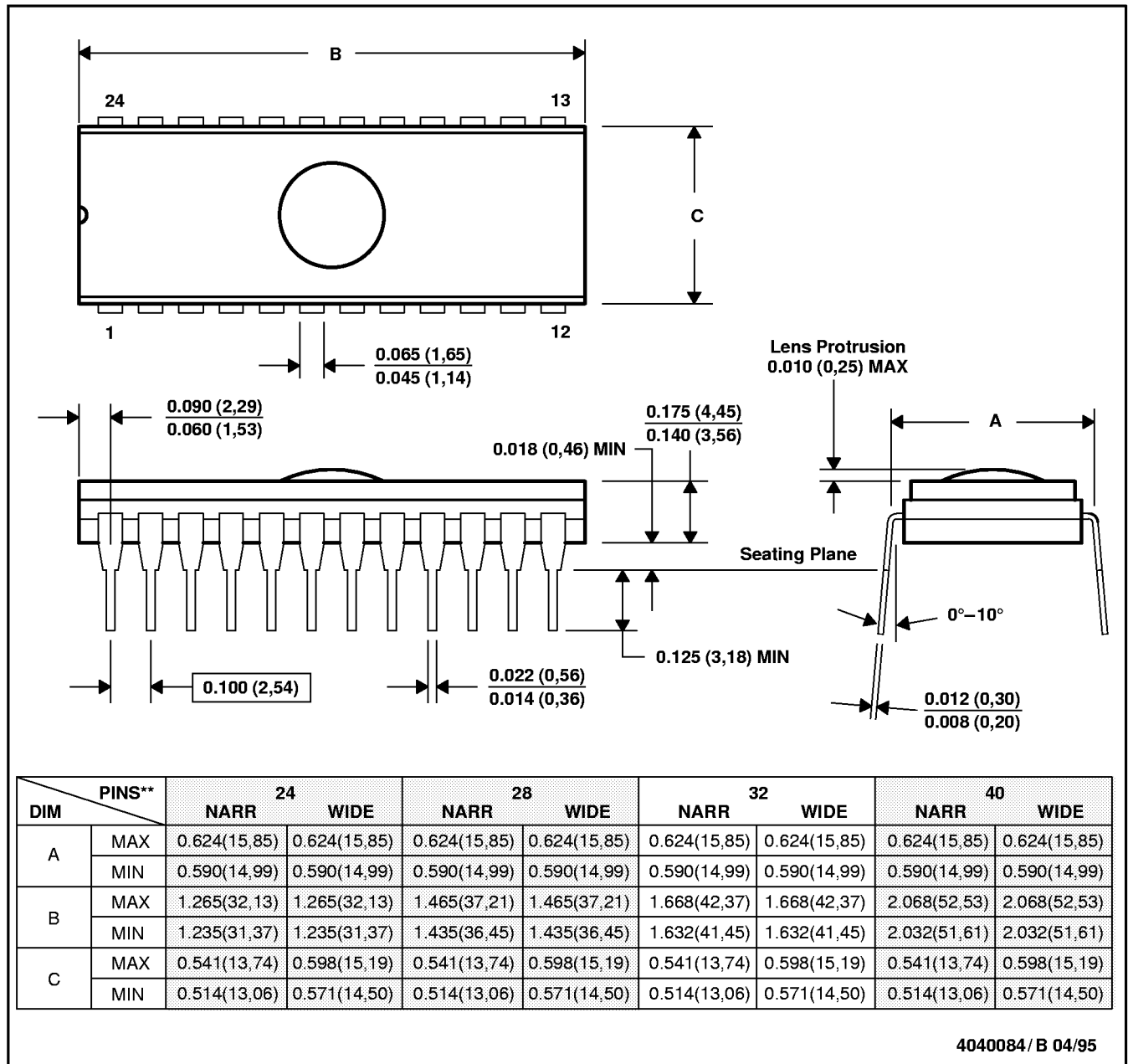

- NOTES: A. All linear dimensions are in inches (millimeters).
 B. This drawing is subject to change without notice.
 C. This package can be hermetically sealed with a ceramic lid using glass frit.
 D. Index point is provided on cap for terminal identification only on press ceramic glass frit seal only.

**TMS27C020 262144 BY 8-BIT UV ERASABLE
TMS27PC020 262144 BY 8-BIT
PROGRAMMABLE READ-ONLY MEMORIES**

SMLS020C – NOVEMBER 1990 – REVISED SEPTEMBER 1997



IMPORTANT NOTICE

Texas Instruments (TI) reserves the right to make changes to its products or to discontinue any semiconductor product or service without notice, and advises its customers to obtain the latest version of relevant information to verify, before placing orders, that the information being relied on is current.

TI warrants performance of its semiconductor products and related software to the specifications applicable at the time of sale in accordance with TI's standard warranty. Testing and other quality control techniques are utilized to the extent TI deems necessary to support this warranty. Specific testing of all parameters of each device is not necessarily performed, except those mandated by government requirements.

Certain applications using semiconductor products may involve potential risks of death, personal injury, or severe property or environmental damage ("Critical Applications").

TI SEMICONDUCTOR PRODUCTS ARE NOT DESIGNED, INTENDED, AUTHORIZED, OR WARRANTED TO BE SUITABLE FOR USE IN LIFE-SUPPORT APPLICATIONS, DEVICES OR SYSTEMS OR OTHER CRITICAL APPLICATIONS.

Inclusion of TI products in such applications is understood to be fully at the risk of the customer. Use of TI products in such applications requires the written approval of an appropriate TI officer. Questions concerning potential risk applications should be directed to TI through a local SC sales office.

In order to minimize risks associated with the customer's applications, adequate design and operating safeguards should be provided by the customer to minimize inherent or procedural hazards.

TI assumes no liability for applications assistance, customer product design, software performance, or infringement of patents or services described herein. Nor does TI warrant or represent that any license, either express or implied, is granted under any patent right, copyright, mask work right, or other intellectual property right of TI covering or relating to any combination, machine, or process in which such semiconductor products or services might be or are used.