

FM STEREO MULTIPLEX DECODER, PHASE LOCKED LOOP

μ A758

DESCRIPTION

The μ A758 is a monolithic phase-locked loop FM stereo multiplex decoder. The device decodes an FM stereo multiplex signal into right and left audio channels while inherently suppressing SCA information when it is contained in the composite input signal. The device includes automatic mono-stereo mode switching and drive for an external lamp to indicate stereo mode operation.

The μ A758 operates over a large voltage range and requires a minimum number of external components. A simple setting of an external potentiometer adjusts the oscillator frequency. No coils are required.

FEATURES

- 45dB channel separation
- Automatic stereo/mono switching
- 70dB SCA rejection
- 10V to 16V supply range
- High impedance input—low impedance output

PIN CONFIGURATION

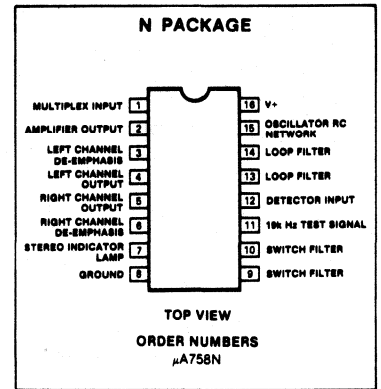

ABSOLUTE MAXIMUM RATINGS

PARAMETER	RATING	UNIT
Supply voltage	+18	V
Supply voltage (\leq 15 seconds)	+22	V
Voltage at lamp driver terminal (Lamp OFF)	+22	V
Internal power dissipation	730	mW
Operating temperature range	-40 to +85	$^{\circ}$ C
Storage temperature range	-55 to +125	$^{\circ}$ C
Lead temperature (60sec)	300	$^{\circ}$ C

BLOCK DIAGRAM

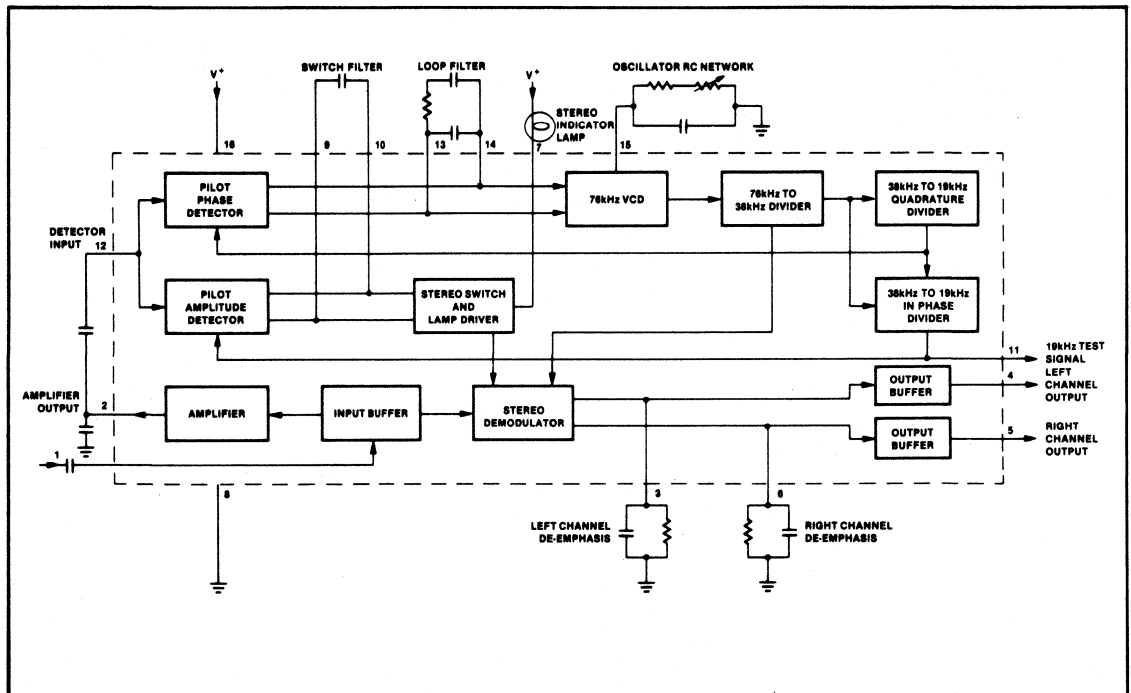

FM STEREO MULTIPLEX DECODER, PHASE LOCKED LOOP

μA758

EQUIVALENT SCHEMATIC

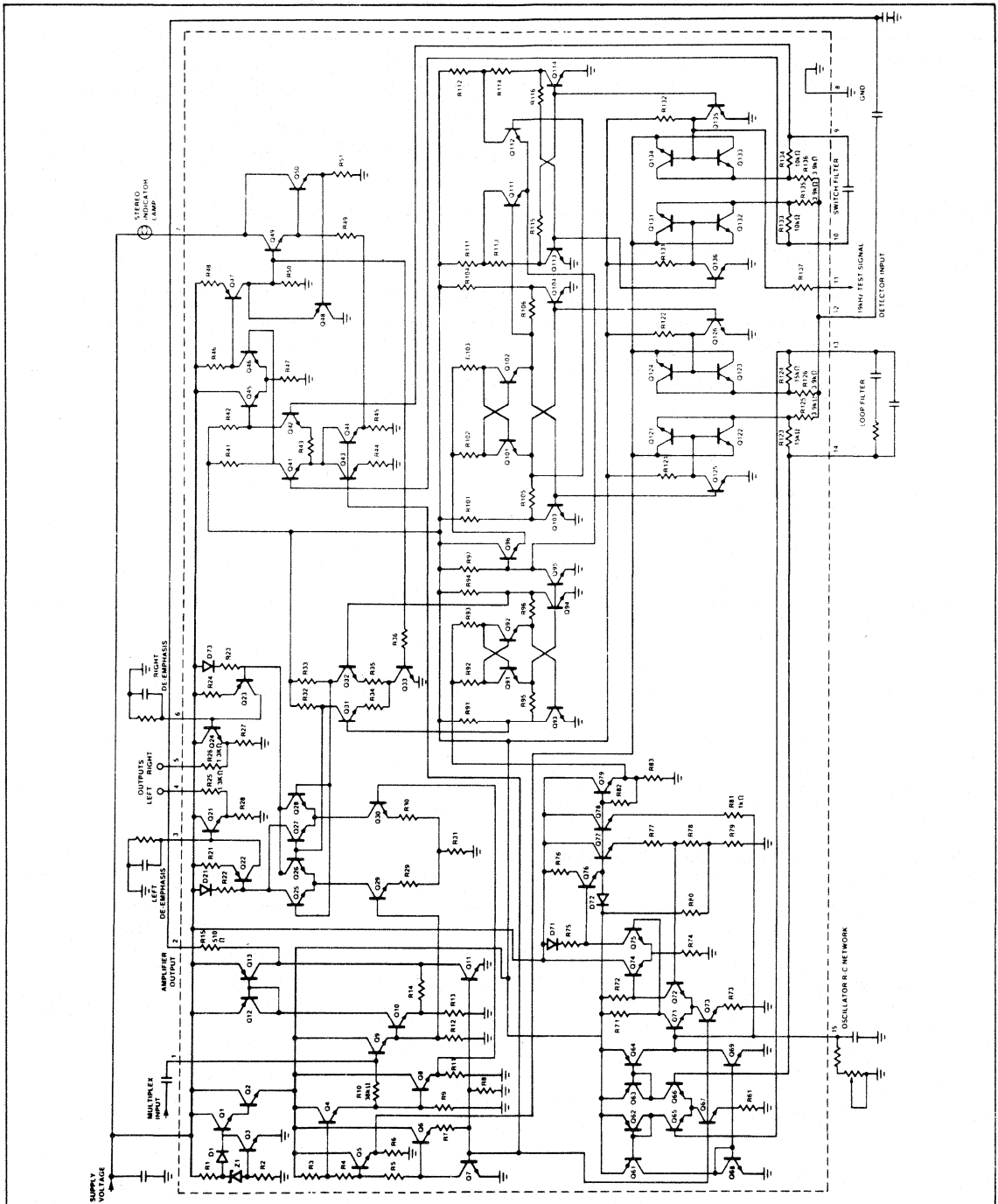

FM STEREO MULTIPLEX DECODER, PHASE LOCKED LOOP

 μ A758

DC ELECTRICAL CHARACTERISTICS

$T_A = 25^\circ\text{C}$, $V_+ = +12\text{V}$, 19kHz pilot level = 30mVRMS, multiplex signal (L = R, pilot OFF) = 300mVRMS, modulation frequency = 400Hz or 1Hz, test circuit 1, unless otherwise specified.

PARAMETER	TEST CONDITIONS	μ A758			UNIT
		Min	Typ	Max	
I_{CC}	Supply current		31	38	mA
I_L	Maximum available lamp current	75	150		mA
V_7	Voltage at lamp driver terminal		1.3	1.8	V
r_i	Input resistance	20	35		k Ω
r_o	Output resistance	0.9	1.3	2.0	k Ω

AC ELECTRICAL CHARACTERISTICS

PARAMETER	TEST CONDITIONS	μ A758			UNIT	
		Min	Typ	Max		
$\Delta(V_4 \& V_5)$	DC voltage shift at either output terminal		30	150	mV	
P_{SRR}	Power supply ripple rejection	200Hz, 200mVRMS	35		dB	
SEP	Channel separation	100Hz	40		dB	
		400Hz	45		dB	
		10kHz	45		dB	
BAL.	Channel balance		0.3	1.5	dB	
A_v	Voltage gain	1kHz	0.5	0.9	V/V	
	Pilot input level	Lamp turn-on	18	25	mVRMS	
		Lamp turn-off	2.0	7.0	mVRMS	
	Pilot input level hysteresis	Lamp turn-off to turn-on	3.0	7.0	dB	
	Capture range		2.0	4.0	%	
T.H.D.	Total harmonic distortion	Multiplex level = 600mVRMS pilot OFF	0.4	1.0	%	
	19kHz rejection		25	35	dB	
	38kHz rejection		25	45	dB	
	SCA rejection ¹			70	dB	
VCO	Tuning resistance ²		21.0	23.3	25.5	k Ω
VCO	Frequency drift	$0^\circ\text{C} \leq T_A \leq 25^\circ\text{C}$ $25^\circ\text{C} \leq T_A \leq 70^\circ\text{C}$		+0.1 -0.4	± 2 ± 2	%

NOTES

- Measured with a stereo composite signal consistency of 80% stereo, 10% pilot and 10% SCA as defined in the FCC Rules on Broadcasting.
- Total resistance from pin 15 to ground, in test circuit, required to set reference frequency at pin 11 to 19kHz \pm 10Hz.

TYPICAL PERFORMANCE CHARACTERISTICS

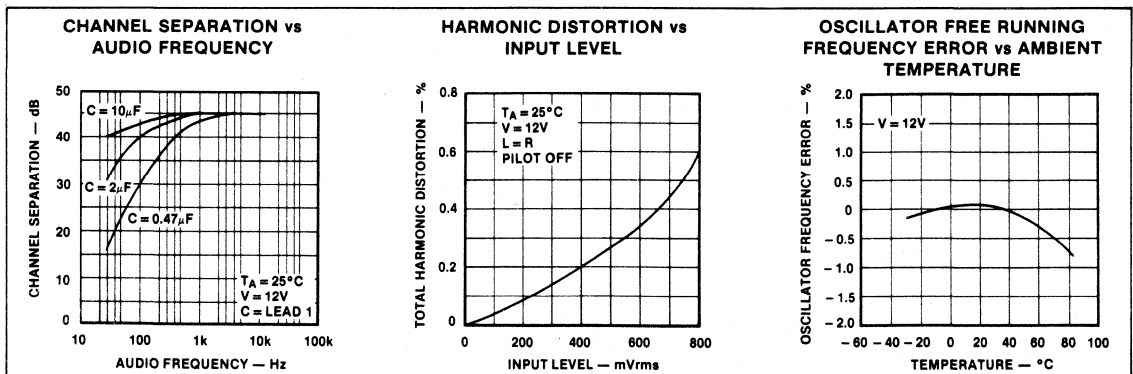

TYPICAL PERFORMANCE CHARACTERISTICS (Cont'd)

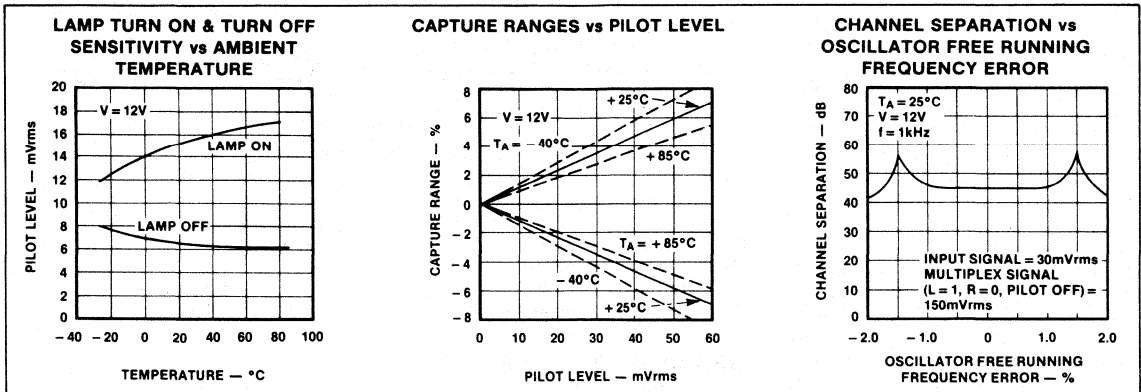

TEST CIRCUIT AND TYPICAL APPLICATION

