



Leaders in device programming, copying, simulation

E2A
E8A
E9A

/B. Schemas.



E2A, E8A, E9A CIRCUIT DESCRIPTION

CONTENTS

Clock, Micro-processor & buffers	2
Address Decoder, Internal Eprom & Scratchpad Ram	2
Port Decode & Latches	2
Chip Select	2
Address Latch	2
Variable Access Time Control	3
Data Latch	3
Interface Circuits	3
Display & Piezo Sounder	4
Keyboard	4
Intelligent Identifier	4
P.S.U. Circuit : Mains Transformer	5
: General	5
: +5v Supplies	5
: Vpp Supplies	6
: P.S.U. Monitor	6
Interface & Memory Board	7
: 1. Hex-Keypad	
: 2. Serial RS232 Input/Output	
: 3. Parallel Input/Output	
: 4. RAM	

Clock, Micro-processor & Buffers

IC1 and associated circuitry generates a 4MHz crystal controlled clock signal which is used to clock the micro-processor. The micro-processor IC2 is a Z80A. The data bus is buffered by IC6 a bi-directional buffer. The data direction is controlled by BRD. IC3,4 & 5 uni-directional buffers buffer the Address Bus and BWR, BRD signals.

Address Decoder, Internal EPROM and Scratchpad RAM.

One section of IC7 decodes the available 64K of addressing into four 16K sections:-

0000 to 3FFF	First EPROM	IC8
4000 to 7FFF	Second EPROM	IC9
8000 to BFFF	Scratchpad RAM	IC11
C000 to FFFF	Main RAM (Paged)	

Only 2K of Scratchpad RAM is fitted (Address 8000 to 87FF) and supported by Nickel Cadmium battery on PSU board.

The first three outputs of IC7 control the chip enable of EPROM and Scratchpad RAM selecting one device for a read or write operation in conjunction with BRD or BWR signals. The fourth output of IC7 generates the RAM signal which is 'paged' to expand the 16K segment to 128K (see Interface & memory section).

Port Decoder & Latches

IORQ, BRD, BRW signals are gated to produce an I/O write or an I/O read signal which enables pin 1 or 15 of IC12 the port sector decoder. IC12 decodes the I/O port address into four input sections (pin 4,5,6,7) or four output sections (pins 12,11,10,9) all active low. These sections are further decoded where necessary by IC13 (chip select decoder), IC14 (Various input ports), IC15 and IC16 (Various output ports).

Where data outputted to a port has to be stored it is held in latches (IC17,18,19,20).

Chip select decoder

IC13 selects one of the eight Copy sockets during a copy socket read. IC 32 selects the Master Socket during a master socket read.

Address Latch

IC26,27 latch the Port 00 and Port 01 data which is the socket Address LSB and MSB respectively. A common 00 Read signal or a latched Address/Data control signal enables the tri-state outputs of IC26, 27.

Variable Access Time Control

The tACC or access time of the EPROM is defined as the time taken for the EPROM to output correct data after the selected address is stable. In the 'E' Series programmers the read strobe is used to enable the Address latch (see above) and from this period of valid address a timing 'window' is generated by a monostable IC34. The period of the pulse generated by the monostable is determined by an R.C. time constant. The C content is fixed in C9 but the resistance can be selected via multiplexer IC33. One of eight resistors is selected by the ABC inputs.

It is therefore possible with software control to start off with a wide open 'window', check that the data is read correctly and progressively close the 'window' until the EPROM gives incorrect data.

The output of the monostable enable a transparent latch IC35 on the common Socket Data Bus. IC31A permits the automatic overriding of the Access Time facility when reading the master socket.

Data Latch

IC36 latches the data to be programmed into the EPROMS. This has tri-state outputs controlled by the Latched Address/Data Control signal.

Interface Circuits

Various gates, transistors and relays perform multiplexing or level shifting functions for the multi-use pins on Copy and master sockets.

For EEPROMS a wave shaper circuit centred around IC37 conditions the rise and fall times of Vpp.

Relays 2 and 3 each 4 pole change over contacts switch the pin 20's of the Copy sockets between Output Enable function or Vpp (Intel 2732, 2732A and Mostek MK2764).

Pin 1 of Master Socket & Copy Socket 1 have extra circuitry to permit reading & programming of the 27512 device.

Display and Piezo Sounder

IC45 latches selection of Code B or Hex display formats on the Display and also drives the piezo sounder which is situated on PSU board.

The 8 digit L.E.D. display is driven by IC44 a multiplexed display driver with internal RAM. IC42 latches the digit blanking (which is not available from IC44 with Hex display format). IC40,41 gate digit blanking to Common Cathode drive transistors Q48 to Q55. The L.E.D. display consists of two 4 digit 7 segment Litronix DL4770 displays.

Keyboard

IC43 inputs the eight push button switches onto the data bus when Port 10 is inputed.

Intelligent Identifier

Relay 5 and associated components permit intelligent interrogation of Eproms by switching Address 9 to +12v in accordance with Intel Specification. Earlier versions of Eproms do not have this facility and may be destroyed by this action. Software will be incorporated at a latter date to make full use of Intelligent Interrogation when manufacturers produce suitable Eproms.

Power Supply

Mains Transformer

A toroidal mains transformer of the following specification is used in 'E' Series programmers :-

Input	Colour Code	Outputs	Colour Code
: 0v	: Blue	: 0v	: Red +
: 110v	: Violet	: 8v 5Amps:	: Red
: 120v	: White	:	:
:	:	: 0v	: Orange +
: 0v	: Black	: 24v 2Amps:	: Orange
: 110v	: Grey	:	:
: 120v	: Brown	:	:
: Screen	: Green/Yellow	:	:

General

A conventional circuit with two separate transformer windings providing the +5v supply and the Vpp supply (+25v, +21v and +12.5v). Series regulators are used to regulate the supply to the required voltages. The 'common' connection on the regulators have switched pull down resistors to select different voltage outputs. IC5 has six open collector drivers which interface TTL levels from the port control to the switching levels required by the power supply components.

A Monostable IC6 detects half-cycles of the mains supply giving advance warning (RAM PROTECTION Signal) in the event of power failure.

LED indicators monitor the main +5v logic supply and Vpp output.

+5v Supplies

IC3 supplies the +5v supply to the logic on the main board.
IC7 supplies the +5v supply to the logic on the Interface and memory board.
IC4 provides +5v or +6v to the EPROM sockets switched on or off by Q8.
Preset potententionmeters provide fine trimming of output voltages.

Vpp Supplies

IC2 supplies the main Vpp power designated ZZ. IC5 gates C & D select +12.5v or 21v or 25v output voltage. Q13, 14 provide current limiting at 500mA.

A separate supply switched through Q4 provides Vpp power for pin's 22 of the EPROMs (2732 or 27512 devices only). Q4 provides +12v only for the erasure of EEPROM devices.

P.S.U. Monitor

Two quad voltage comparitors IC47, 48 are used to check the switched +5v level, 12.5v, 21v and 24v. IC49,50 output this data on to the data bus when PORT 11 or 12 is inputed.

IC46 is a precision voltage reference for the comparitors and its' output is set to 2.90v.

Interface and Memory Board

This board has four functions:-

1. Hex-Keypad
2. Serial RS232 Input/Output
3. Parallel Input/Output
4. Random Access Memory

1. Hex-Keypad

IC23 an LSI Keyboard decoder chip enables the reading of the 16 hex keys and 4 function keys.

2. Serial RS232 Input/Output

The heart of the Serial I/O is the 6402 U.A.R.T. IC27. IC25 an eight bit latch holds the baud rate selection (bits 0,1,2,3) and the remaining bits are used to control parity, stop bits and clear the DATA READY flag. IC26 is a four bit latch used to select 7 or 8 data bits and handshaking output flags. IC24 generates a 2.4576 MHz master clock and converts this to the required U.A.R.T. clocking speed set by IC25. IC29 converts the CMOS signal levels to RS232 levels (approx +- 9v). Conversely IC19 converts the RS232 input levels to CMOS levels. The CTS and DSR handshaking inputs are buffered through IC28.

IC30 converts the +12v supply to -9v to provide the negative bias on the RS232 Output lines.

3. Parallel Input/Output

IC1 a Z80A PIO chip provides two 8 bit parallel I/O ports at T.T.L. levels with handshaking control.

4. Random Access Memory

IC2 an 8203 DRAM controller provides all the interface and control for 128K x 8 DRAM. In standard configuration eight DRAM chips (IC3 to IC10) are fitted each chip holding 64K x 1. Expansion to 128K x 8 can be achieved by plugging in eight more 64K x 1 chips (IC11 to IC18).

Selection of the eight RAM pages is made through IC26 and IC21. The three bits latched in these chips (Y0,1,2) provide the three high order addresses AD 14,15,16 selecting one of eight 16K pages. BRAM signal is the master chip enable to the whole of RAM.

A WAIT state is automatically added to the Z80A read cycle each time a RAM read is requested. One half of IC34 on the main board generates the WAIT state request from the BRAM signal.

ADDRESS SECTOR DECODER

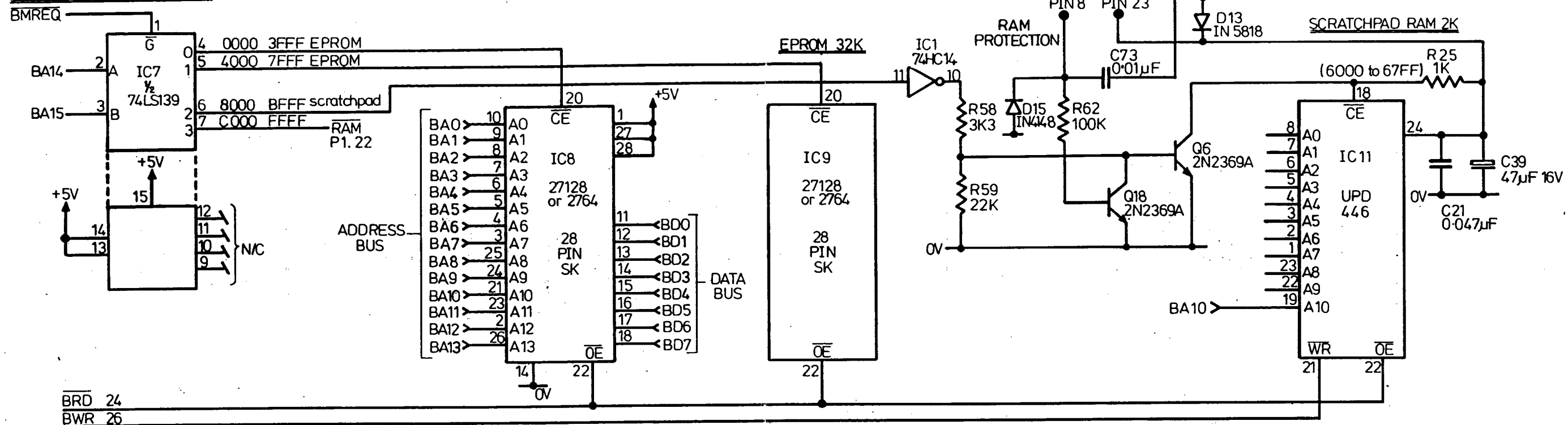

BRD 24
BWR 26

CLOCK CIRCUIT

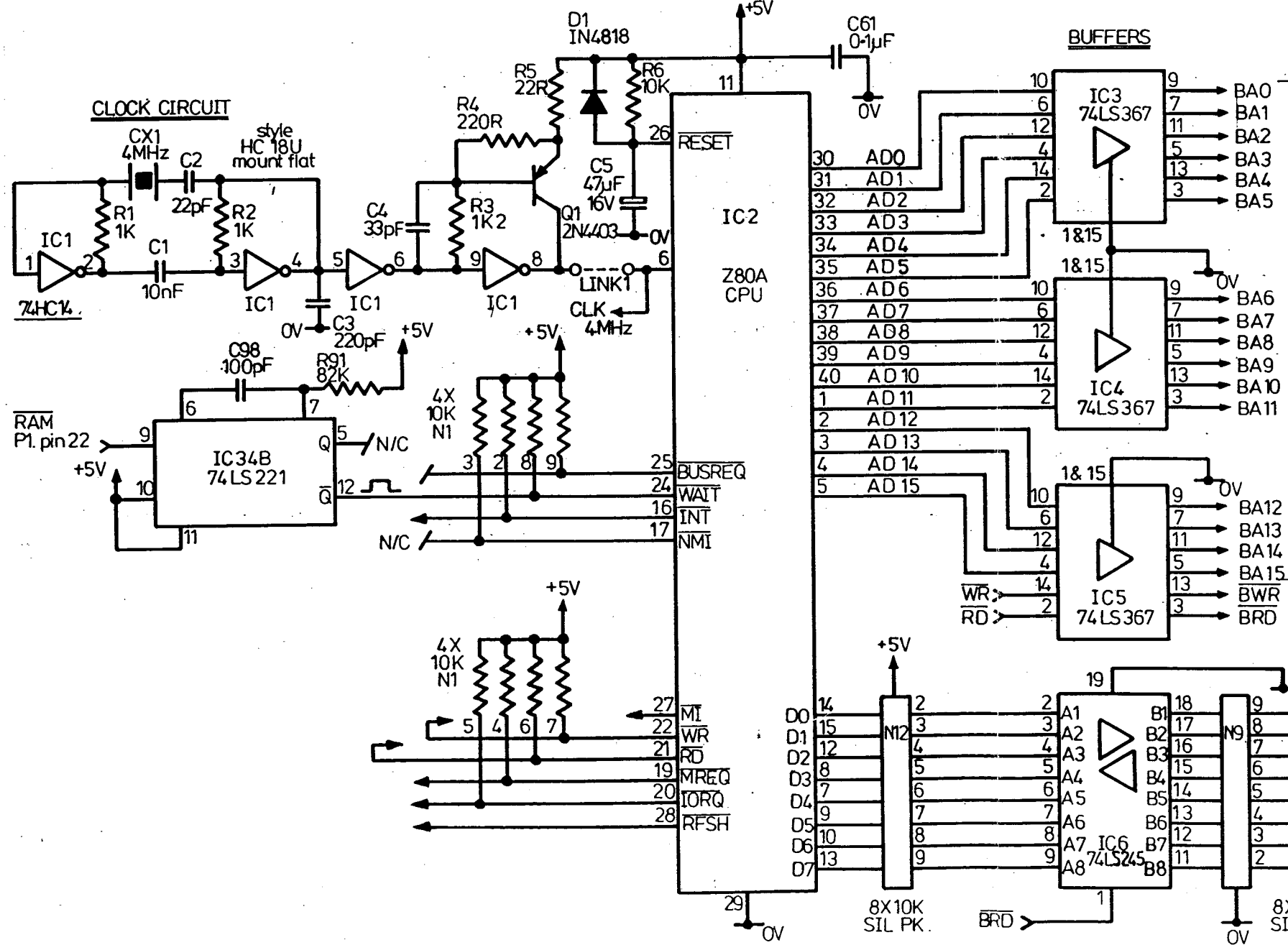

BUFFERS

P2 34 WAY CONN.

P1 50 PIN CONNECTOR

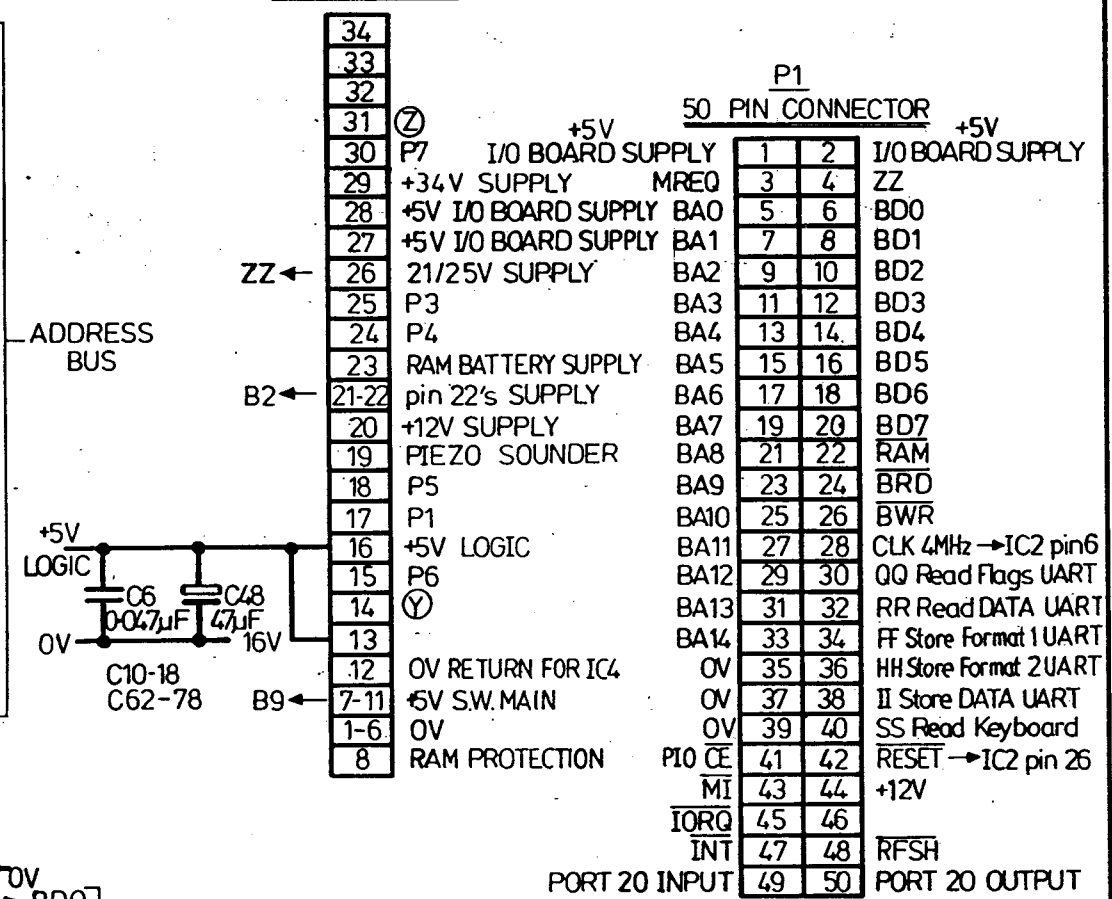

E/B SERIES PROGRAMMER CIRCUIT			
C.P.U. CIRCUIT			
DRAWN	<i>[Signature]</i>	ELAN DIGITAL SYSTEMS LTD.	
ISSUE	4		
DRG N°	326/1		

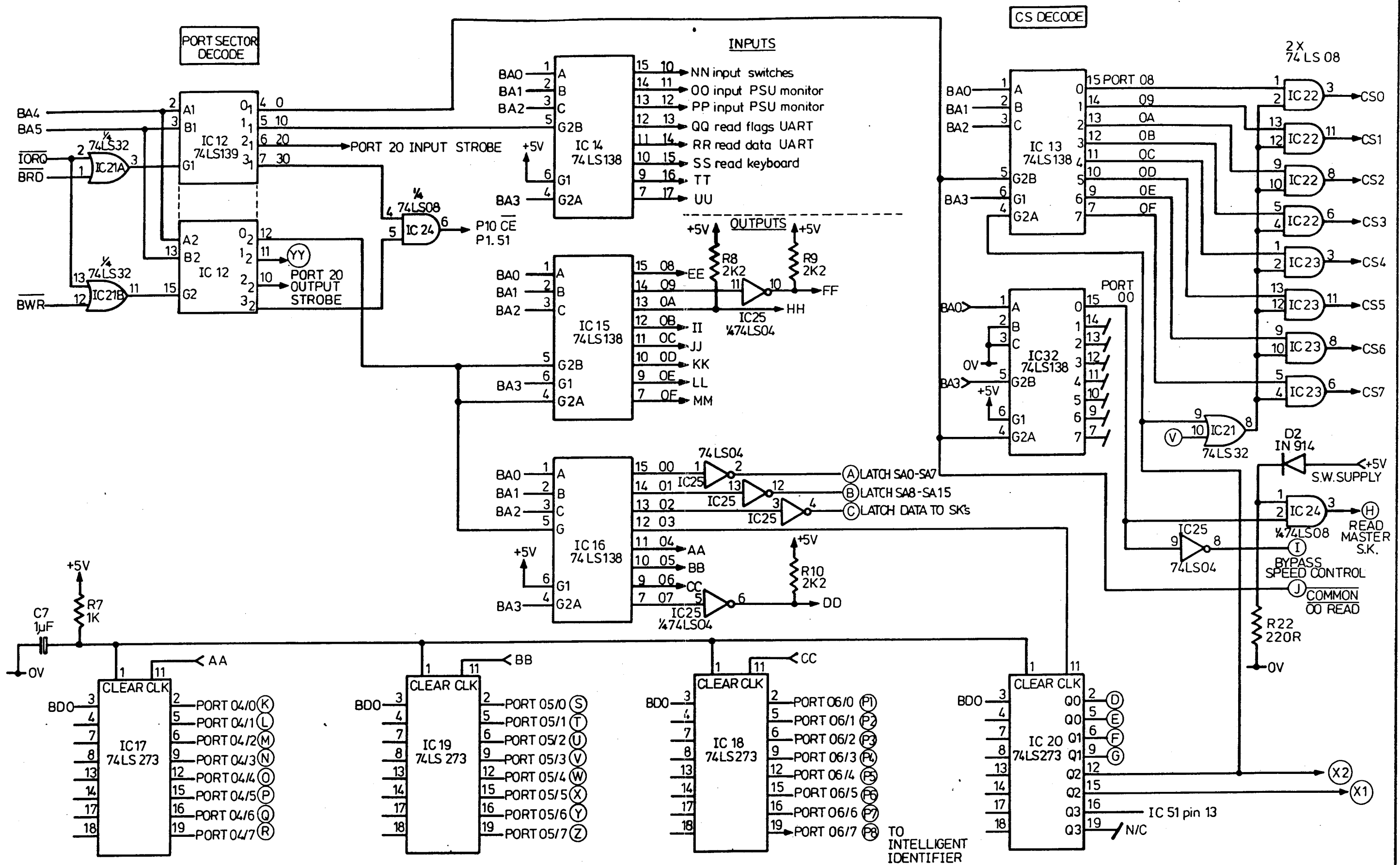

OUTPUT PORT LATCHES

E/B SERIES PROGRAMMER CIRCUIT

PORT & CS DECODE CIRCUITS

DRAWN	<i>[Signature]</i>	ELAN DIGITAL SYSTEMS LTD.
ISSUE	2	
DRG N°	326/2	

E² V_{pp} WAVE SHAPER

LEVEL SHIFTERS / SWITCHING CIRCUITRY

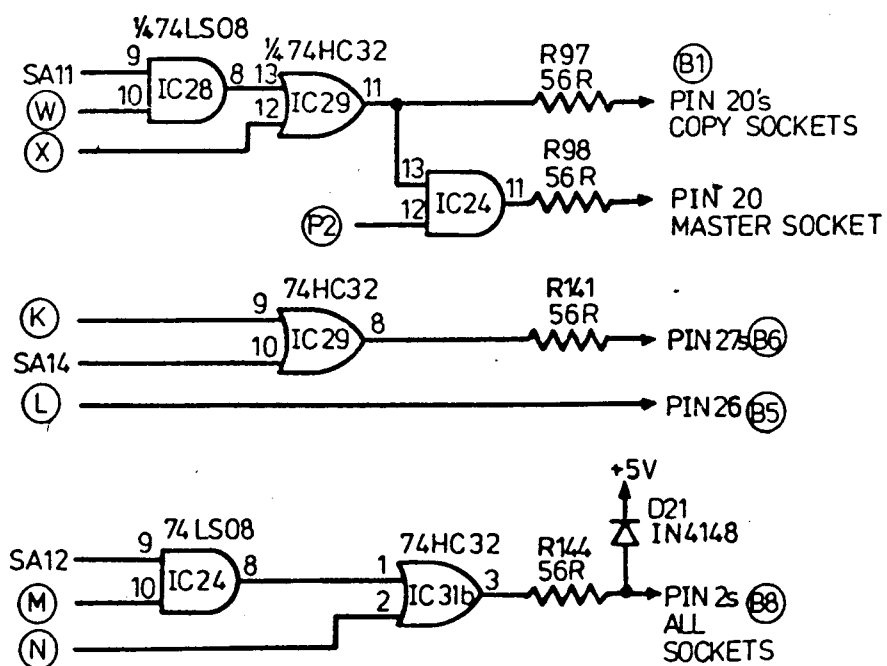
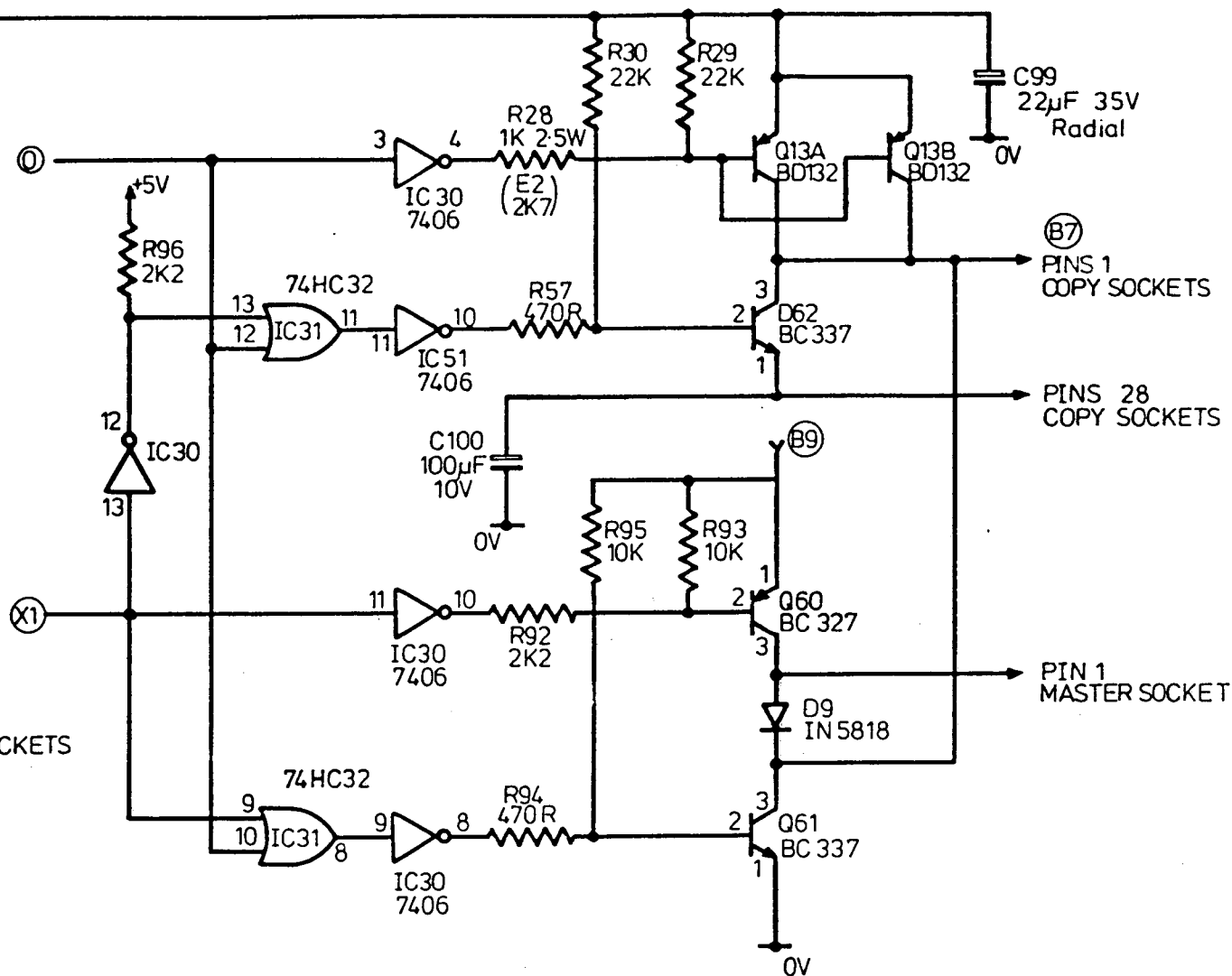
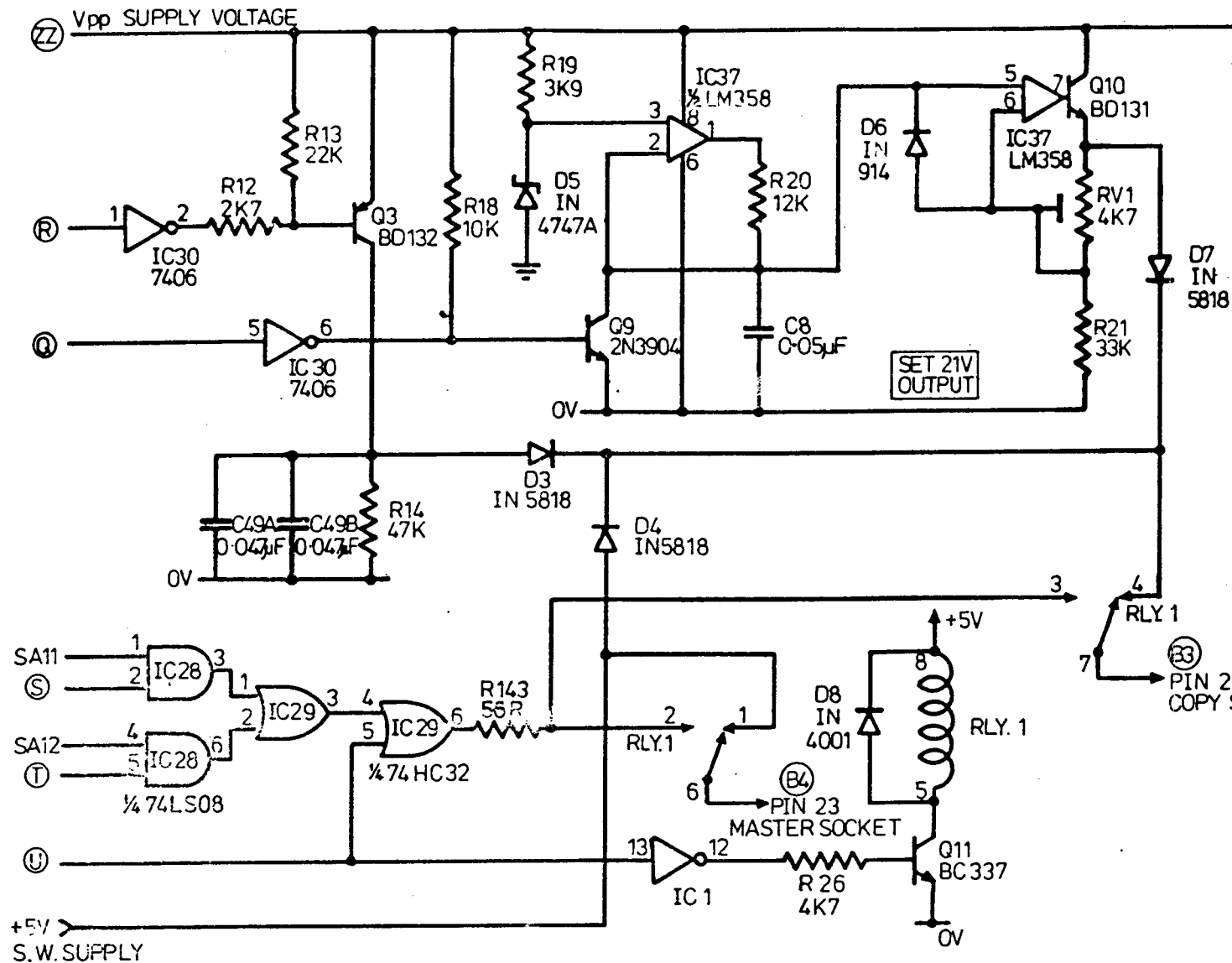

E/B SERIES PROGRAMMER CIRCUIT

LEVEL SHIFTING CIRCUITS

DRAWN	<i>ELAN</i>	ELAN DIGITAL	
ISSUE	1	SYSTEMS LTD	
DRG N°	326/3a		

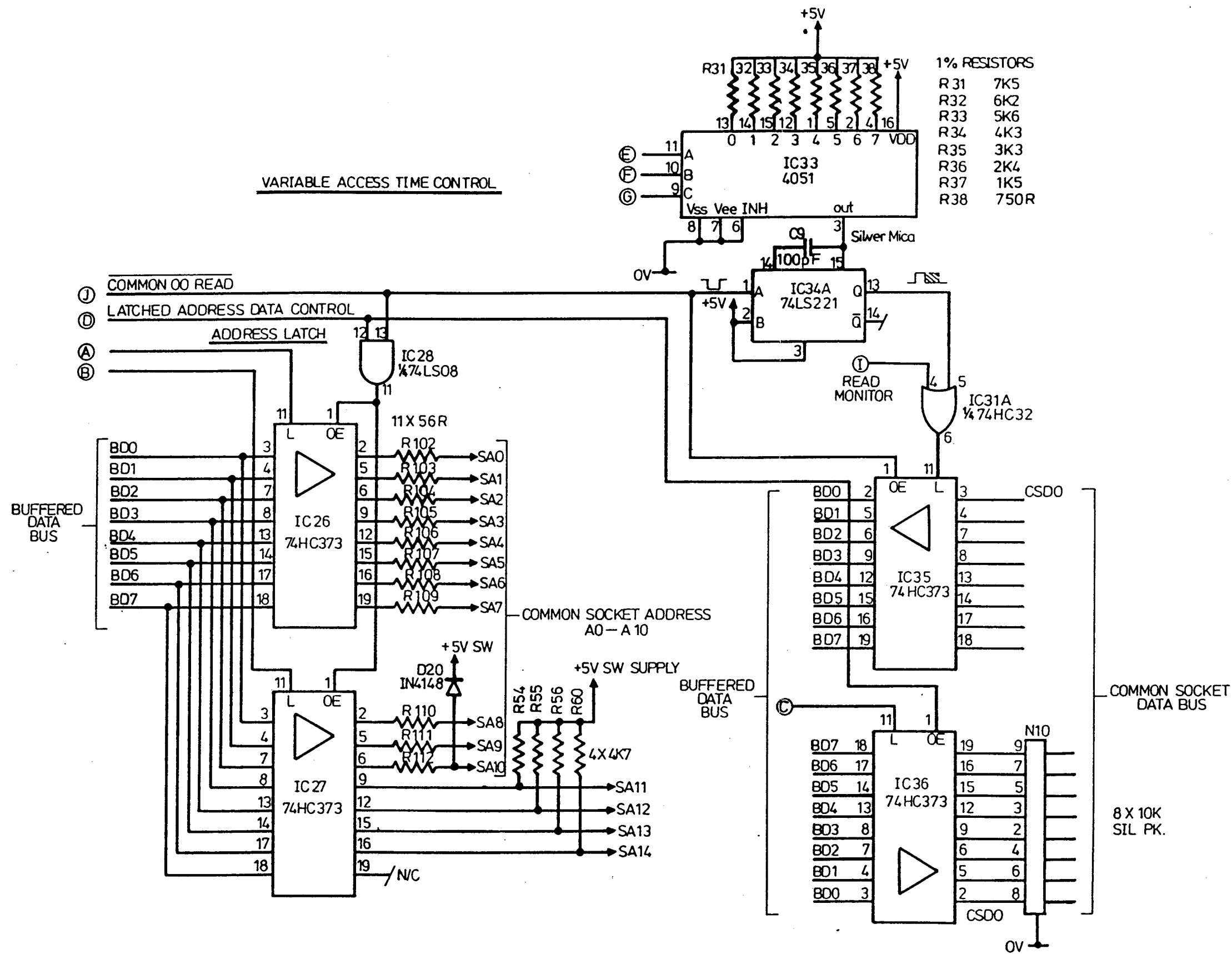

- 1% RESISTORS
- R 31 7K5
 - R 32 6K2
 - R 33 5K6
 - R 34 4K3
 - R 35 3K3
 - R 36 2K4
 - R 37 1K5
 - R 38 750R

E/B SERIES PROGRAMMER CIRCUIT			
ADDRESS LATCH & DYNAMIC ACCESS			
DRAWN	<i>APB</i>	ELAN DIGITAL	
ISSUE	1	SYSTEMS LTD	
DRG N°	326/3b		

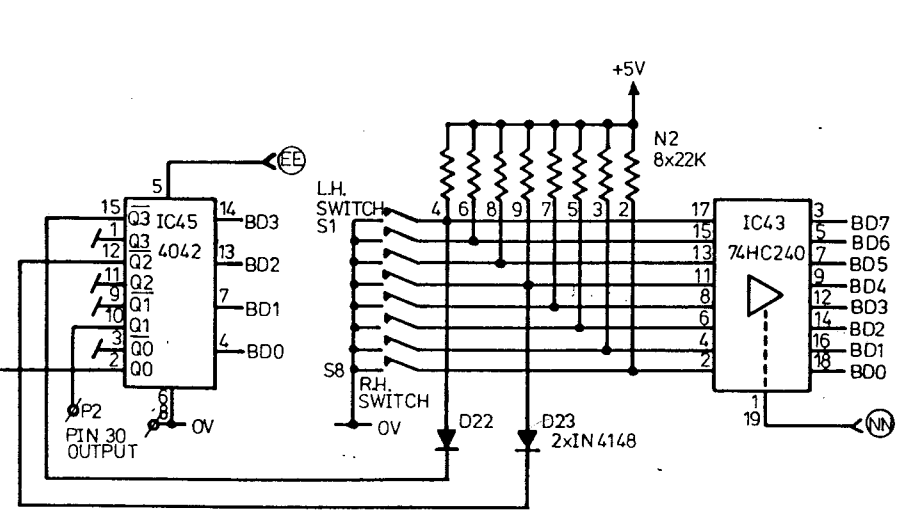
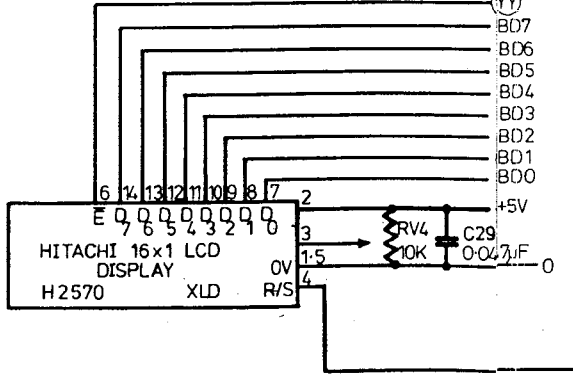
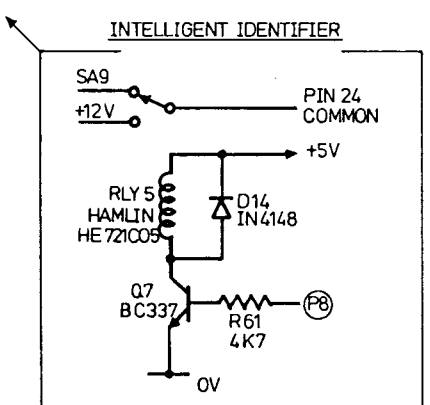
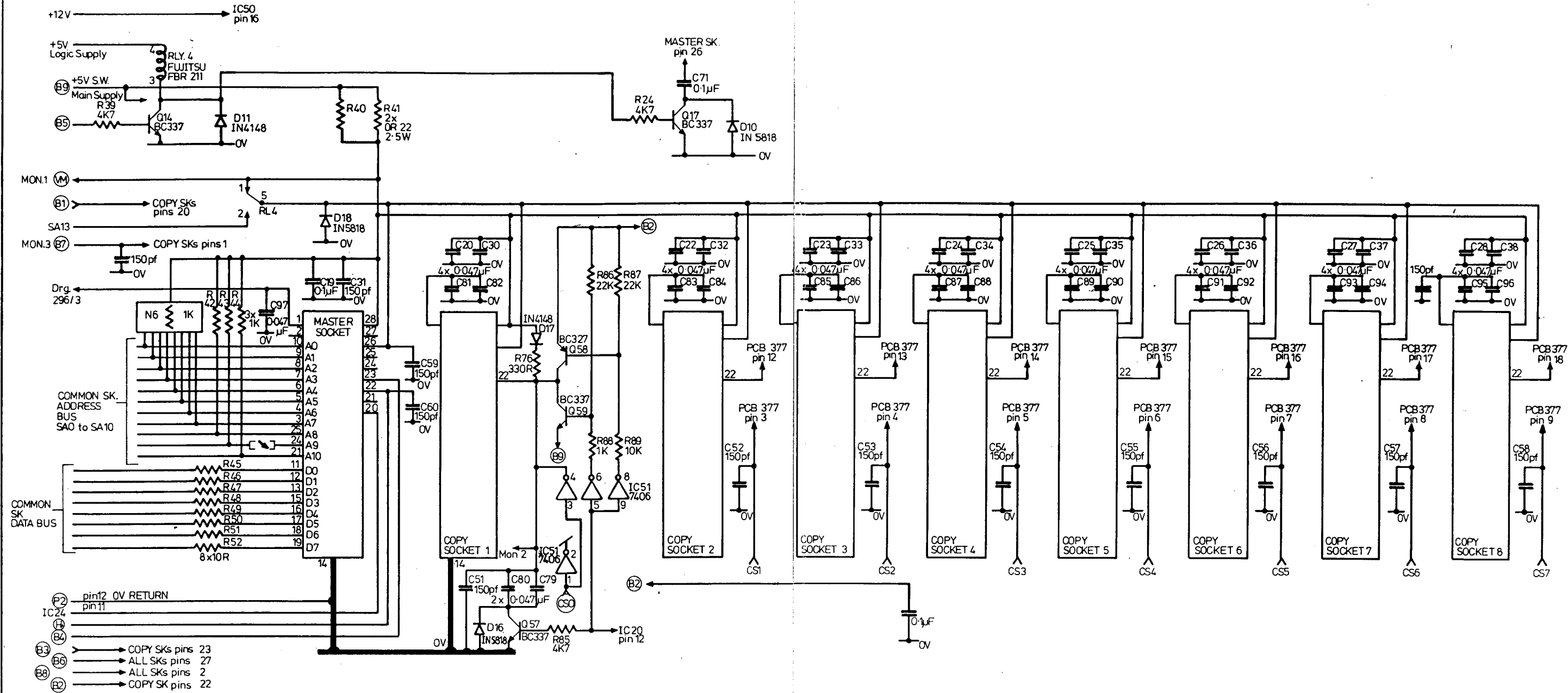

E/B SERIES PROGRAMMER CIRCUITS			
MASTER/COPY SKT & DISPLAY CIRCUITS			
DRAWN	<i>[Signature]</i>	ELAN DIGITAL	
ISSUE	3	SYSTEMS LTD	
DRG N°	326/4		

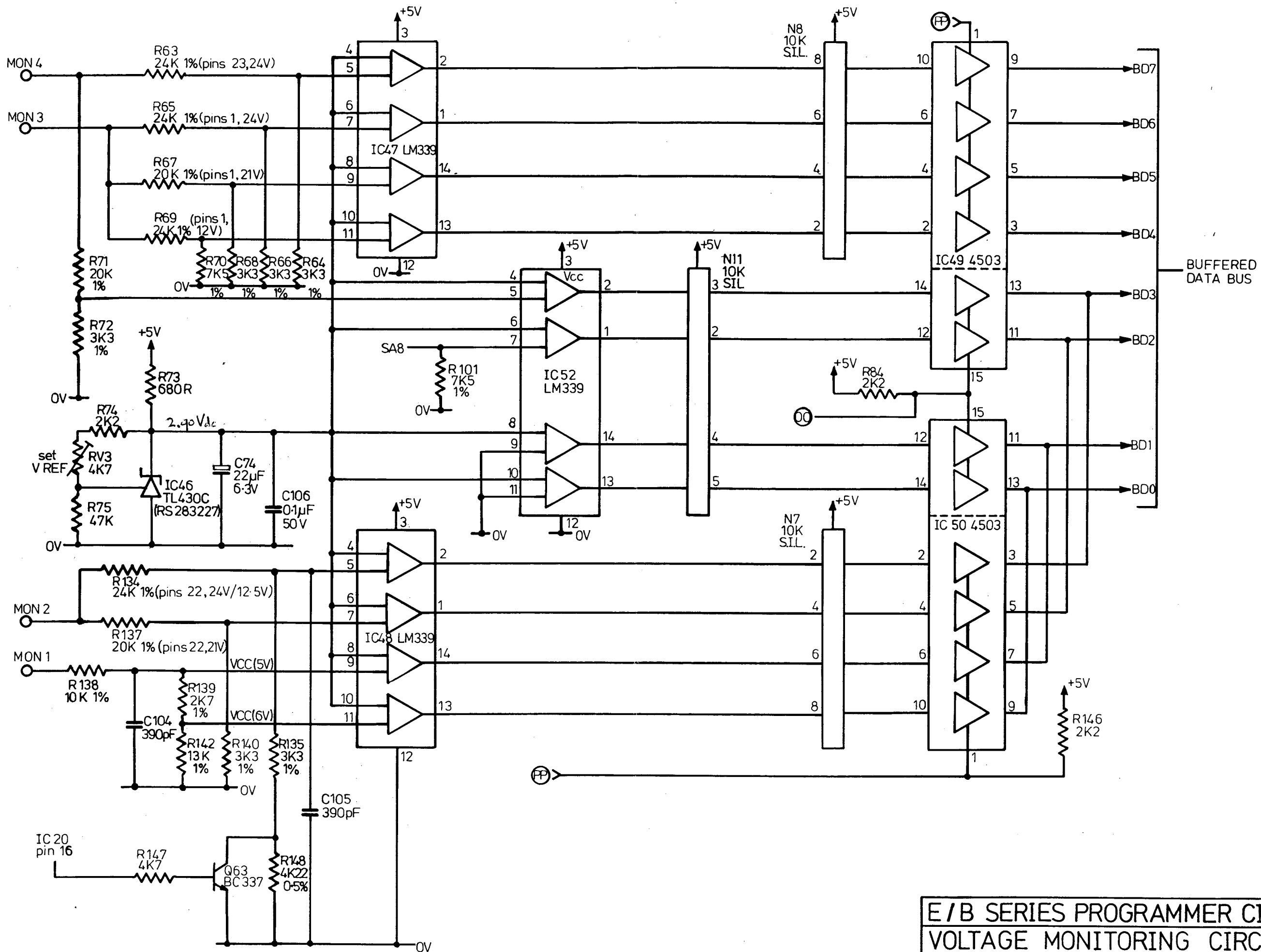

E / B SERIES PROGRAMMER CIRCUIT		
VOLTAGE MONITORING CIRCUIT		
DRAWN	<i>RJD</i>	ELAN DIGITAL SYSTEMS LTD.
ISSUE	5	
DRG N°	326/5	

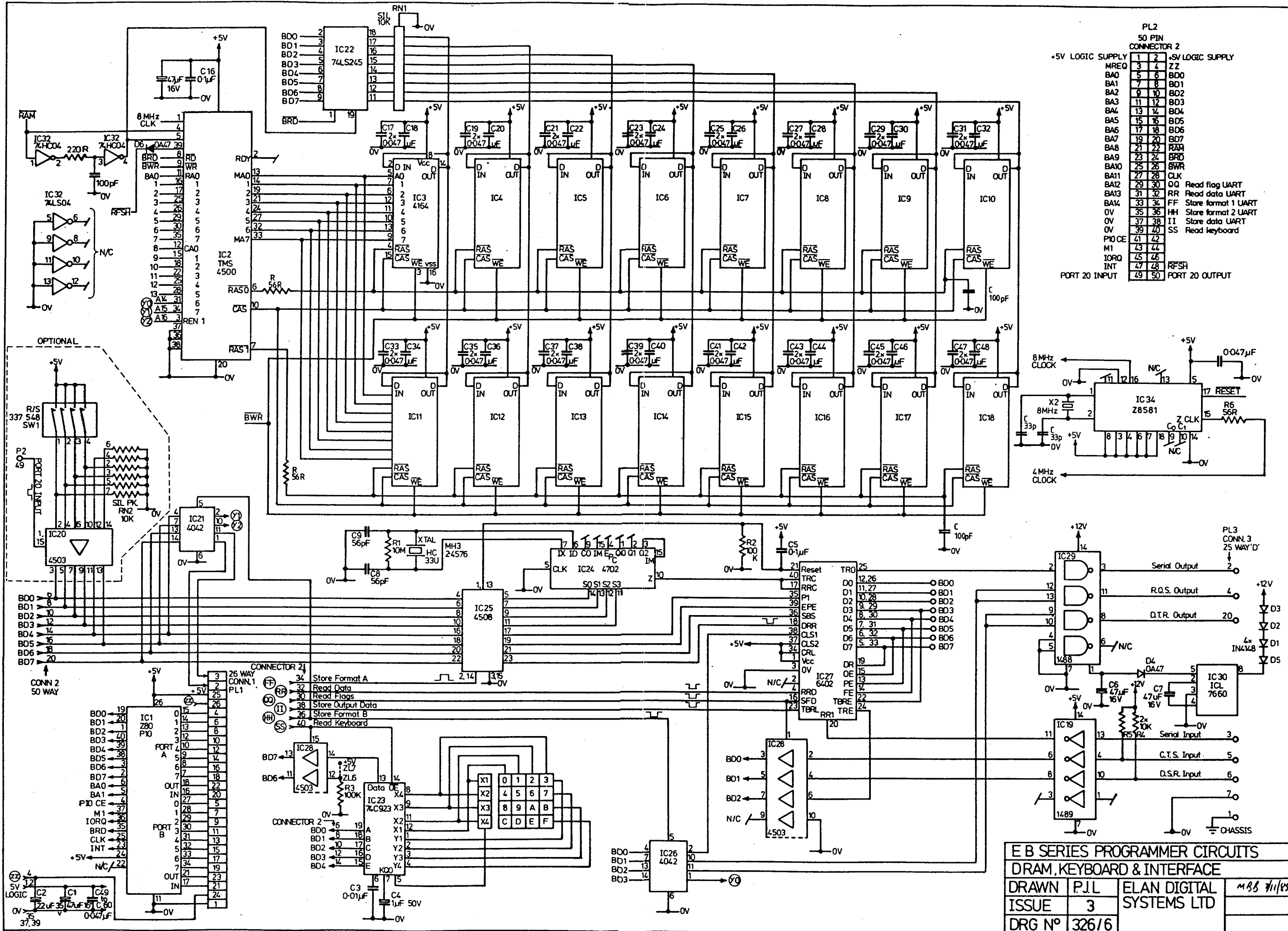

PL2
50 PIN
CONNECTOR 2

+5V LOGIC SUPPLY	1	2	+5V LOGIC SUPPLY
MREQ	3	4	ZZ
BA0	5	6	BD0
BA1	7	8	BD1
BA2	9	10	BD2
BA3	11	12	BD3
BA4	13	14	BD4
BA5	15	16	BD5
BA6	17	18	BD6
BA7	19	20	BD7
BA8	21	22	RAM
BA9	23	24	BRD
BA10	25	26	BWR
BA11	27	28	CLK
BA12	29	30	Read flag UART
BA13	31	32	Read data UART
BA14	33	34	Store format 1 UART
OV	35	36	HH Store format 2 UART
OV	37	38	II Store data UART
OV	39	40	SS Read keyboard
P10 CE	41	42	
M1	43	44	
IORQ	45	46	
INT	47	48	RFSH
	49	50	PORT 20 OUTPUT

E B SERIES PROGRAMMER CIRCUITS
DRAM, KEYBOARD & INTERFACE

DRAWN	P.J.L	ELAN DIGITAL	M.B.S 7/11/85
ISSUE	3	SYSTEMS LTD	
DRG N°	326/6		

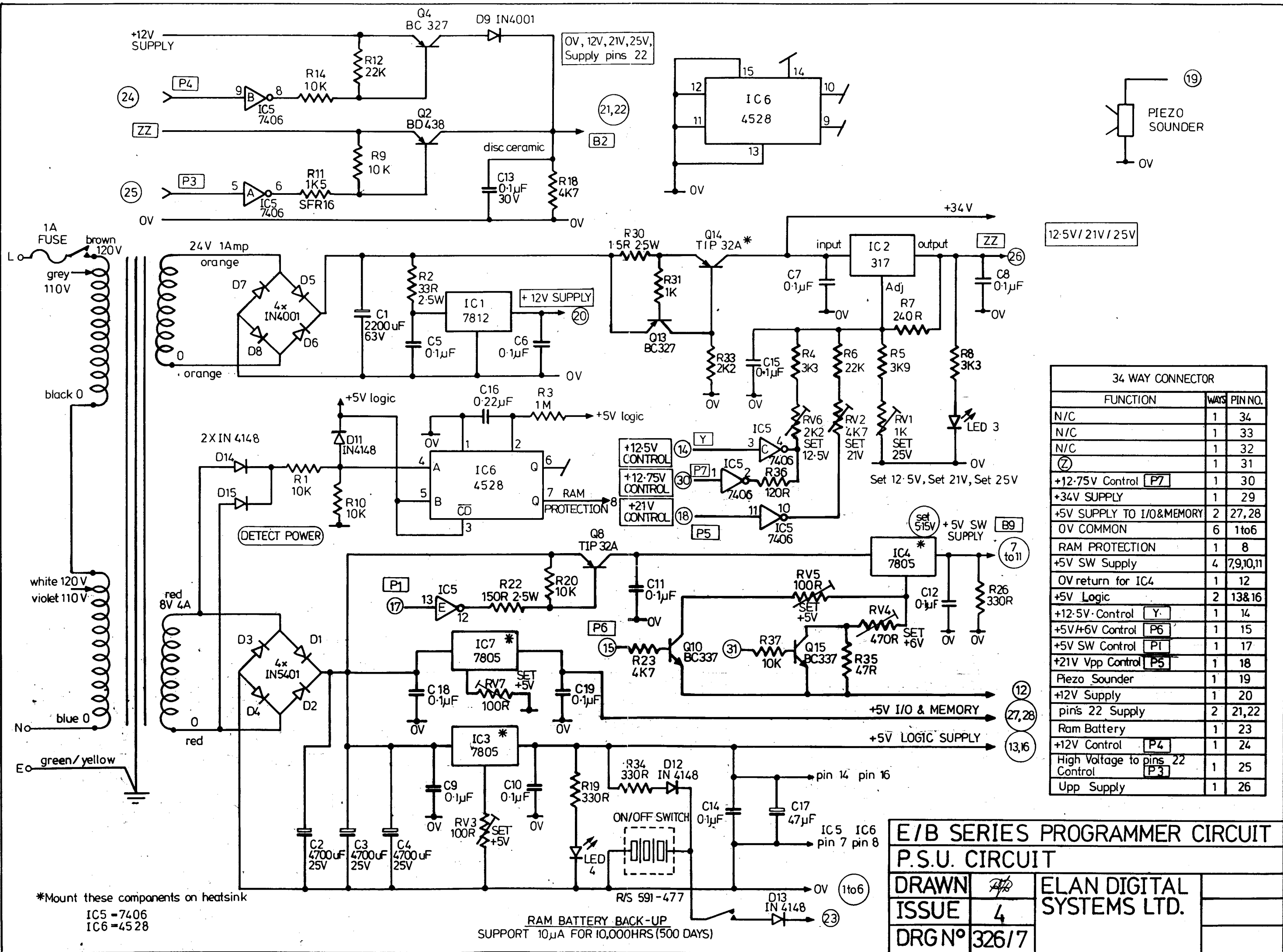

12.5V/21V/25V

34 WAY CONNECTOR		
FUNCTION	WAYS	PIN NO.
N/C	1	34
N/C	1	33
N/C	1	32
(Z)	1	31
+12.75V Control [P7]	1	30
+34V SUPPLY	1	29
+5V SUPPLY TO I/O&MEMORY	2	27,28
0V COMMON	6	1to6
RAM PROTECTION	1	8
+5V SW Supply	4	7,9,10,11
0V return for IC4	1	12
+5V Logic	2	13&16
+12.5V Control [Y]	1	14
+5V/6V Control [P6]	1	15
+5V SW Control [P1]	1	17
+21V Vpp Control [P5]	1	18
Piezo Sounder	1	19
+12V Supply	1	20
pins 22 Supply	2	21,22
Ram Battery	1	23
+12V Control [P4]	1	24
High Voltage to pins 22 Control [P3]	1	25
Upp Supply	1	26

*Mount these components on heatsink
 IC5 = 7406
 IC6 = 4528

RAM BATTERY BACK-UP
 SUPPORT 10µA FOR 10,000HRS (500 DAYS)

E/B SERIES PROGRAMMER CIRCUIT	
P.S.U. CIRCUIT	
DRAWN	<i>[Signature]</i>
ISSUE	4
DRGN°	326/7
ELAN DIGITAL SYSTEMS LTD.	

